

Mazda 626 MX-6

1995
Wiring Diagram

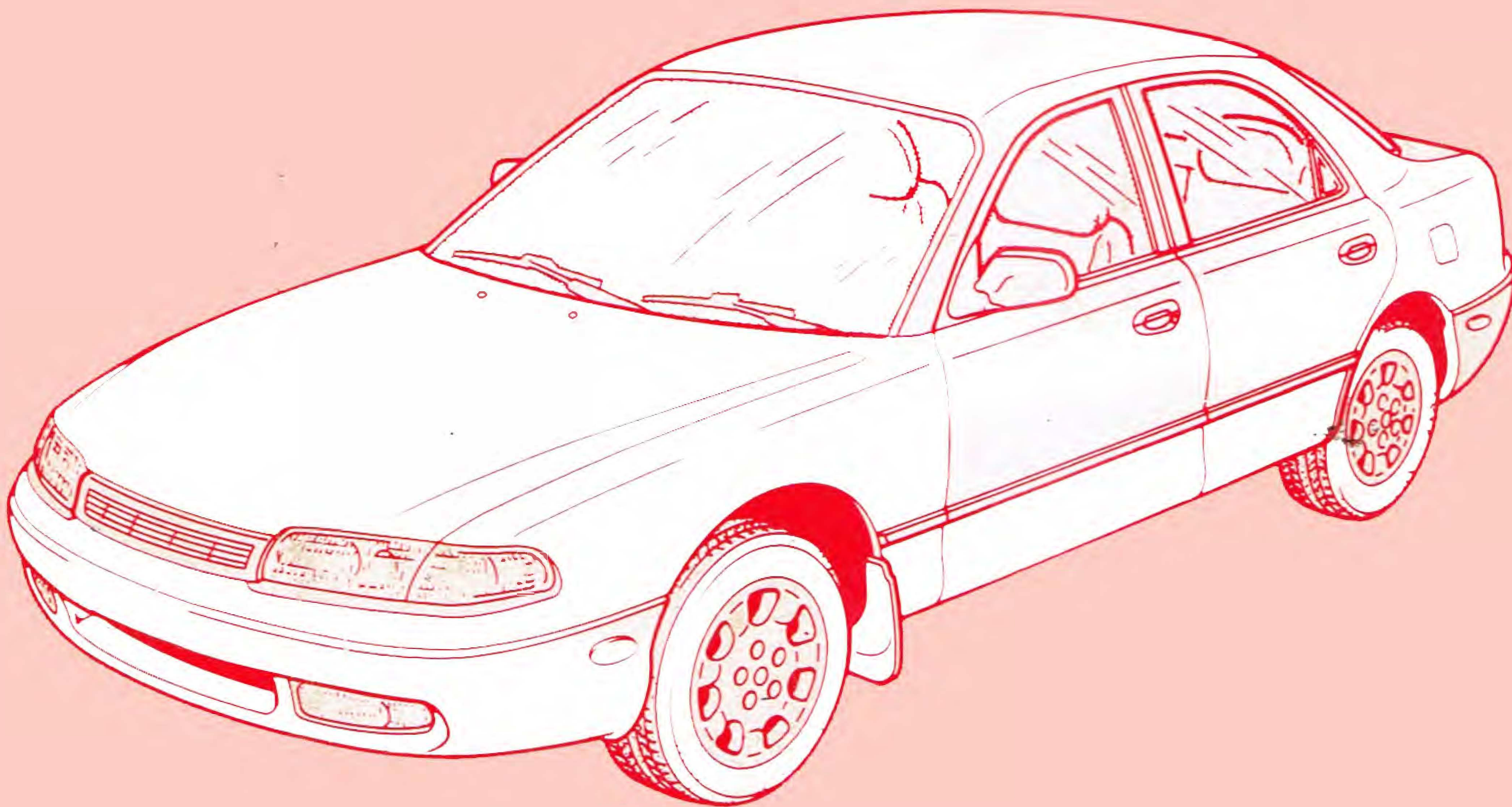

mazda

SYSTEM INDEX

ENGINE RELATED SYSTEMS

STARTING SYSTEM	
FS ATX	Z-28
FS MTX	Z-30
KL ATX	Z-32
KL MTX	Z-34
CHARGING SYSTEM	Z-36
ENGINE CONTROL SYSTEM	
FS ATX	Z-38
FS MTX	Z-46
KL	Z-52
IGNITION SYSTEM	
FS ATX	Z-38
FS MTX	Z-46
KL	Z-52
FUEL CONTROL SYSTEM	
FS	Z-60
KL	Z-62
COOLANT FAN SYSTEM	
FS	Z-64
KL	Z-66

CHASSIS RELATED SYSTEMS

EC-AT CONTROL SYSTEM	
FS	Z-38
KL	Z-108
SHIFT-LOCK SYSTEM	Z-112
ANTILOCK BRAKE SYSTEM	Z-150

INSTRUMENT CLUSTER-RELATED SYSTEMS

INSTRUMENT CLUSTER	Z-68
--------------------------	------

BODY-RELATED SYSTEMS

WINDSHIELD WIPER AND WASHER	Z-74
HORNS	Z-98
REAR WINDOW DEFROSTER	
626	Z-122
MX-6	Z-124
POWER WINDOWS	
626	Z-130
MX-6	Z-132
POWER DOOR LOCKS	
626	Z-134
MX-6	Z-136
POWER DOOR LOCKS (WITH KEYLESS ENTRY SYSTEM)	
626	Z-138
MX-6	Z-140
POWER OUTSIDE MIRRORS	
626	Z-142
MX-6	Z-144
SLIDING SUNROOF	
626	Z-146
MX-6	Z-148
POWER SEAT	Z-154
CRUISE CONTROL SYSTEM	
EXCEPT FS ATX	Z-156
FS ATX	Z-158
AIR BAG SYSTEM	Z-162
CENTRAL PROCESSING SYSTEM	Z-164
THEFT-DETERRENT SYSTEM	Z-164

INTERIOR LIGHTING SYSTEMS

GLOVE COMPARTMENT LIGHT	Z-114
ILLUMINATION LIGHTS	Z-114
COURTESY LIGHTS	
626	Z-118
MX-6	Z-120
IGNITION KEY ILLUMINATION	
626	Z-118
MX-6	Z-120
INTERIOR LIGHT	
626	Z-118
MX-6	Z-120
SPOT LIGHTS	
626	Z-118
MX-6	Z-120
VANITY MIRROR LIGHTS	Z-118
TRUNK COMPARTMENT LIGHT	
626	Z-122
MX-6	Z-124

EXTERIOR LIGHTING SYSTEMS

HEADLIGHTS	
FEDERAL AND CALIFORNIA 626	Z-76
FEDERAL AND CALIFORNIA MX-6	Z-78
CANADA 626	Z-80
CANADA MX-6	Z-82
FRONT FOG LIGHTS	
KL	Z-84
DAYTIME RUNNING LIGHT(DRL)	
CANADA	Z-86
LICENCE PLATE LIGHTS	
626	Z-88
MX-6	Z-90
PARKING LIGHTS	
626	Z-88
MX-6	Z-90
FRONT SIDE MARKER LIGHTS	
626	Z-88
MX-6	Z-90
REAR SIDE MARKER LIGHTS	
626	Z-88
MX-6	Z-90
TAILLIGHTS	
626	Z-88
MX-6	Z-90
TURN AND HAZARD WARNING LIGHTS	Z-92
BACK-UP LIGHTS	
626	Z-94
MX-6	Z-96
BRAKE LIGHTS	Z-98
HIGH MOUNT BRAKE LIGHT	Z-98

AIR CONDITIONING-RELATED SYSTEMS

HEATER AND AIR CONDITIONER	Z-100
CONDENSER FAN SYSTEM	
FS	Z-104
KL	Z-106

ACCESSORIES

CIGARETTE LIGHTER	
626	Z-122
MX-6	Z-124
AUDIO SYSTEM	Z-126
POWER ANTENNA	Z-128

OTHER

DATA LINK CONNECTOR	
FS	Z-168
KL	Z-170

1995 Mazda 626, MX-6

Wiring diagram

FOREWORD

This wiring diagram incorporates the wiring schematics of the basic vehicle and available optional equipment. Actual vehicle wiring may vary slightly depending on optional equipment or local specifications, or both. All information in this booklet is based on information available at the time of printing. Mazda Motor Corporation reserves the right to make changes without previous notice.

Mazda Motor Corporation
HIROSHIMA, JAPAN

APPLICATION:

This manual is applicable to vehicles beginning with the Vehicle Identification Numbers(VIN) shown on the following page.

Z

CONTENTS

GENERAL INFORMATION	GI
GROUND POINTS	Y
ELECTRICAL WIRING SCHEMATIC	W
SYSTEM CIRCUIT DIAGRAM/ CONNECTOR LOCATIONS	A~U
COMMON CONNECTORS	X
JOINT BOX COMPLETE WIRING SYSTEM	JB
INDEX	PI

VEHICLE IDENTIFICATION NUMBERS(VIN) (CHASSIS NUMBER)

626

IYV GE22C ※S5 300001~

IYV GE22D ※S5 300001~

IYV GE12J 2 05 800001~

MX-6

IYV GE31C ※S5 300001~

IYV GE31D ※S5 300001~

WIRING COLOR CODE

Color	Code	Color	Code
Blue	L	Natural	N
Black	B	Orange	O
Brown	BR	Pink	P
Dark Blue	DL	Red	R
Dark Green	DG	Purple	PU
Green	G	Tan	T
Gray	GY	White	W
Light Blue	LB	Yellow	Y
Light Green	LG	Violet	V

GENERAL INFORMATION

Wiring Diagrams

Contents of wiring diagrams.....	GI-2
Using wiring diagrams.....	GI-2

Reading Wiring Diagrams

Ground points.....	GI-3
System circuit diagram/connector diagram	GI-4
Routing diagram	GI-6
Harness symbols.....	GI-7
Symbols	GI-8
Logic symbols	GI-10
Abbreviations used in this booklet.....	GI-10

Troubleshooting

Precautions to take when servicing an electrical system	GI-11
Handling connectors	GI-12
Using electrical measuring equipment	GI-13
Measuring voltage.....	GI-14
Measuring continuity/resistance.....	GI-15
Finding short circuits	GI-16

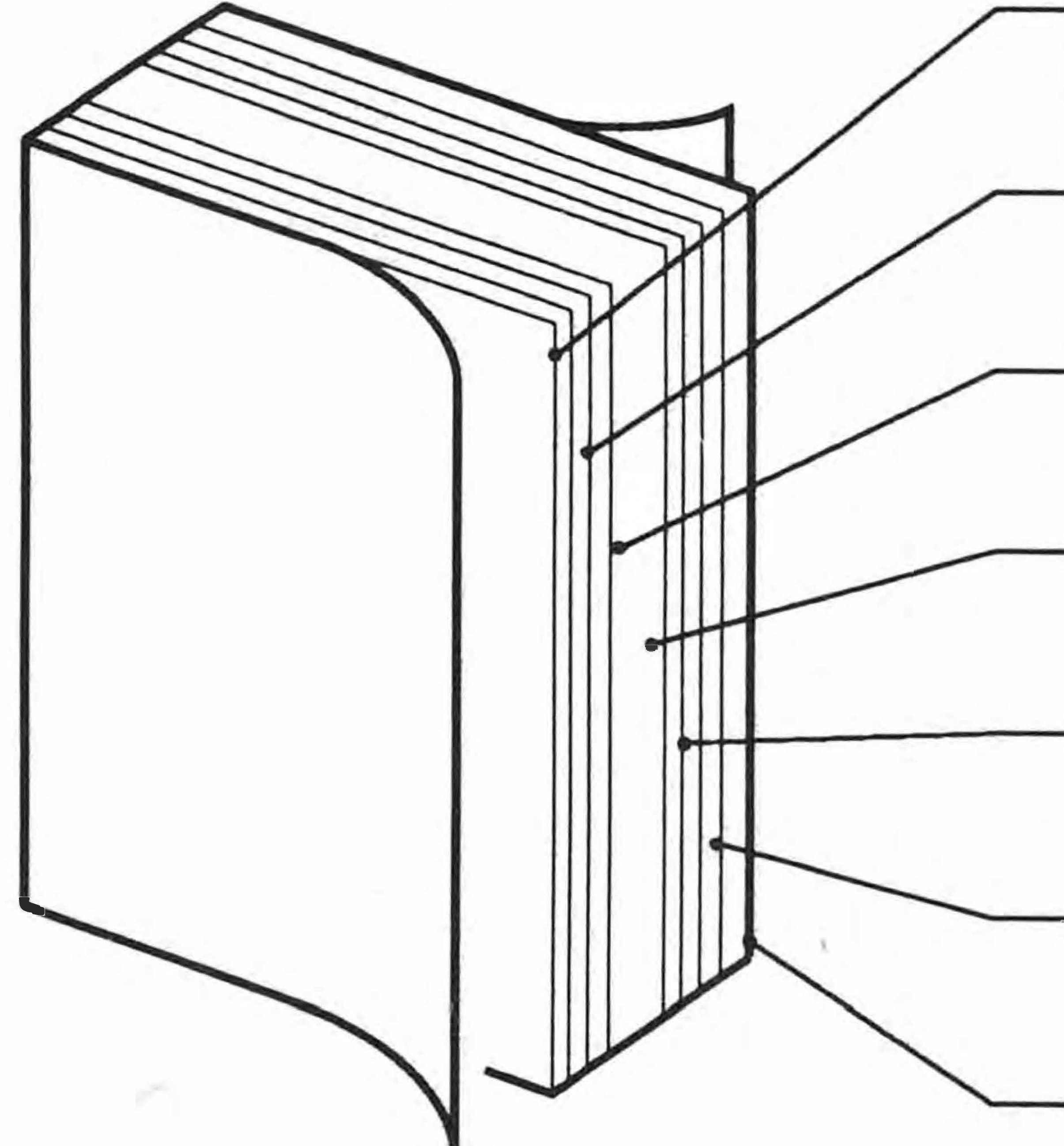

Contents of wiring diagrams

- This document comprises the 7 groups shown below. The main components are summarized in the components location diagram at the end the document.

	GI	General information	A how-to on using and reading wiring diagrams, using test equipment, checking harness and connectors, and finding trouble spots
	Y	Ground points	Ground routes from and the battery
	W	Electrical wiring schematics	Shows main fuses and other fuses for each system
	A~U	Circuit diagrams for individual systems	Shows circuit and connector diagrams and component and connector location diagrams
	X	Common connectors	Shows connectors common throughout system
	JB	Joint box complete wiring system	Shows internal circuits and connectors
	PI	Index	Gives page number of circuit diagram for each component

Using wiring diagrams

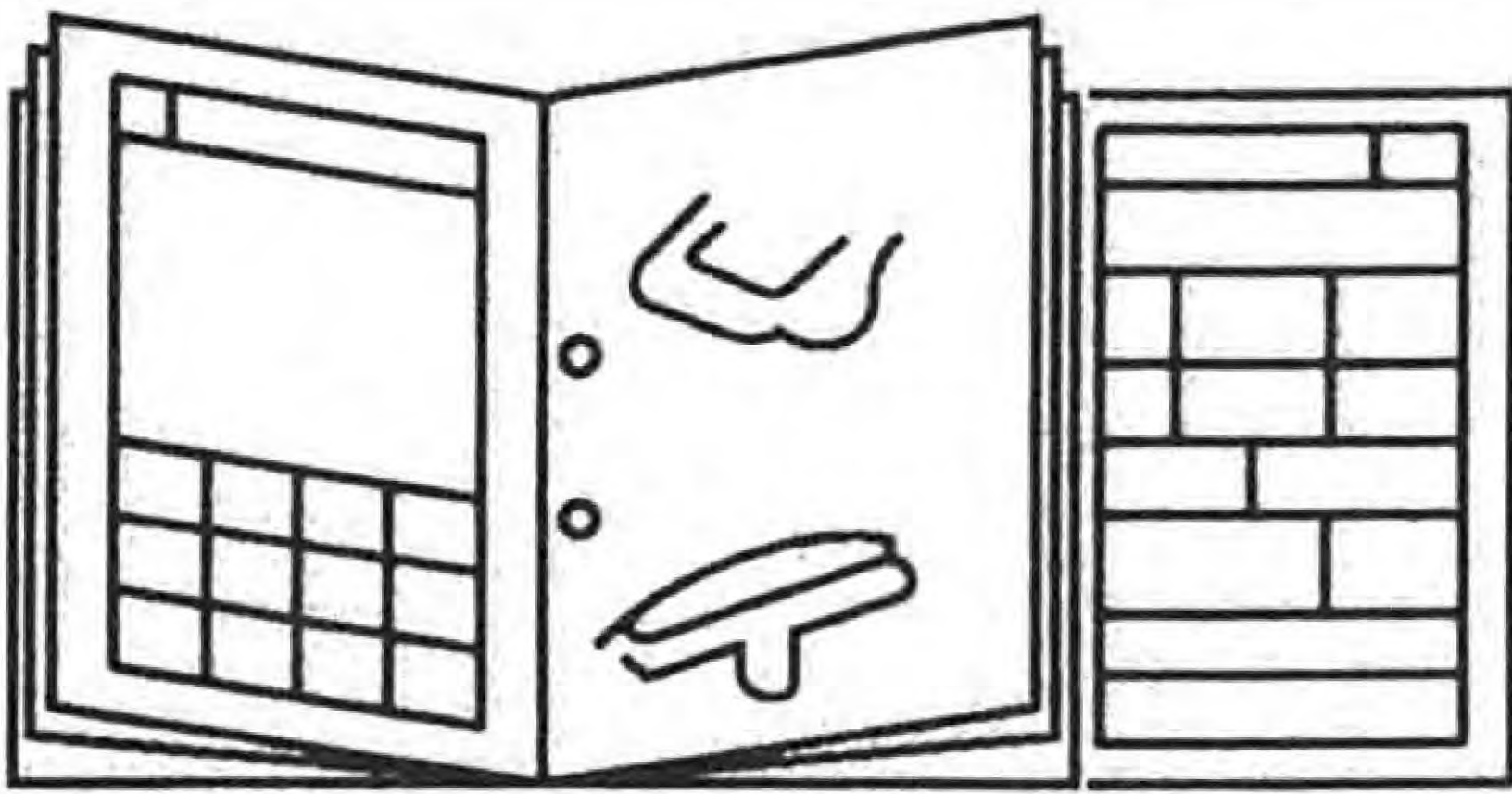
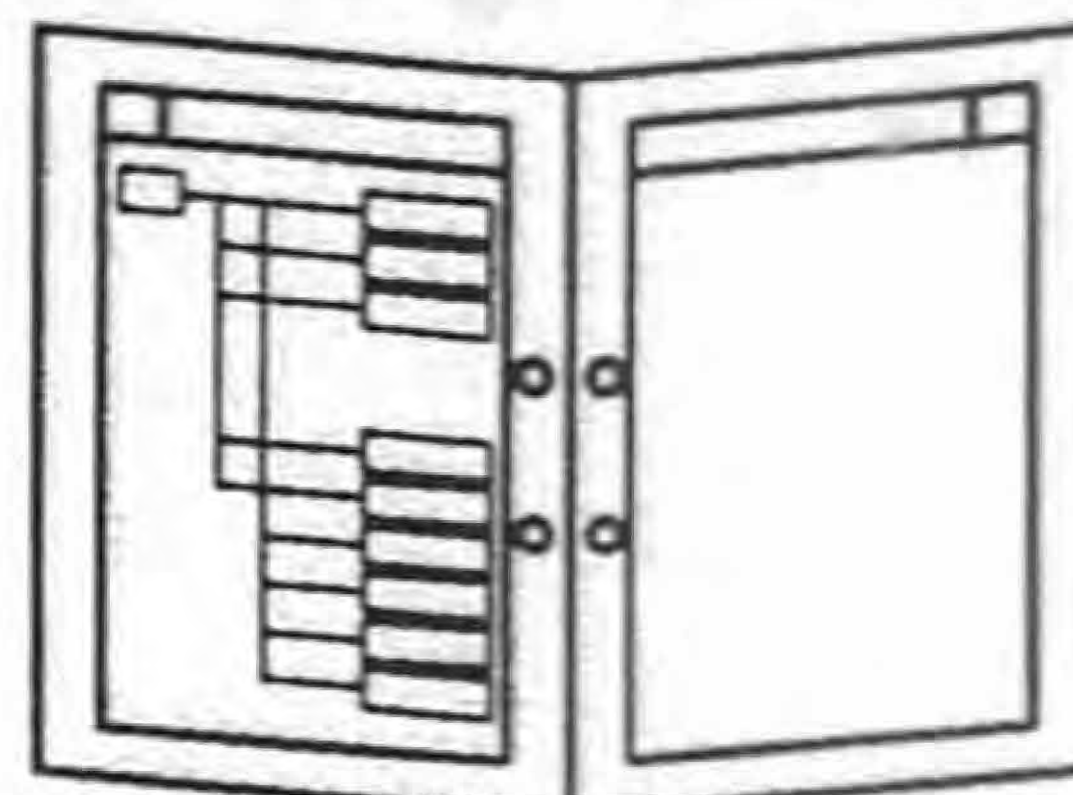
- The use of the wiring diagram depends on its application.

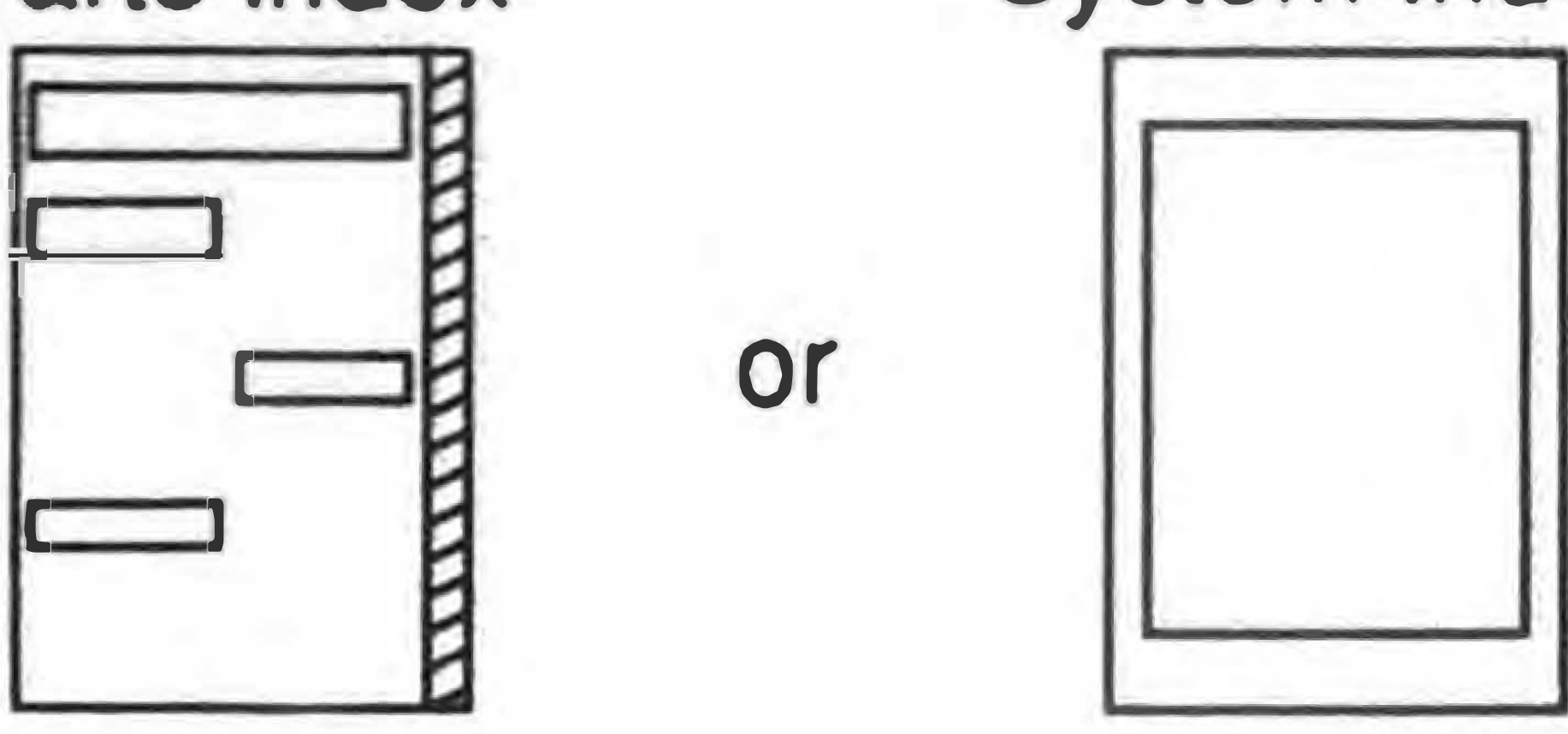
Application	Use	Application	Use
For checking circuits of individual systems	 <p>Open to page with circuit diagram and harness routing to be used and fold out common connector diagram or joint box diagram.</p>	For checking fuse connections	 <p>Open to electrical wiring schematic.</p>
For checking ground circuit of individual systems	 <p>Open to page with ground point diagram and fold out common connector diagram or joint box diagram.</p>	For finding page numbers of systems and components	<p>Parts Index System Index</p>  <p>or</p> <p>Open to parts index or system index.</p>

Ground points

- This shows ground points of the harness.

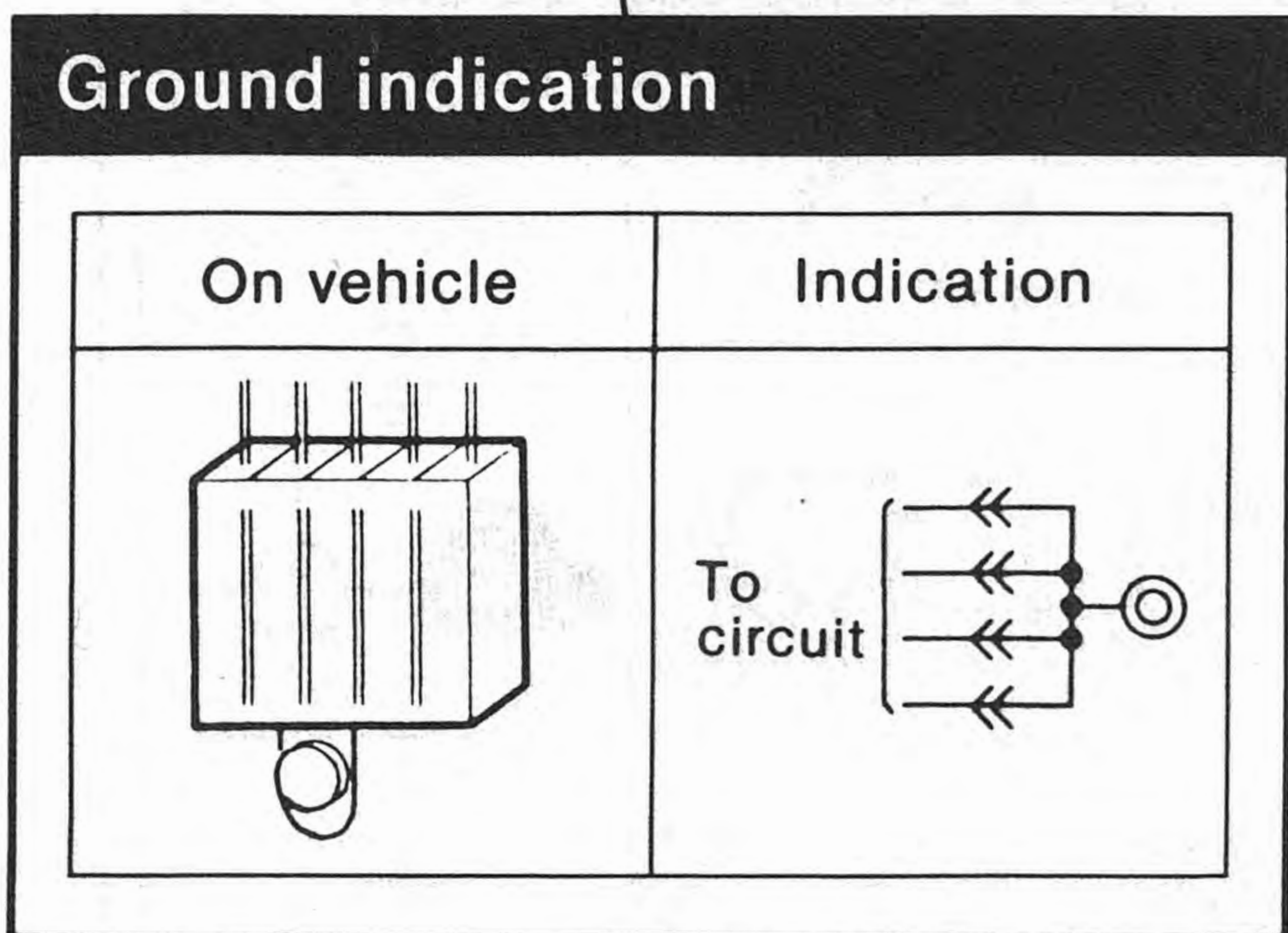
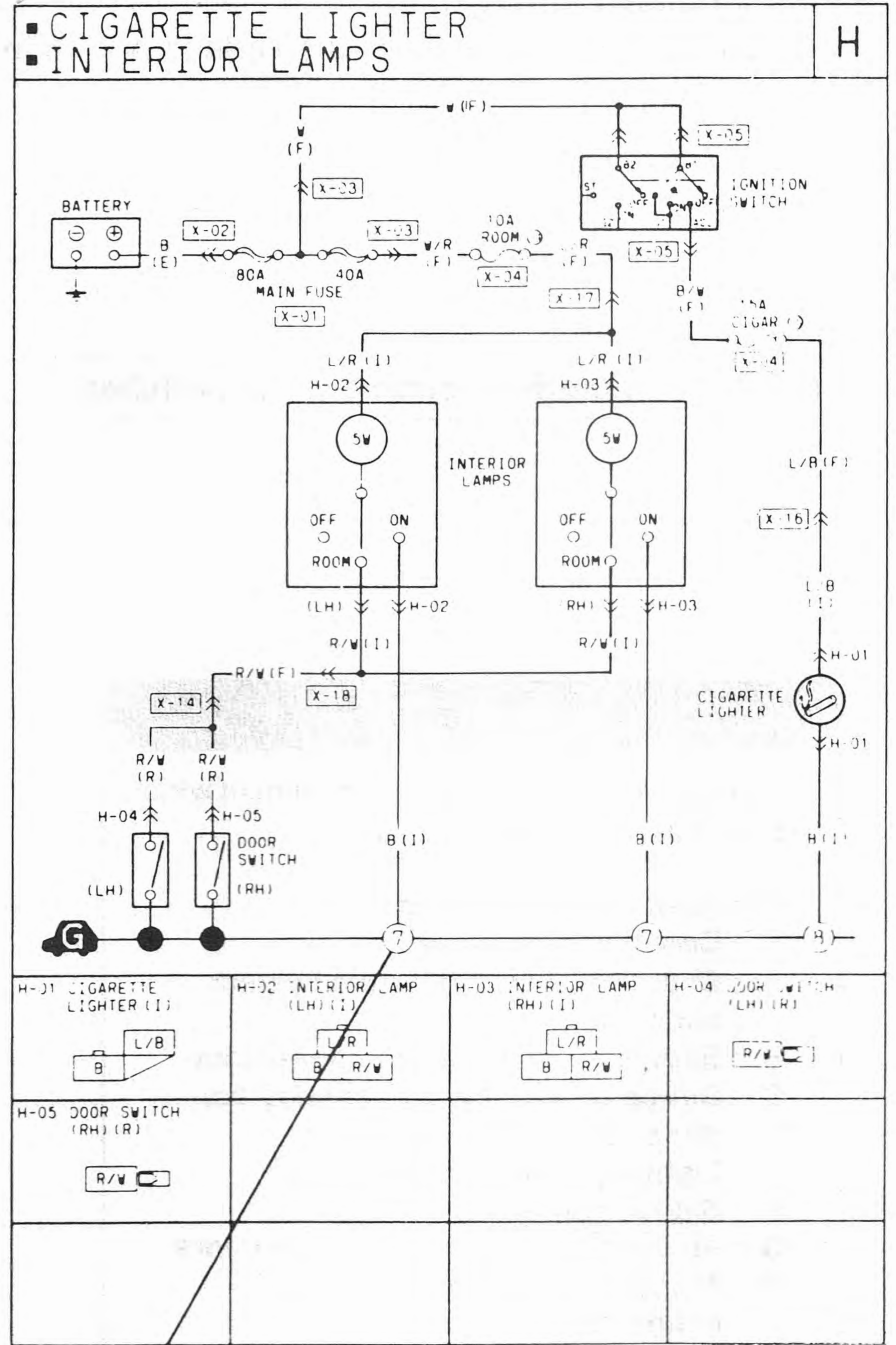
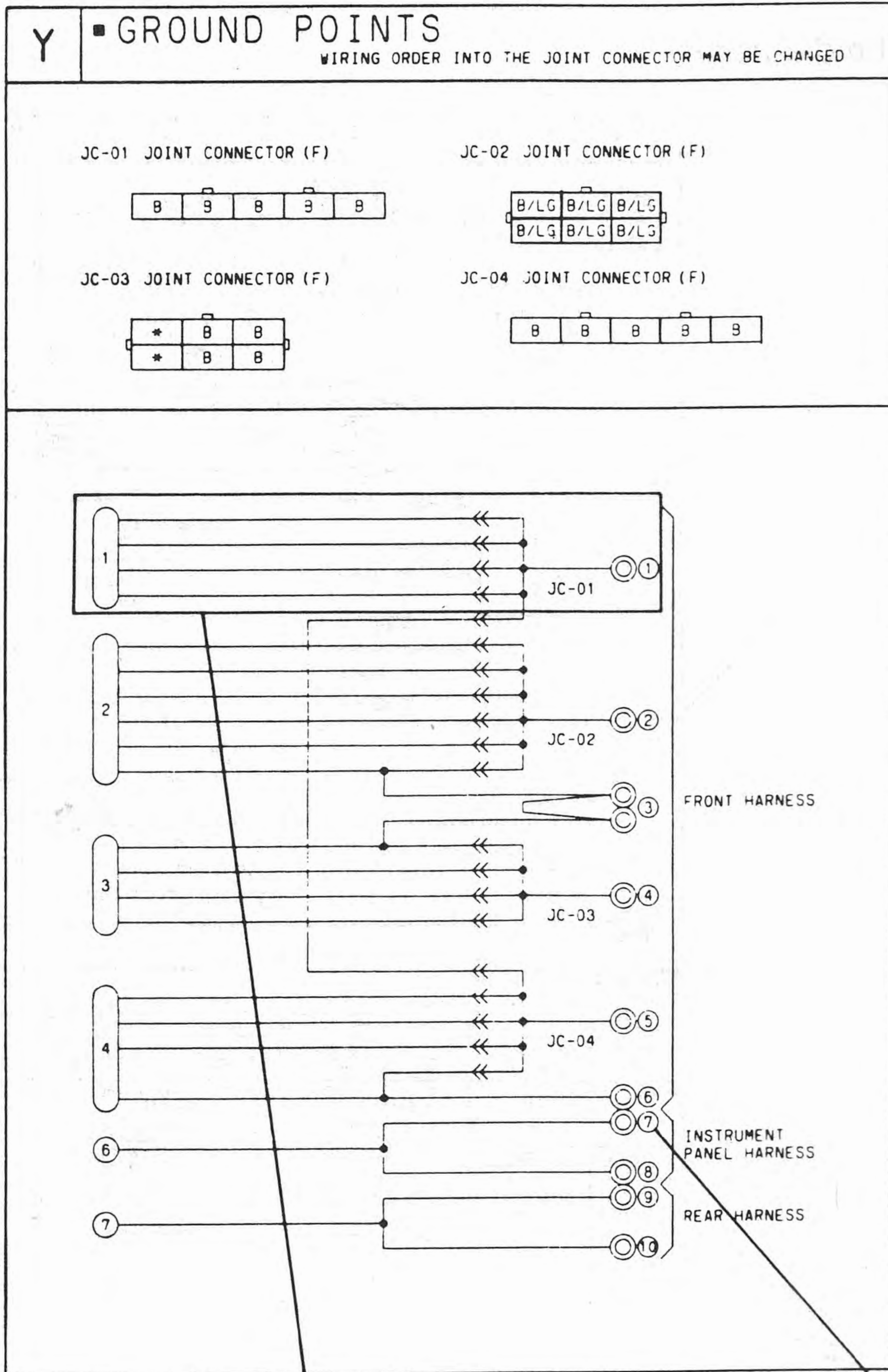

On circuit diagrams and ground points

The ground connection numbers in system circuit diagrams correspond to those in the ground point diagram.

System circuit diagram/connector diagram

- These show the circuits for each system, from the power supply to the ground. The power supply side is on the upper part of the page, the ground side on the lower part. The diagrams describe circuits with the ignition switch off.

Below is an explanation of the various points in the diagram.

Indicates operating conditions for switches.

Connector code

The prefix letter indicates the system in which the connector is used.

- JB: Joint box connections
- X : Common connectors
- A : Charging system/starting system connectors
- B : Engine control system connectors
- C : Gauge control system connectors
- D : Wiper system connectors
- E : Lighting system connectors
- F : Signal system connectors
- G : Air-conditioning system connectors
- H : Transmission control system connectors
- I : Interior lamp system connectors
- J : Audio/radio connectors
- K : Power window/power door lock system connectors
- L : Remote control mirror system connectors
- M : Sliding sunroof system connectors
- N : Power steering/4-wheel steering system connectors
- O : Anti-lock brake system connectors
- P : Power seat/seat heater system connectors
- Q : Auto cruise control system connectors
- R : Auto adjusting suspension system connectors
- S : Passive shoulder belt control/air bag system connectors
- T : Others
- Y : Ground connector

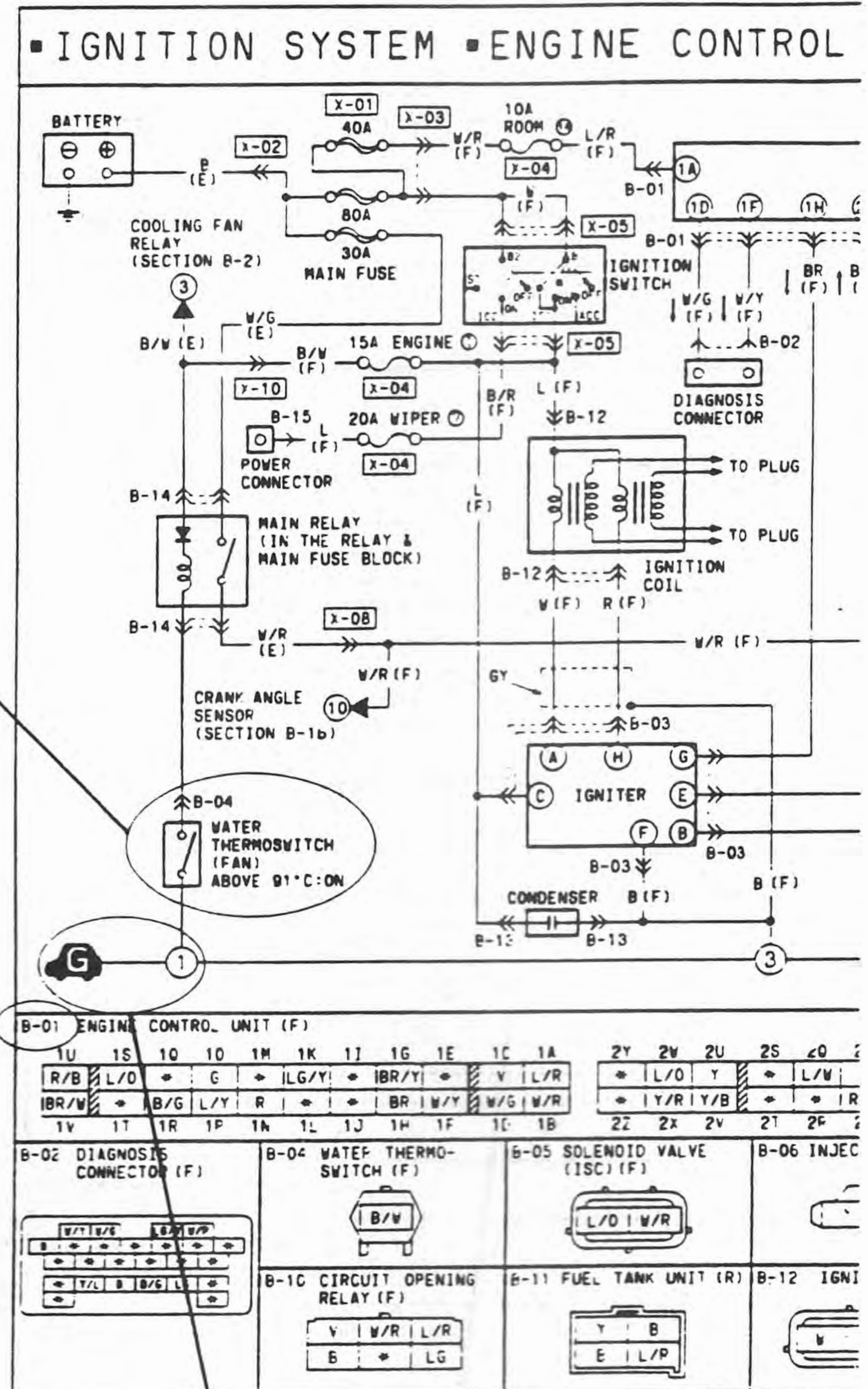

Ground numbers

A harness ground is represented differently than a unit ground.

Types of grounds	Symbol
Harness	
Unit	

The diagram also includes illustrations of a car interior showing a harness ground and an engine compartment showing a unit ground sensor.

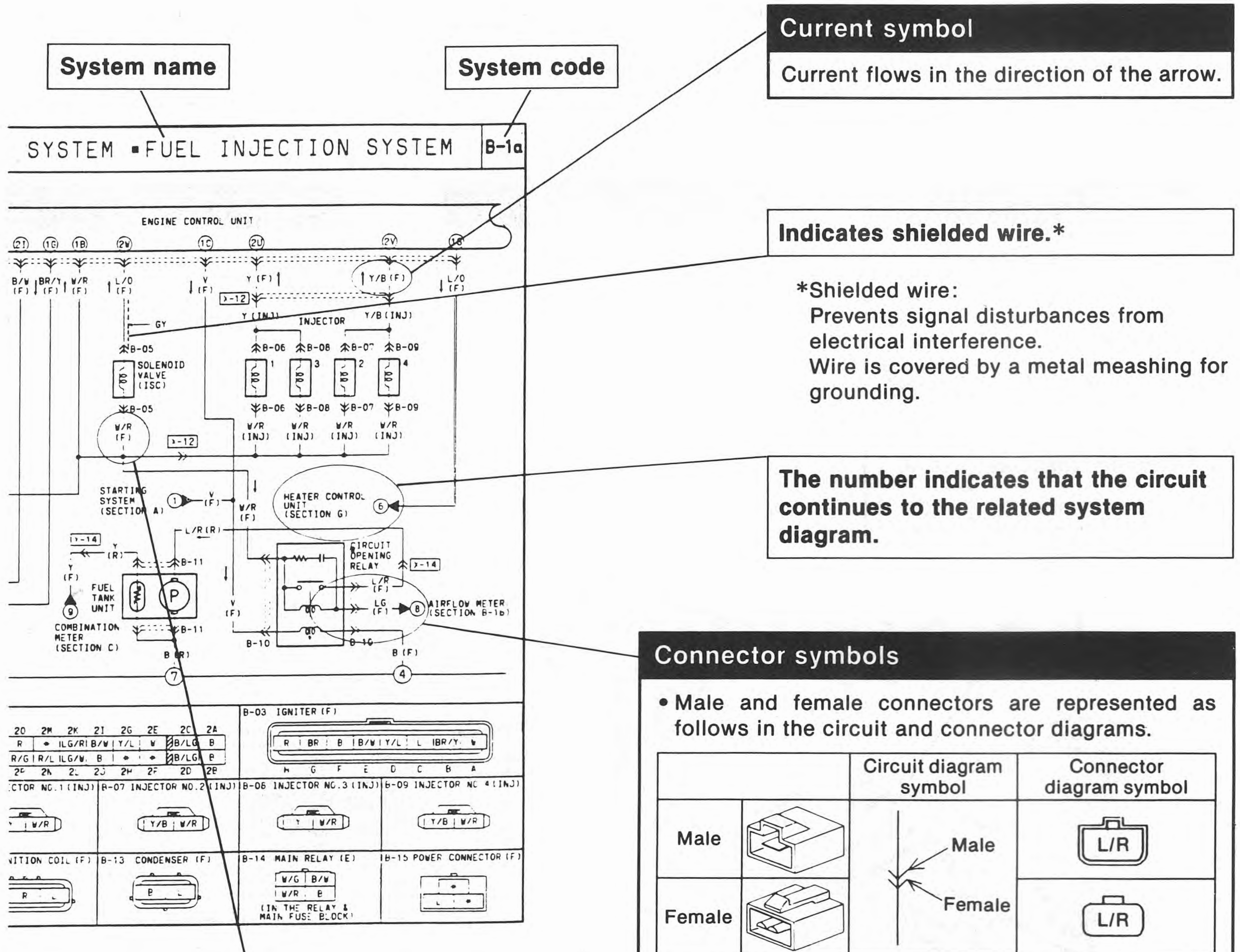

Current symbol
Current flows in the direction of the arrow.

Indicates shielded wire.*
*Shielded wire:
Prevents signal disturbances from electrical interference.
Wire is covered by a metal meshing for grounding.

The number indicates that the circuit continues to the related system diagram.

Connector symbols

• Male and female connectors are represented as follows in the circuit and connector diagrams.

	Circuit diagram symbol	Connector diagram symbol
Male		
Female		

• Like connectors are linked by dashed lines between the connector symbols.
• Connector diagrams show connectors on the harness side. The terminal indicates the view from the harness side.

(Example)

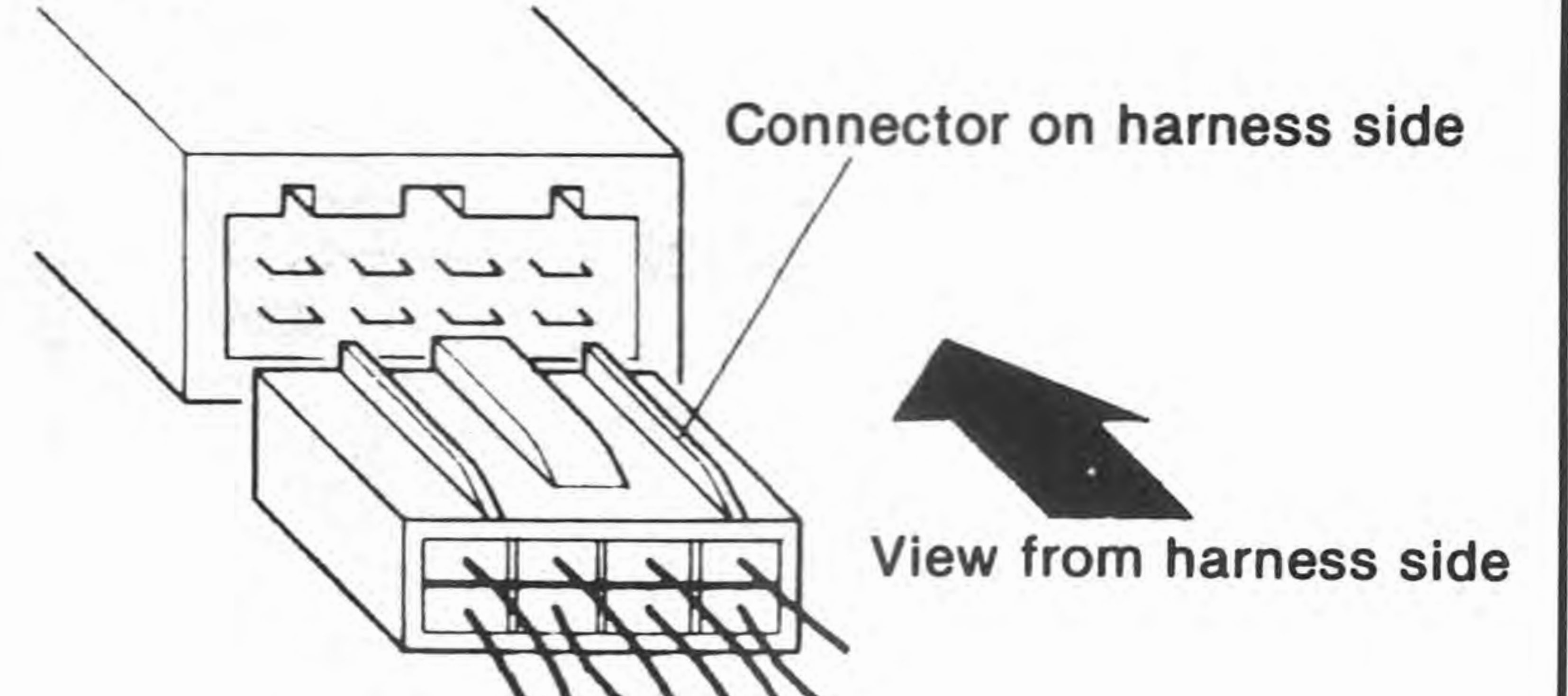

• Colors for connectors except milk-white are given in locations.
• Unused terminals are indicated by *.

Wire color code (harness symbol)

• Two-color wires are indicated by a two-letter symbol. The first indicates the base color of the wire, the second the color of the stripe.

For example:

W/R is a white wire with a red strip
BR/Y is a brown wire with a yellow strip

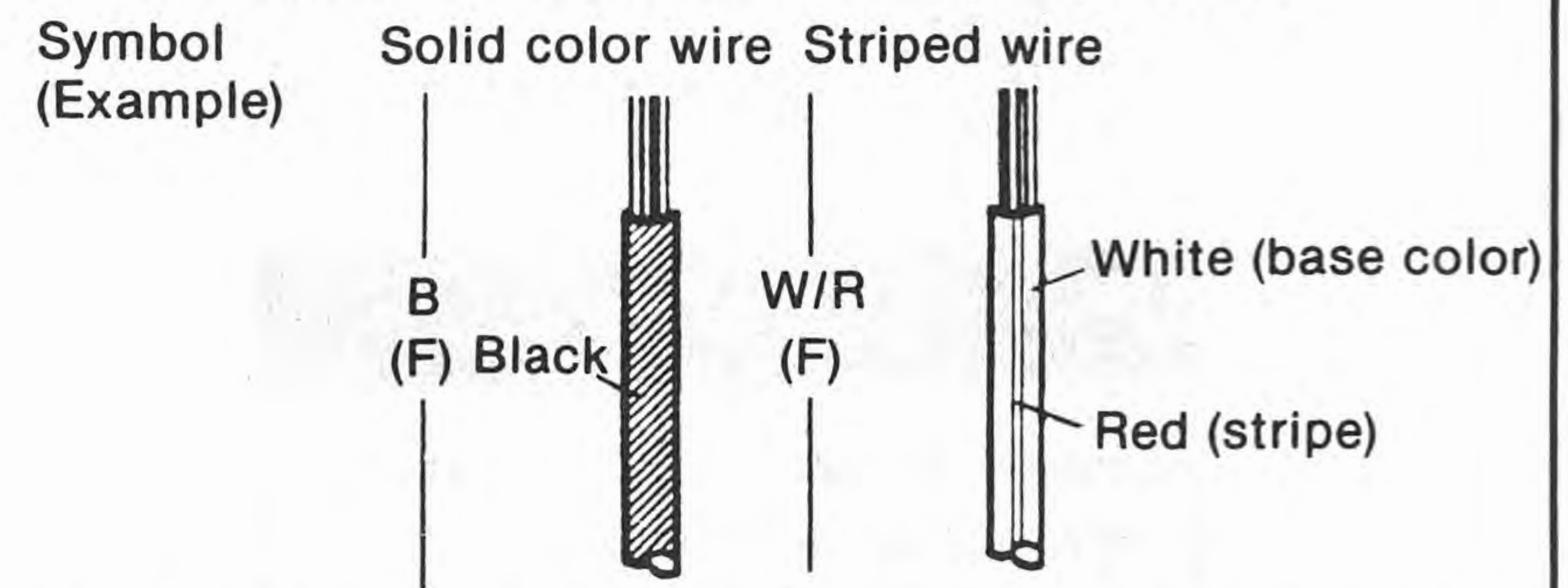

• The harness symbol is in () following the harness symbols (refer to GI-7.).

Routing diagram

- The routing diagram shows where electrical components are on the system circuit diagram by call out line and connector symbols.
- Specified values are listed beside the routing diagram or on the following page.

Connector symbol

Shows the system that uses the connector.

(Example)

Connector	Symbol
Joint box	JB-04
Common connectors	X-19
System connectors	I-03

Component name

Shows the names of components in routing diagrams.

Ground symbol

Shows the ground in system diagrams.

Engine control unit terminal (unit side)

2Y	2W	2U	2S	2O	2M	2K	2I	2G	2E	2C	2A	U	S	O	O	M	K	I	G	E	C	A	
2Z	2X	2V	2T	2R	2P	2N	2L	2J	2H	2F	2D	2B	V	I	R	P	N	L	J	H	F	D	B

Terminal	Input	Output	Connection to	Test condition	Voltage	Remark
1K	○		Diagnosis Connector	AI System Selector test switch "O ₂ MONITOR"	Approx. 12V	
				AI System Selector test switch "SELF-TEST"	Approx. 0V	
1N	○		Throttle sensor (idle point)	Accelerator pedal released	Approx. 0V	Ignition switch ON
				Accelerator pedal depressed	Approx. 12V	
1O	○		Stoplight switch	Brake pedal released	0V	
				Brake pedal depressed	Approx. 12V	
1P	○		P/S pressure switch	Ignition switch ON	Approx. 12V	
				P/S ON (at idle)	0V	
				P/S OFF (at idle)	Approx. 12V	
1R	○		Fan switch	Fan operating (Engine coolant temperature over 97°C (207°F) or diagnosis connector terminal TFA grounded)	Approx. 0V	
				Fan not operating (idle)	Approx. 12V	
1U	○		Headlight switch	Headlights ON (Taxi, parking, low beam or high beam)	Approx. 12V	
				Headlights OFF	Approx. 0V	
1V	○		Neutral or clutch switch	Neutral position or clutch pedal depressed	Approx. 10V	
				Other conditions	Approx. 12V	
2A	-	-	Ground (Injector)	Constant	0V	
2B	-	-	Ground (Output)	Constant	0V	
2C	-	-	Ground (CPU)	Constant	0V	
2D	-	-	Ground (Input)	Constant	0V	
2E	○		Crank angle sensor (Ne signal)	Ignition switch ON	Approx. 0V or 5V	
				Idle	Approx. 12V	
2G	○		Crank angle sensor (G signal)	Ignition switch ON	Approx. 0V or 5V	
				Idle	Approx. 1.5V	
2J	○		Ground	Constant	0V	
2K	○		Airflow meter	Constant	4.5 - 5.5V	
2L	○		Throttle sensor (Power terminal)	Accelerator pedal released	Approx. 5V	
				Accelerator pedal fully depressed	Approx. 0V	
2N	○		Oxygen sensor	Ignition switch ON	0V	
				Idle (Cold engine)	0V	
				Idle (After warm up)	0 - 1V	
				Increase engine speed (After warm up)	0.5 - 1V	
				Deceleration	0 - 0.4V	
2O	○		Airflow meter	Ignition switch ON	Approx. 3.8V	
				Idle	Approx. 3.3V	
2P	○		Airflow sensor (Intake air thermostensor)	At 20°C (68°F)	Approx. 2.5V	
2Q	○		Water thermostensor	Engine coolant temperature 20°C (68°F)	Approx. 2.5V	
				After warm up	Approx. 0.4V	

JOINT BOX

Specified values

Shows values for determining whether an electrical component is good.

HARNESS SYMBOLS



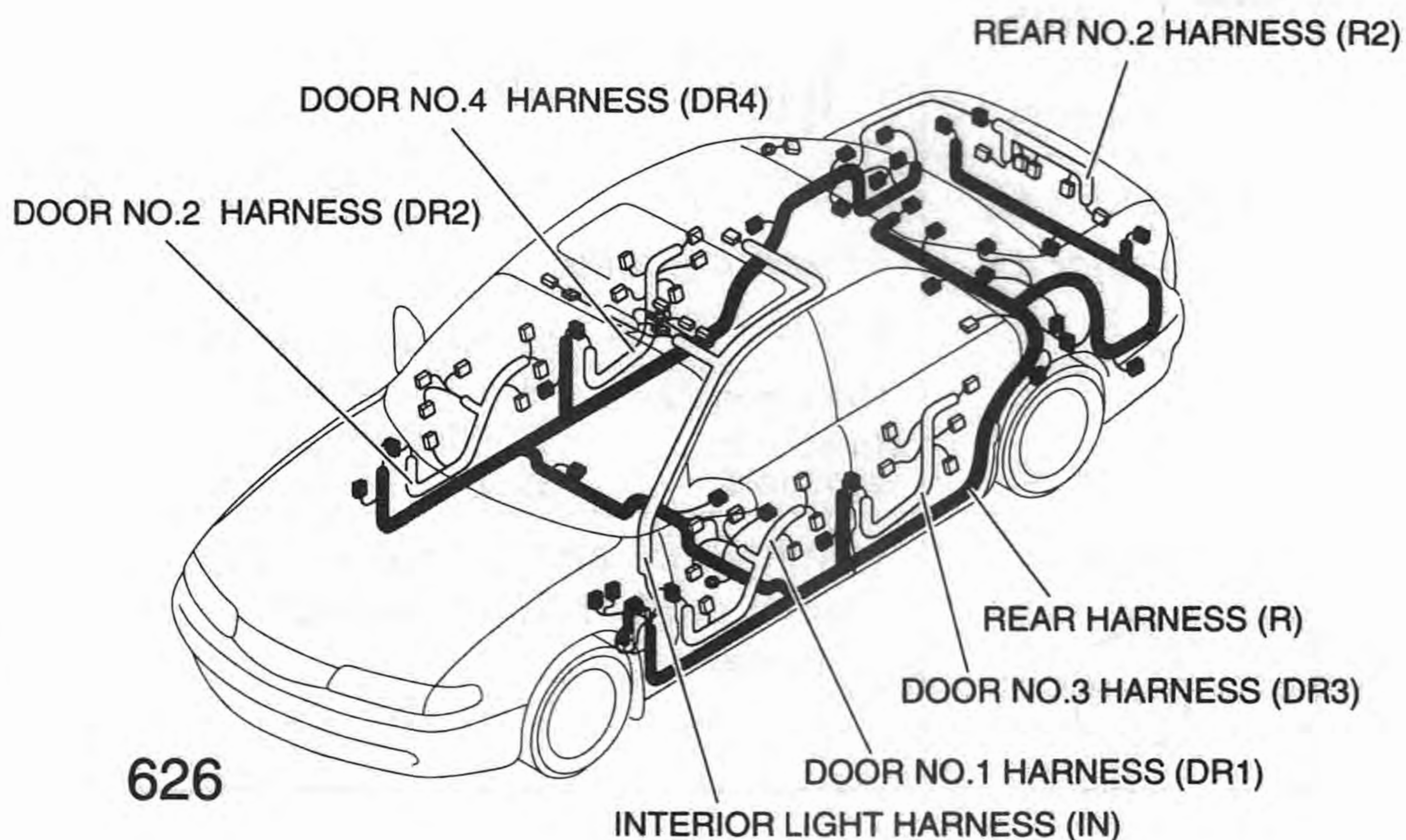
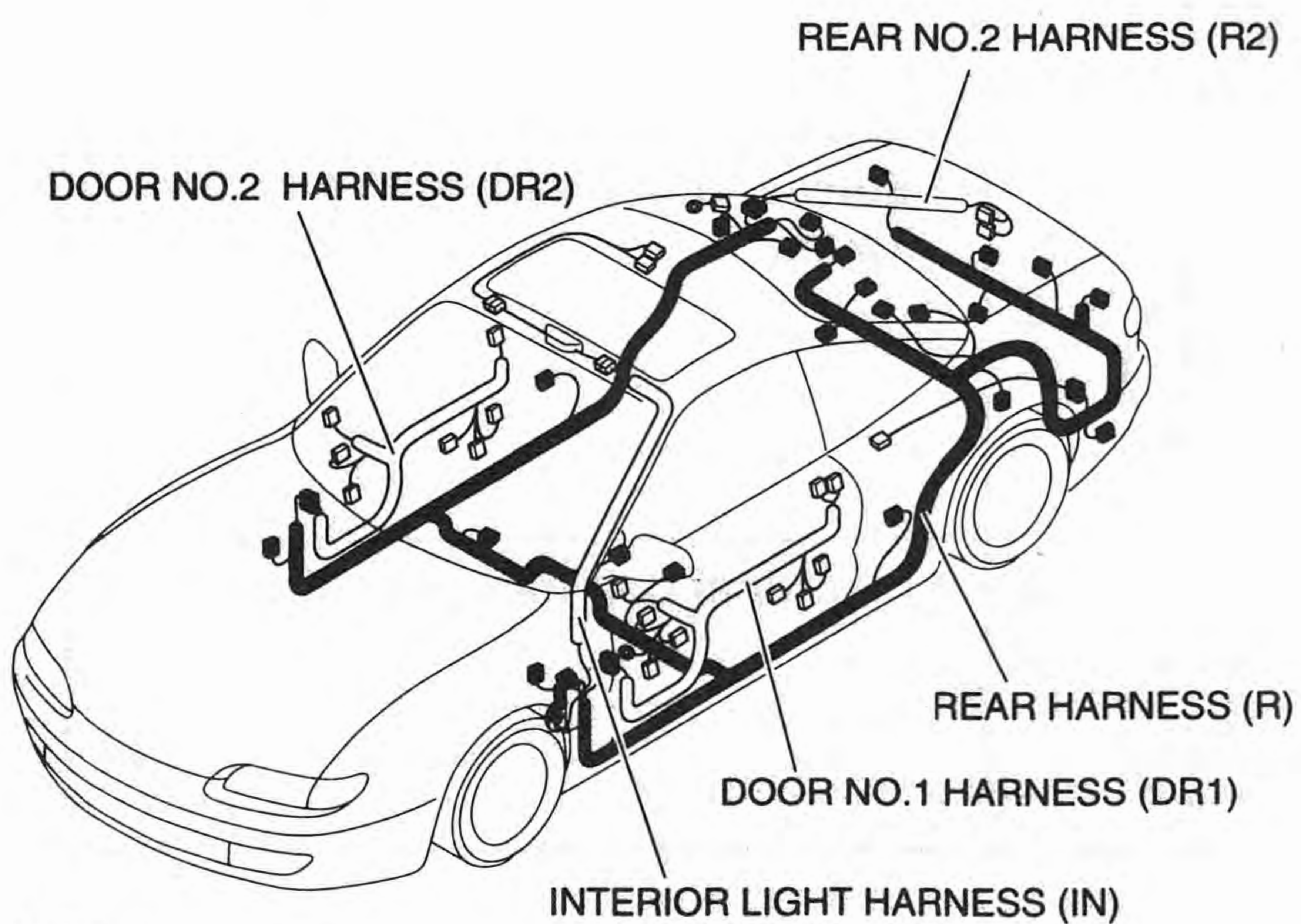
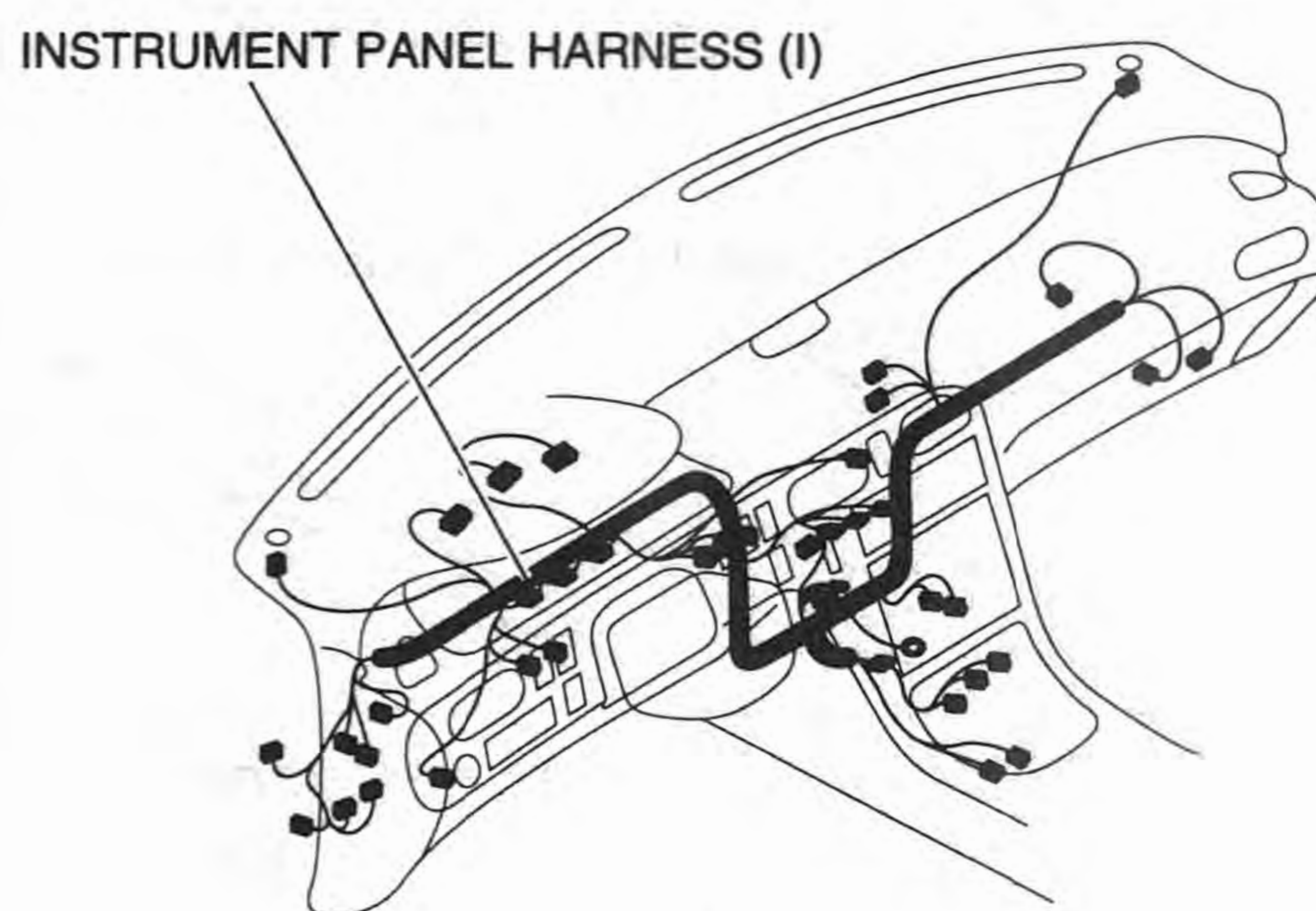
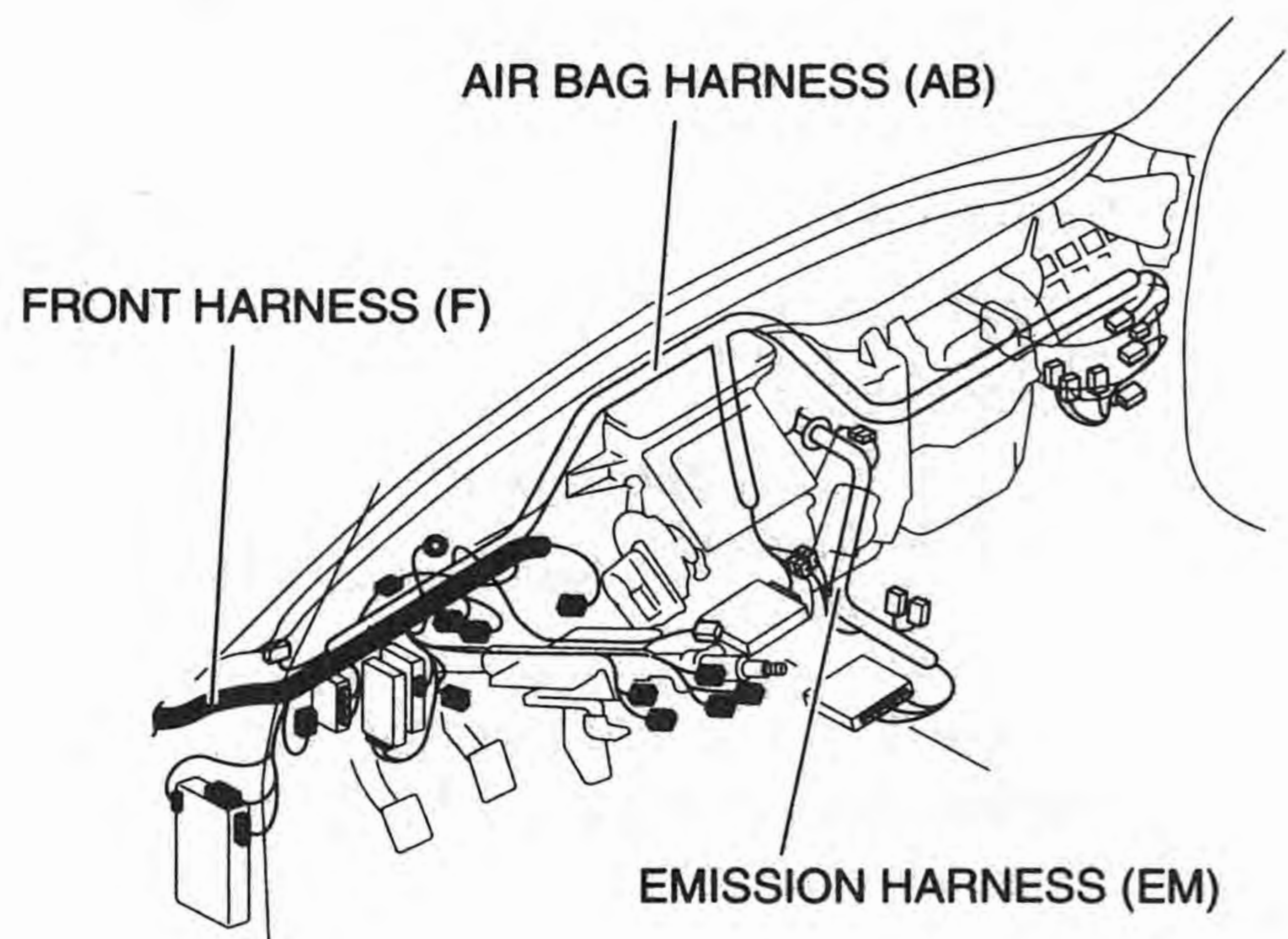
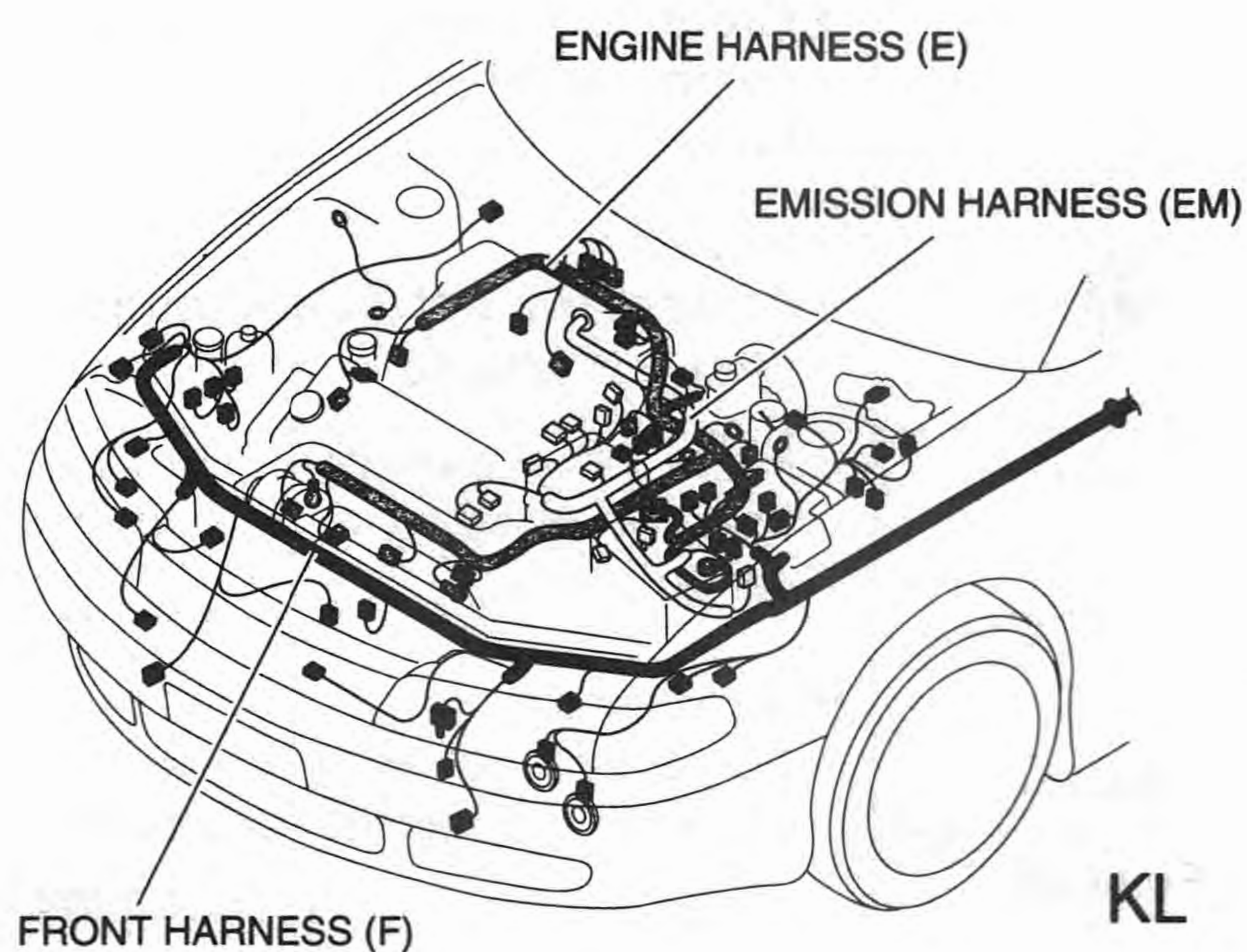
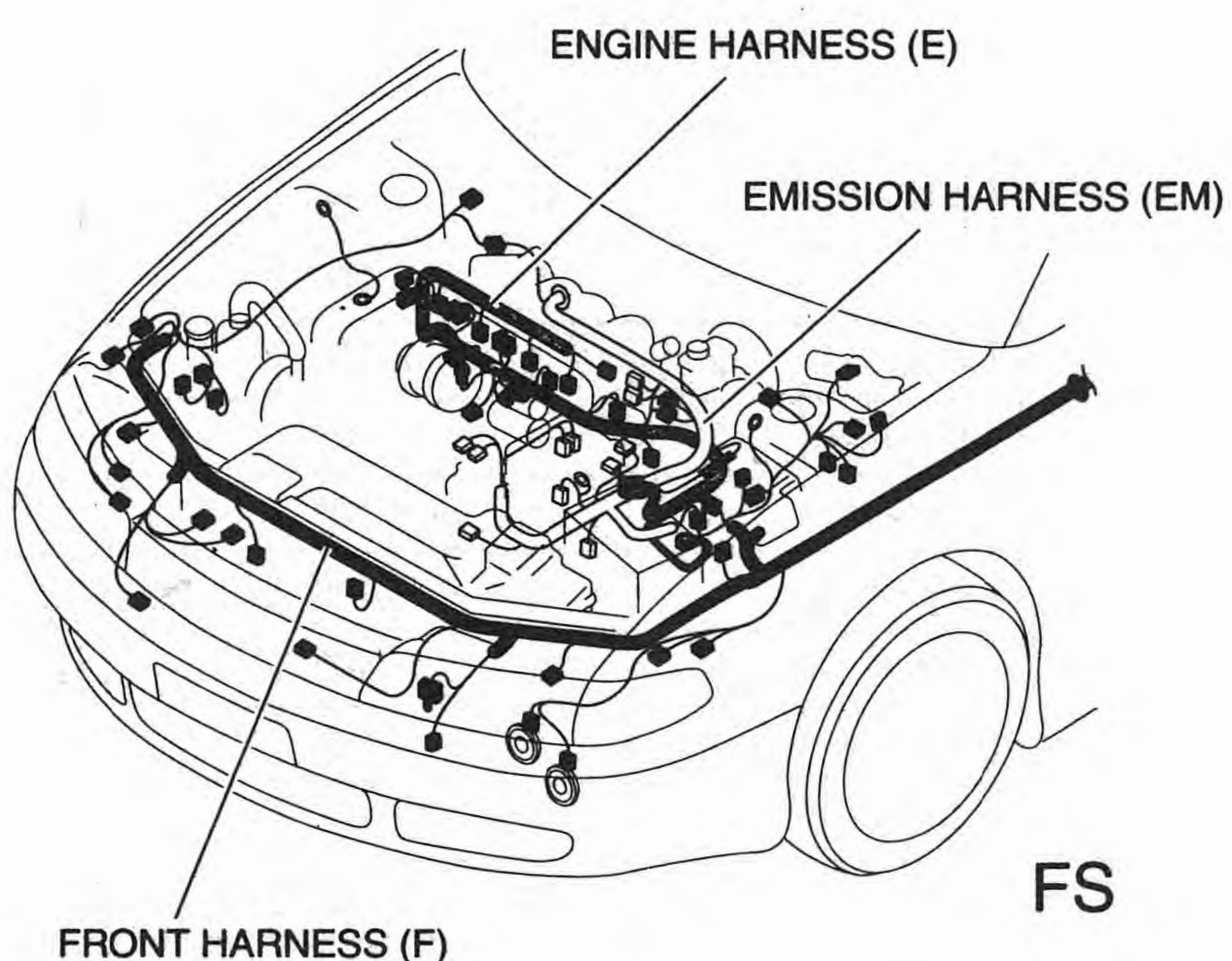







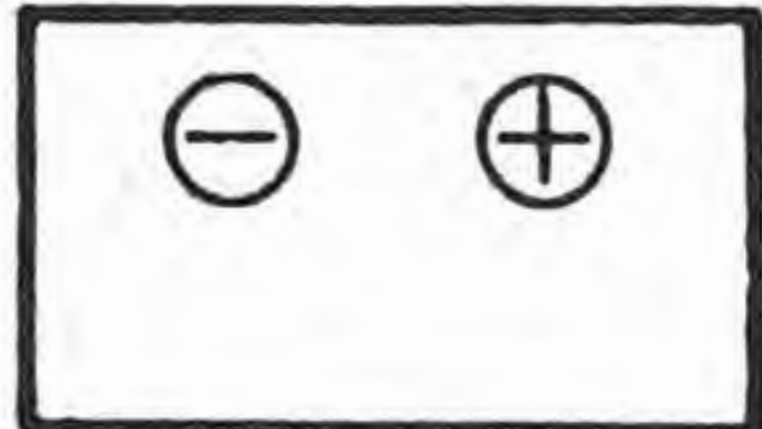

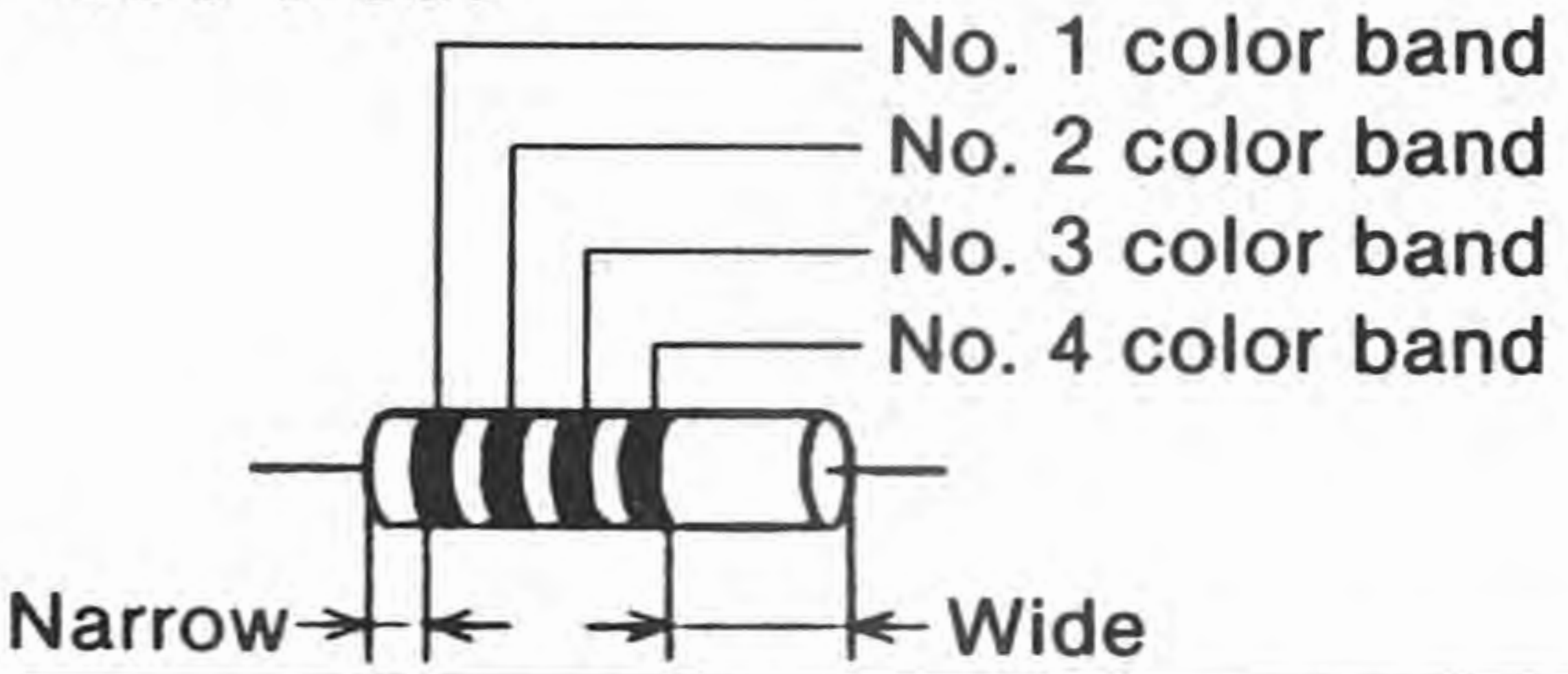
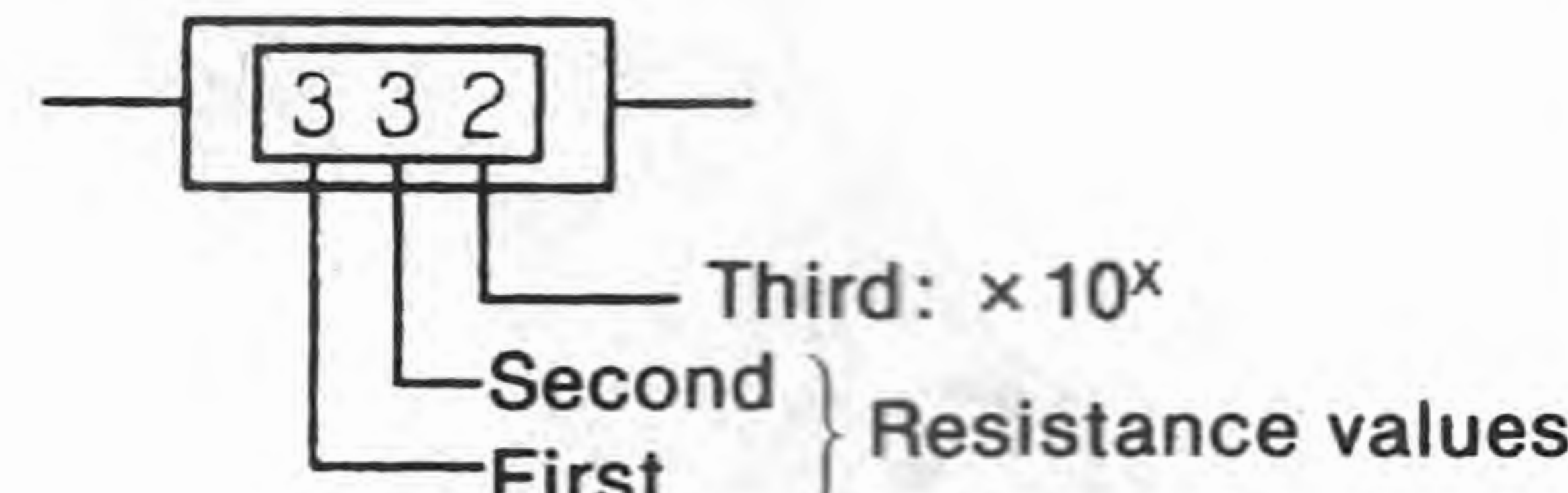
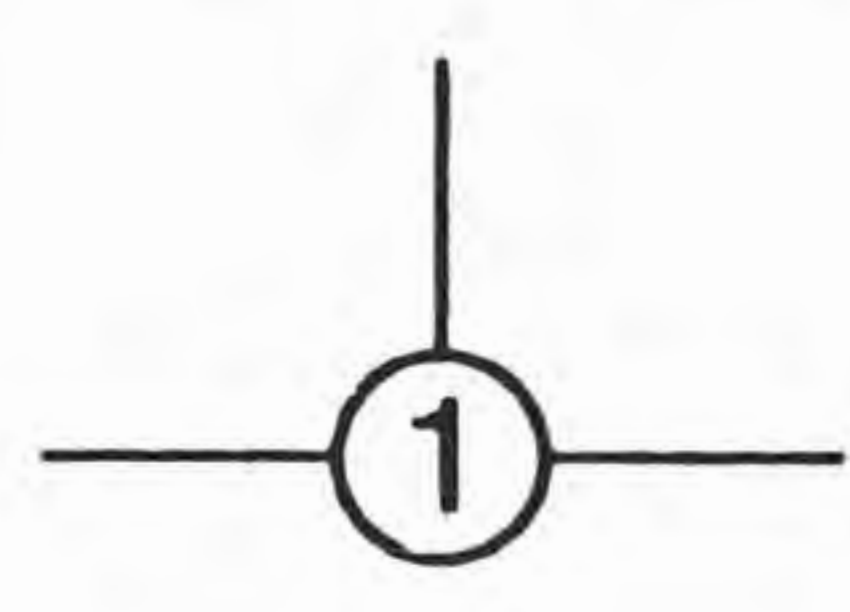
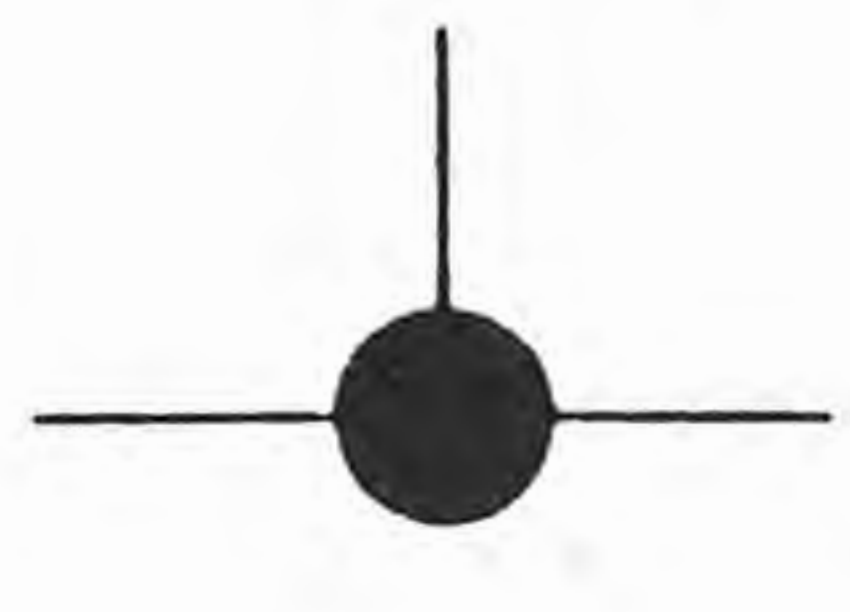
DESCRIPTION OF HARNESS	COLOR	SYMBOL	DESCRIPTION OF HARNESS	SYMBOL
FRONT HARNESS	■	(F)	INTERIOR LIGHT HARNESS	(IN)
ENGINE HARNESS	■	(E)	DOOR NO.1 HARNESS	(DR1)
INSTRUMENT PANEL HARNESS	■	(I)	DOOR NO.2 HARNESS	(DR2)
REAR HARNESS	■	(R)	DOOR NO.3 HARNESS	(DR3)
REAR NO.2 HARNESS		(R2)	DOOR NO.4 HARNESS	(DR4)
EMISSION HARNESS		(EM)	AIR BAG HARNESS	(AB)

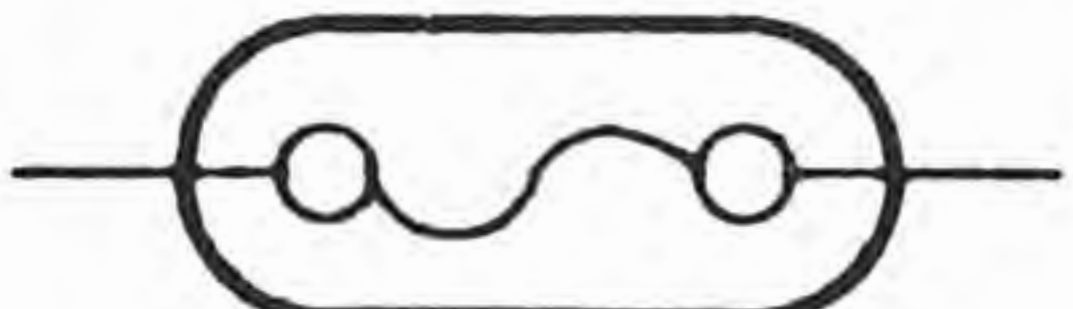
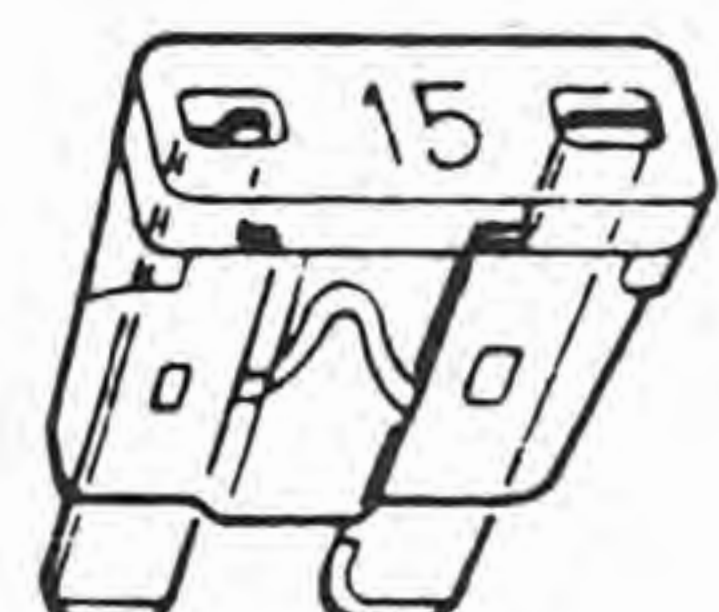
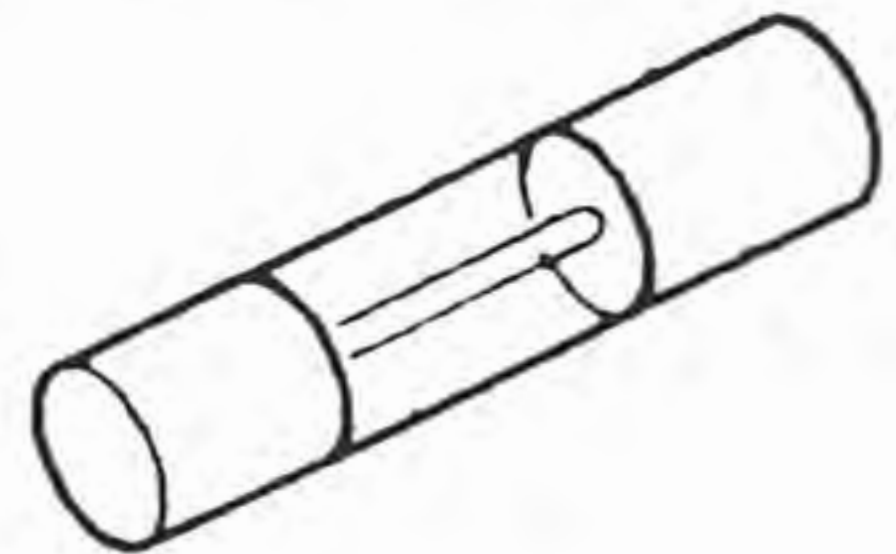

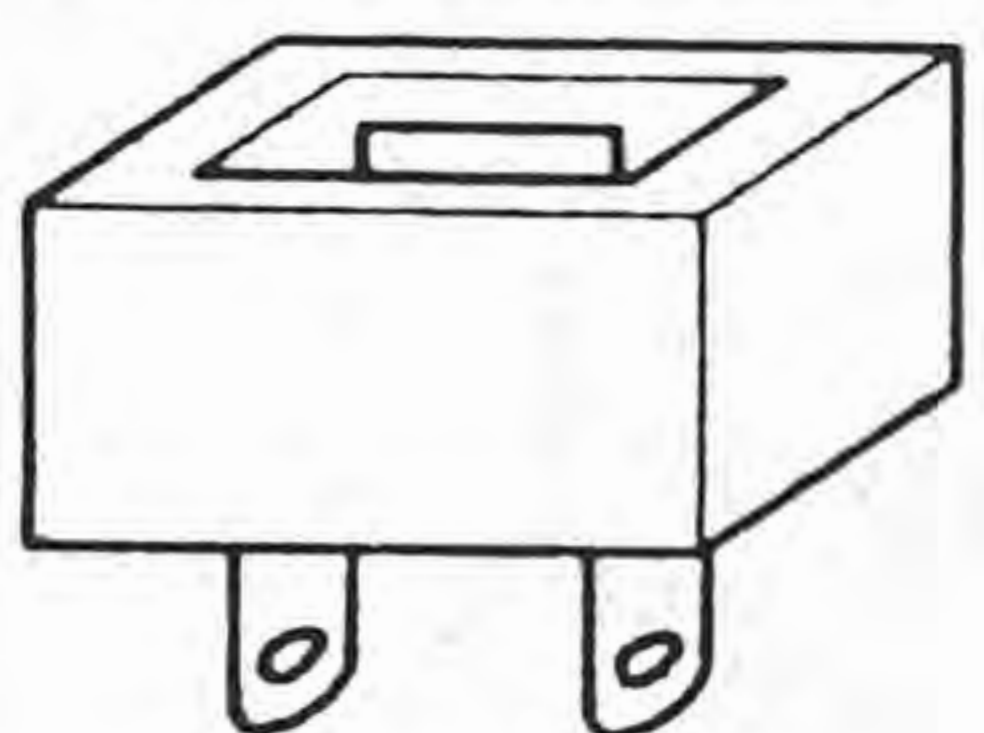
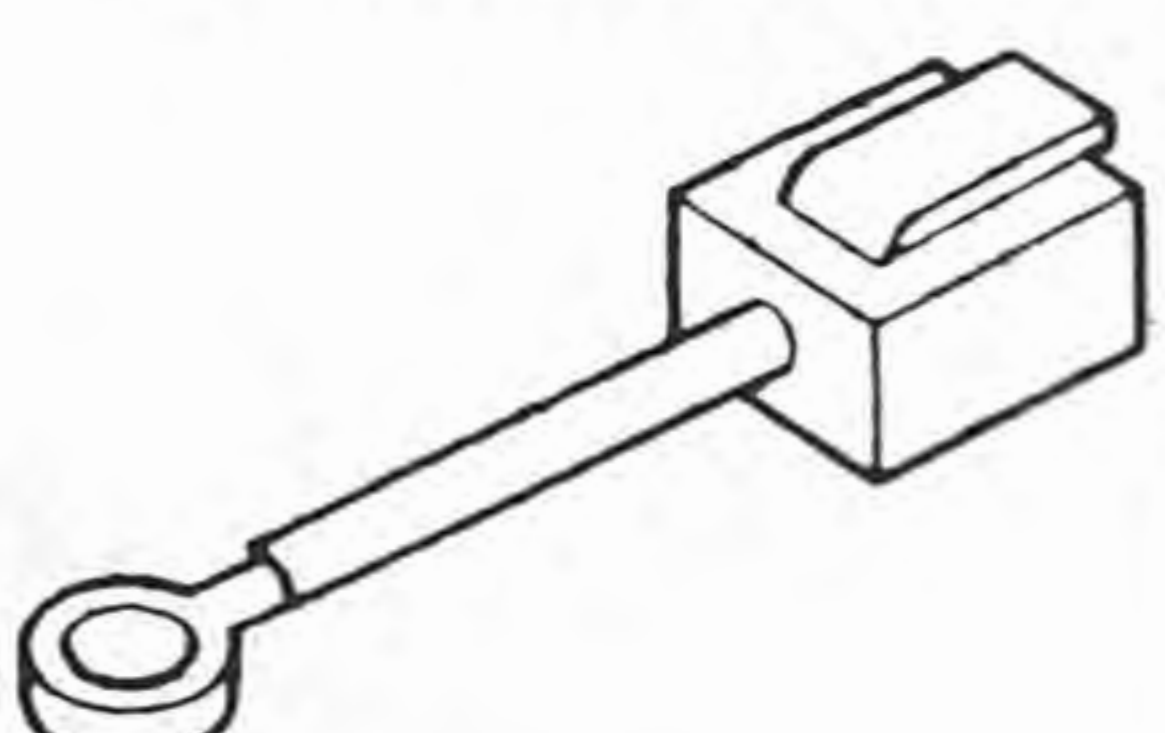
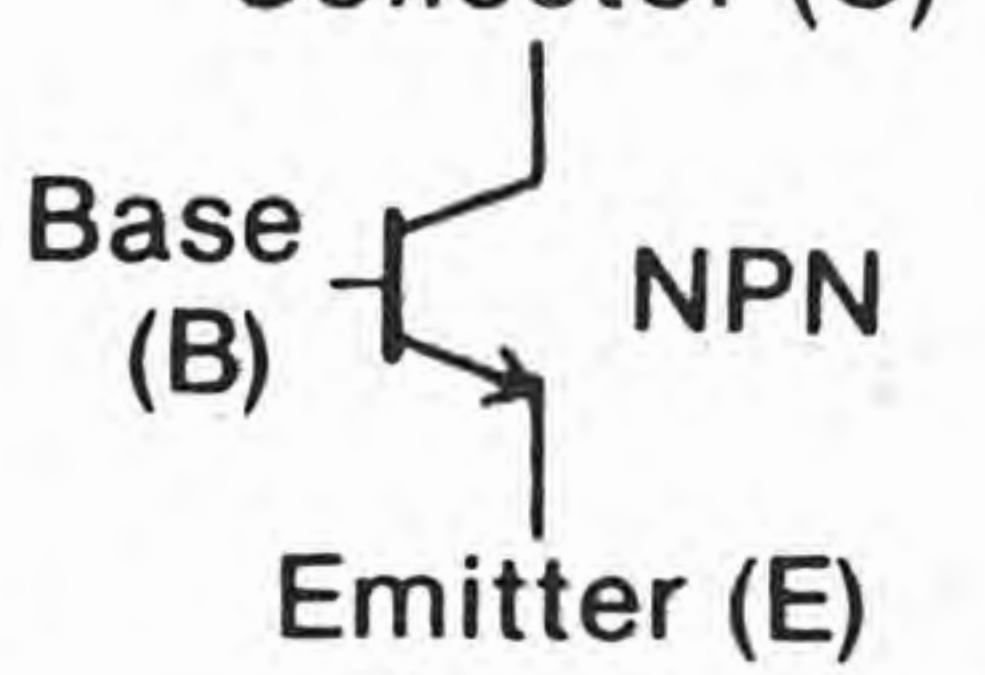
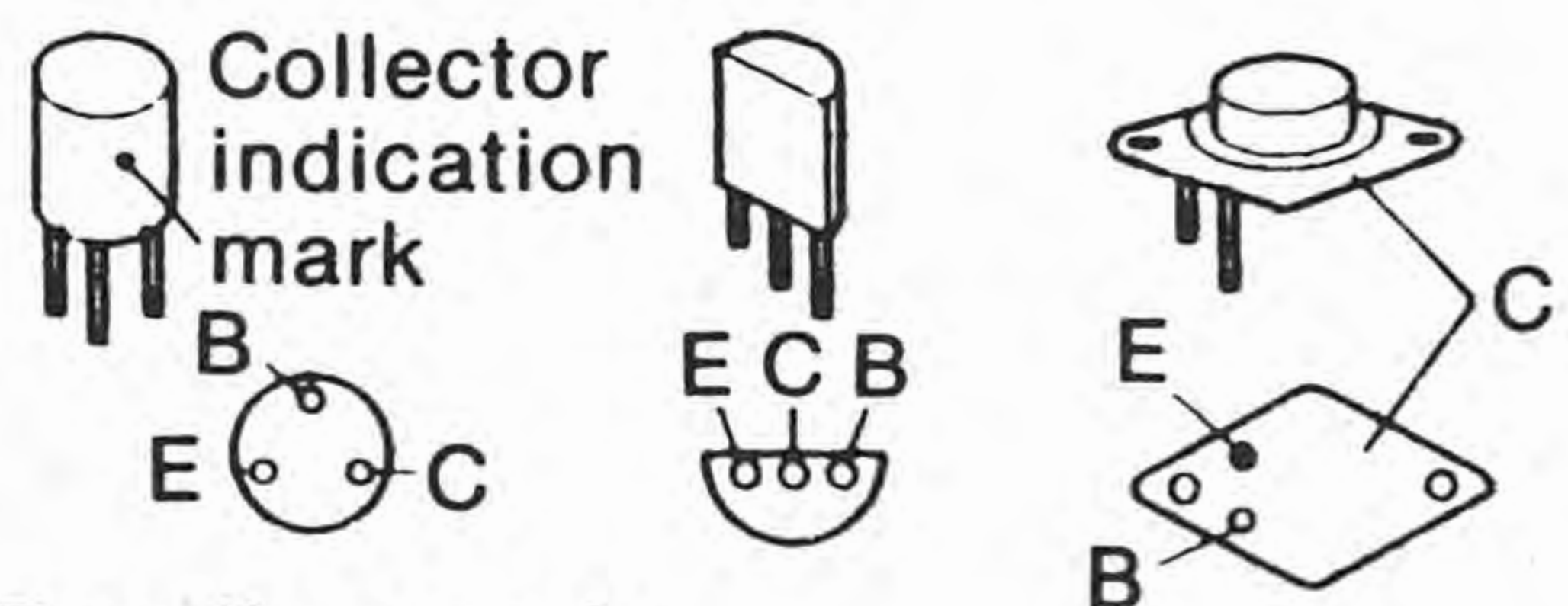

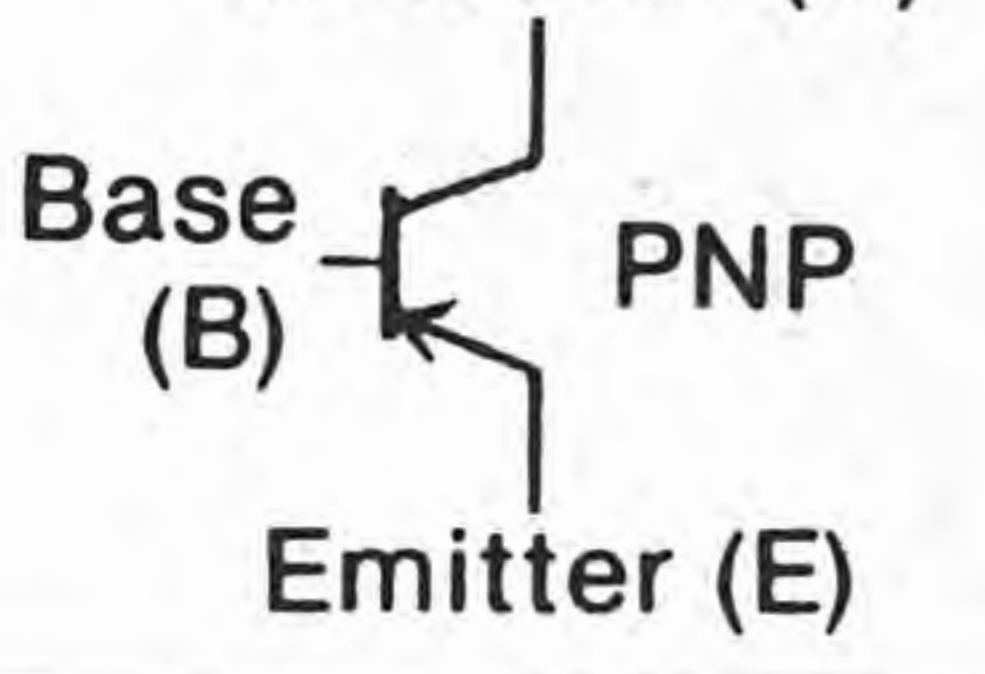





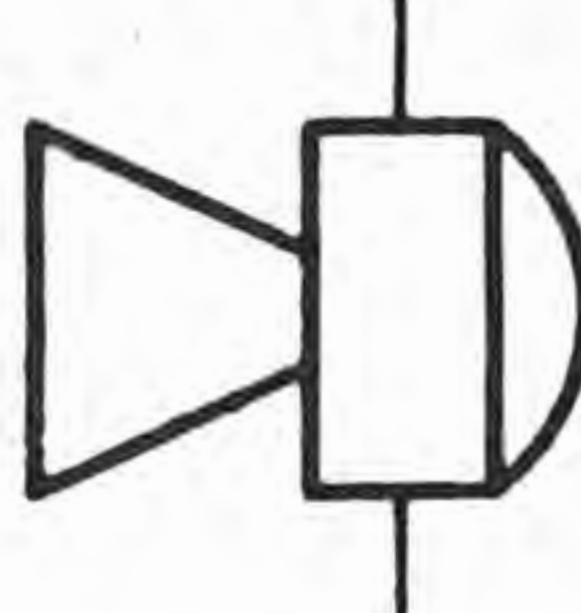
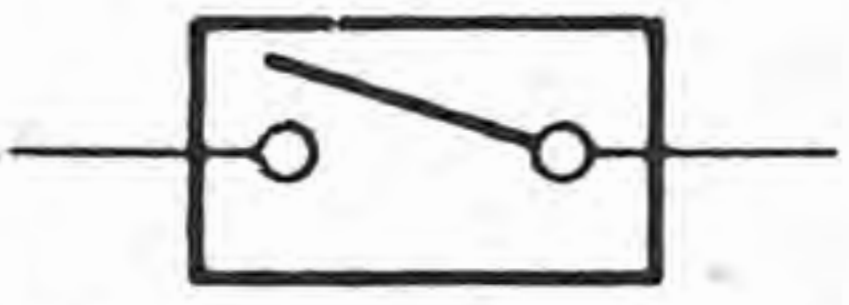

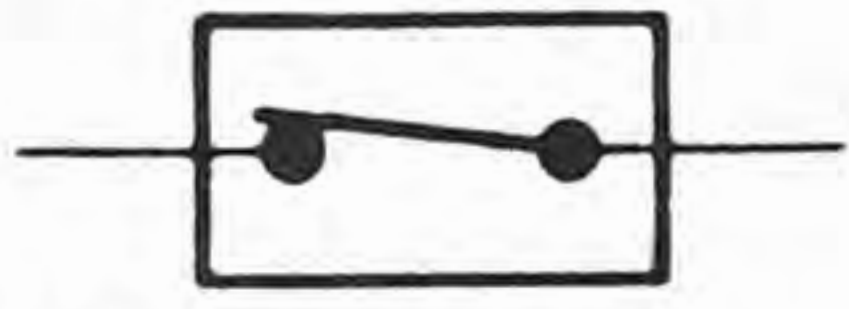
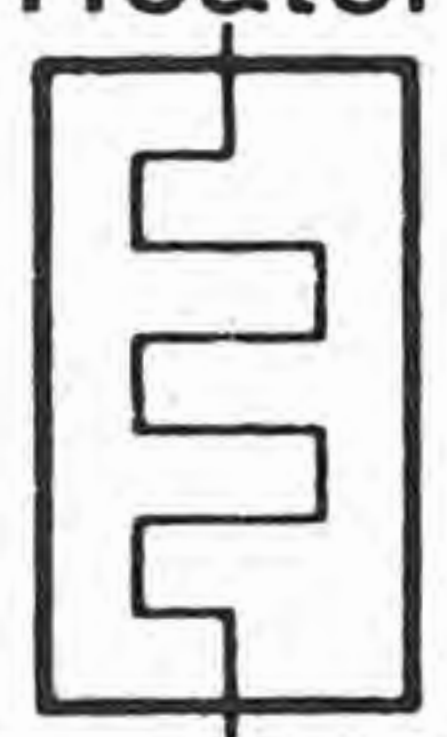
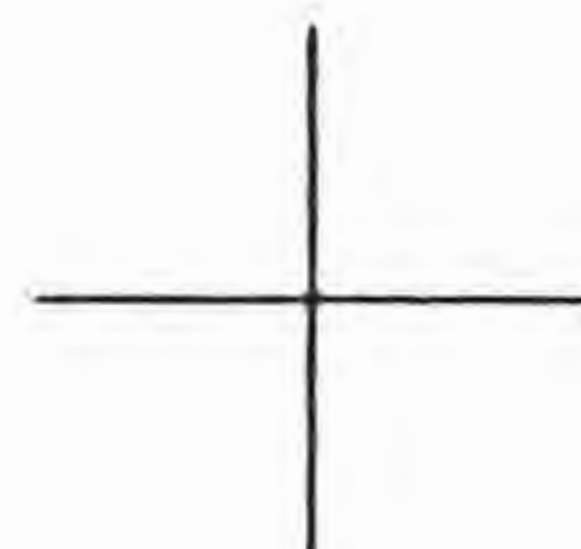

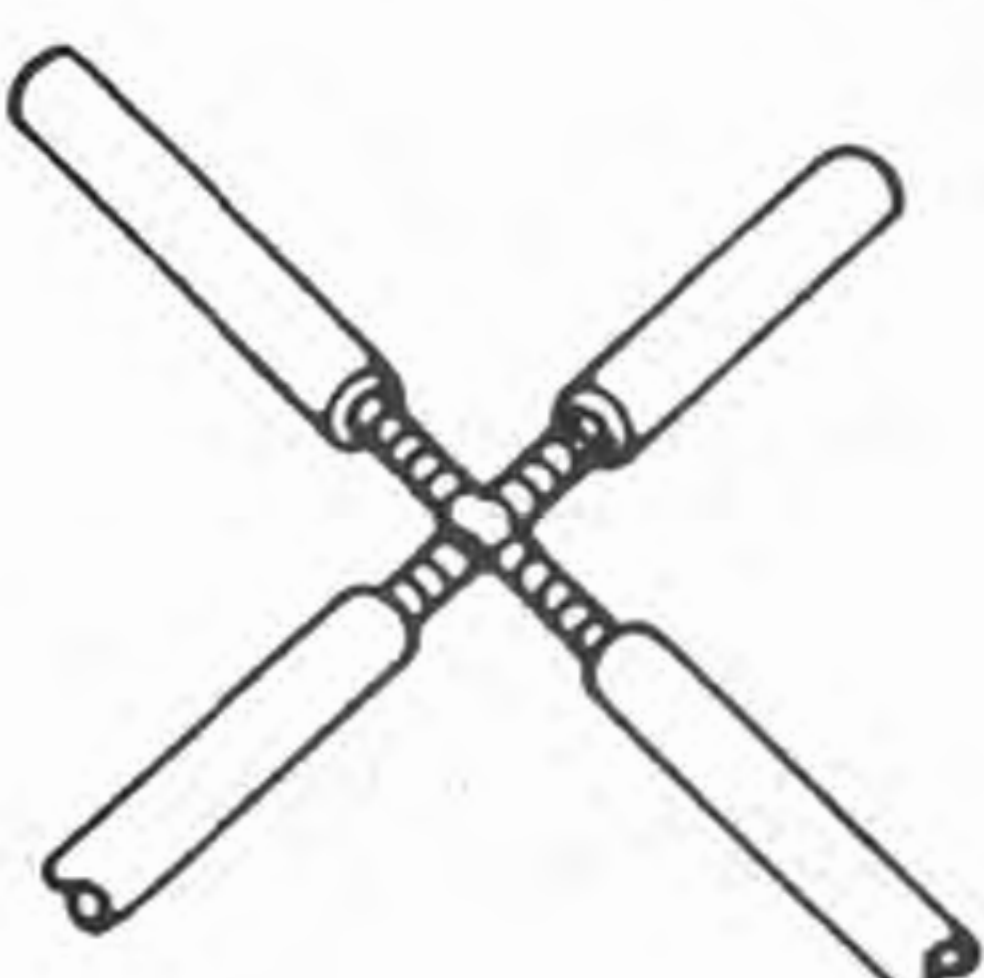
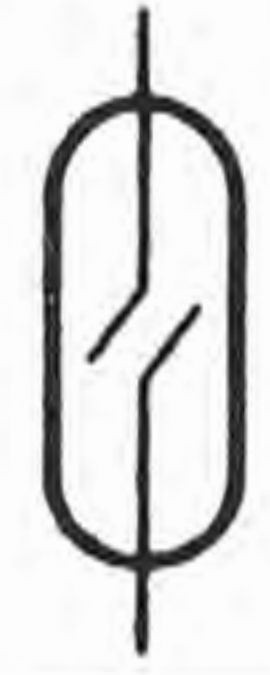
MX-6

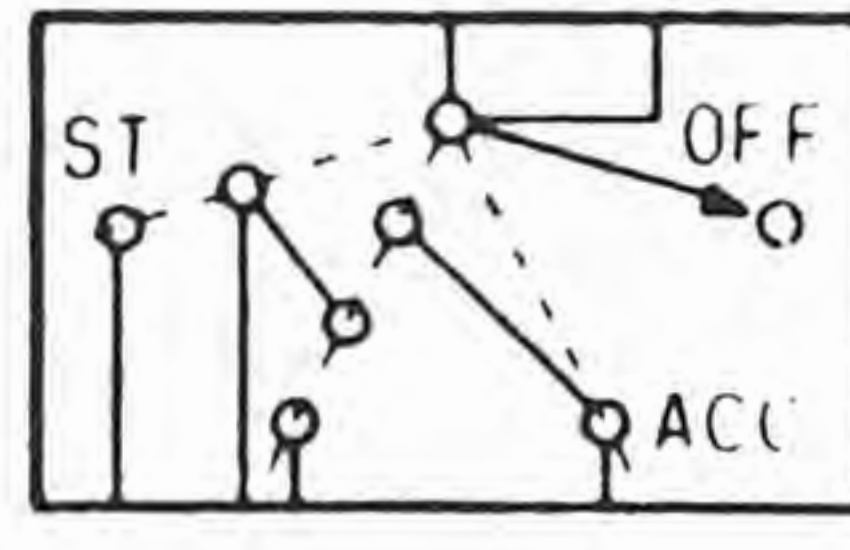
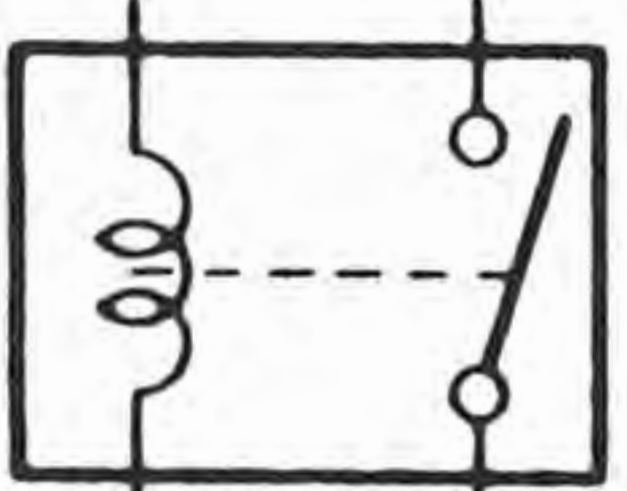
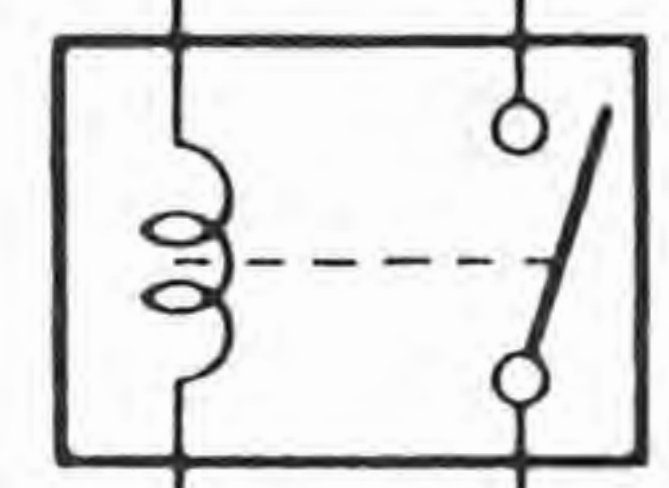
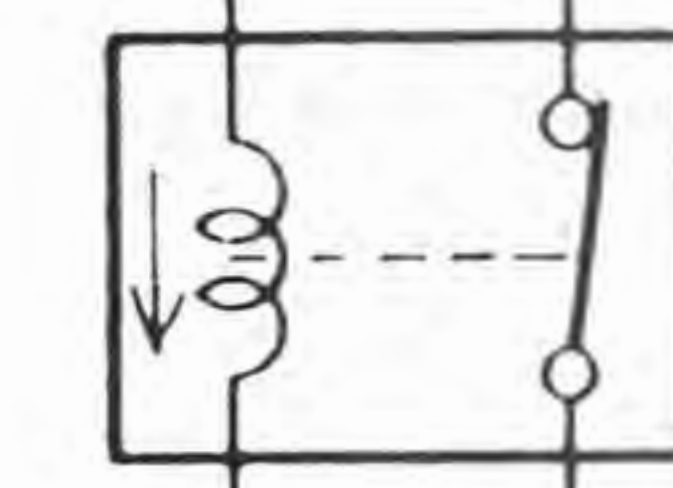
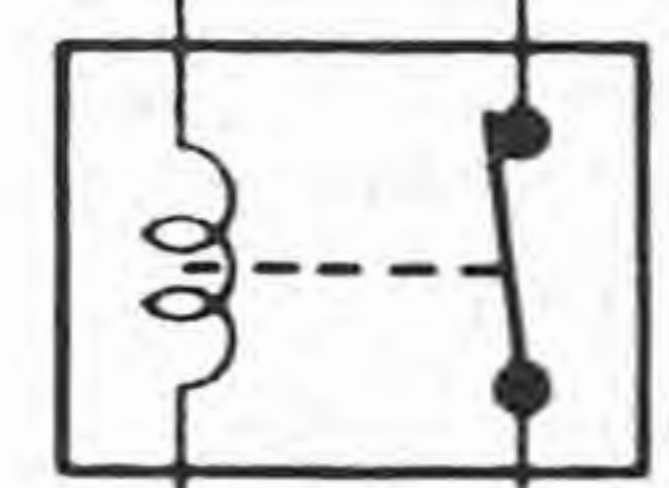
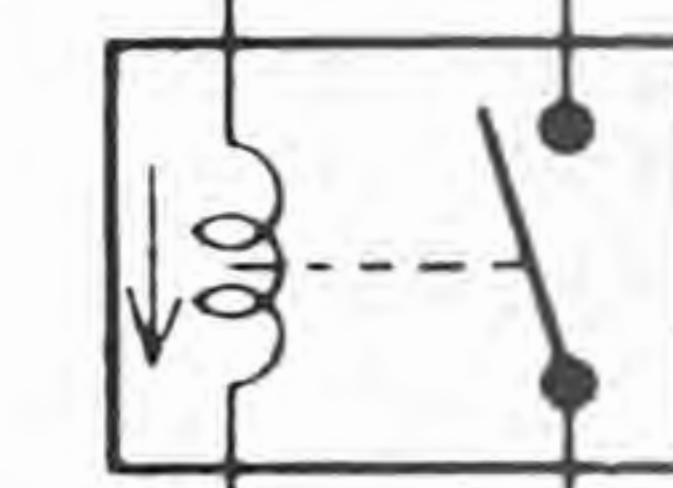
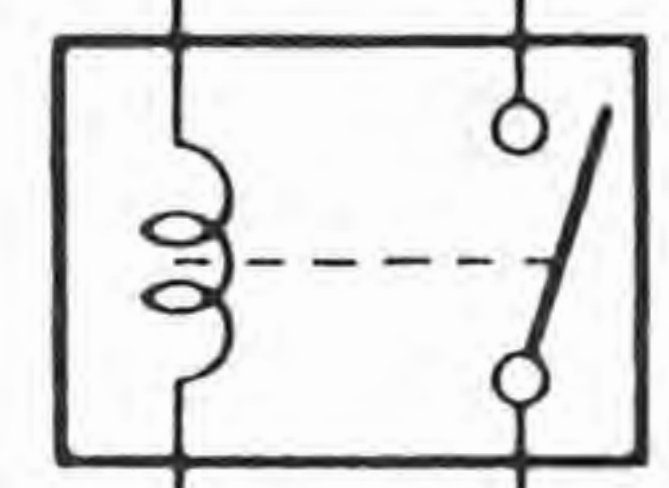
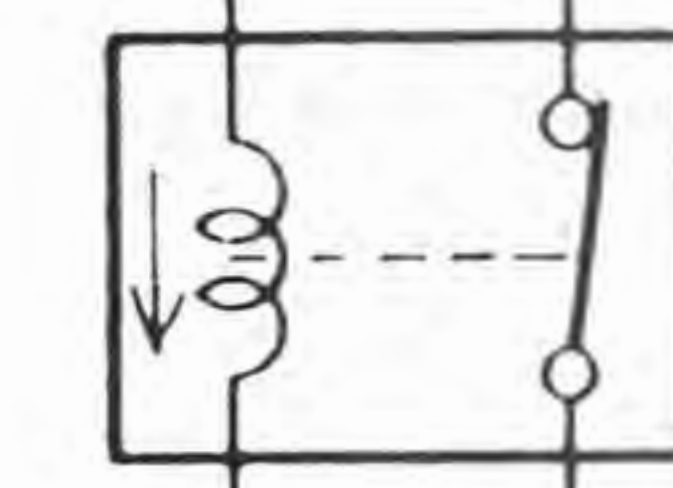
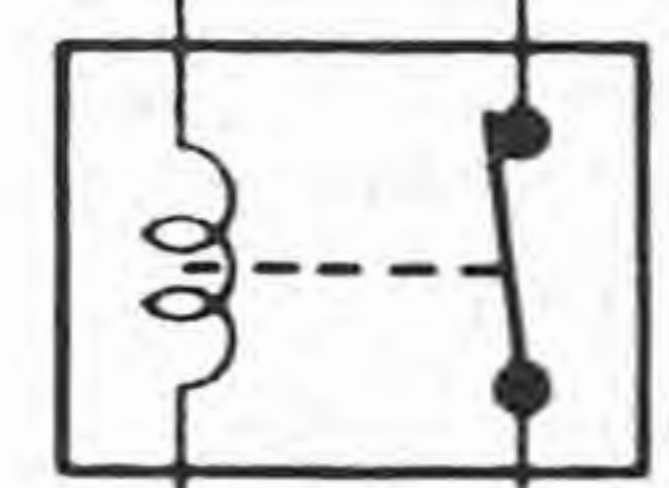
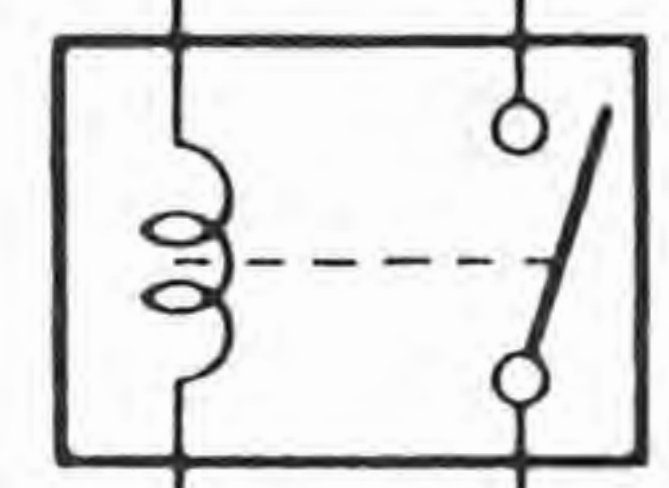
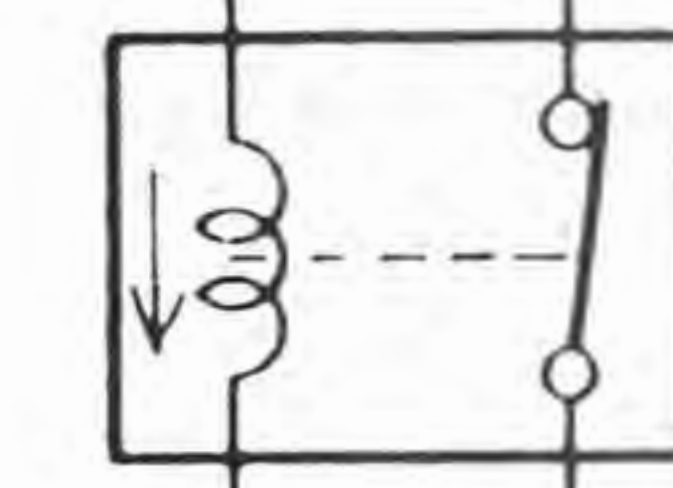
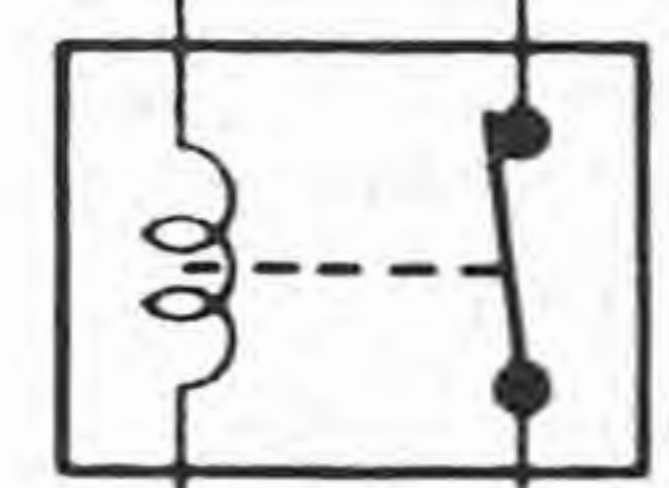
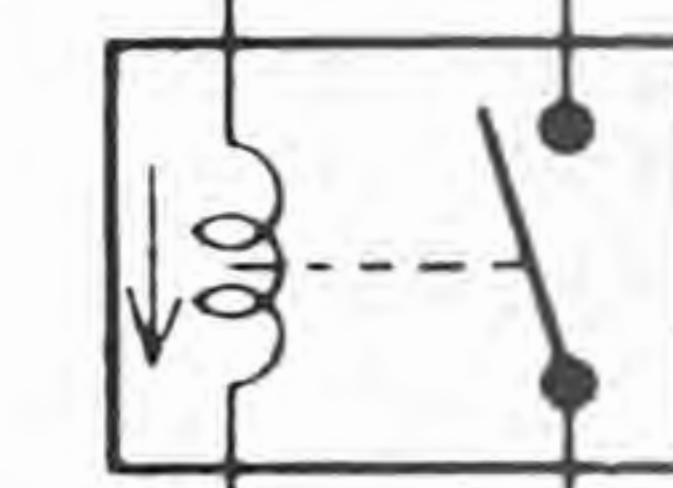
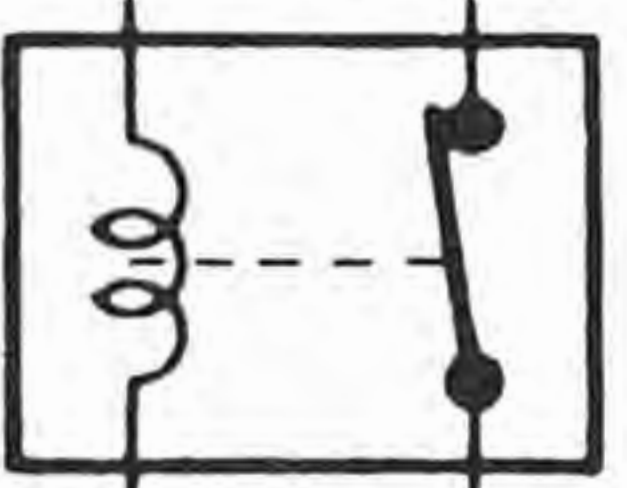
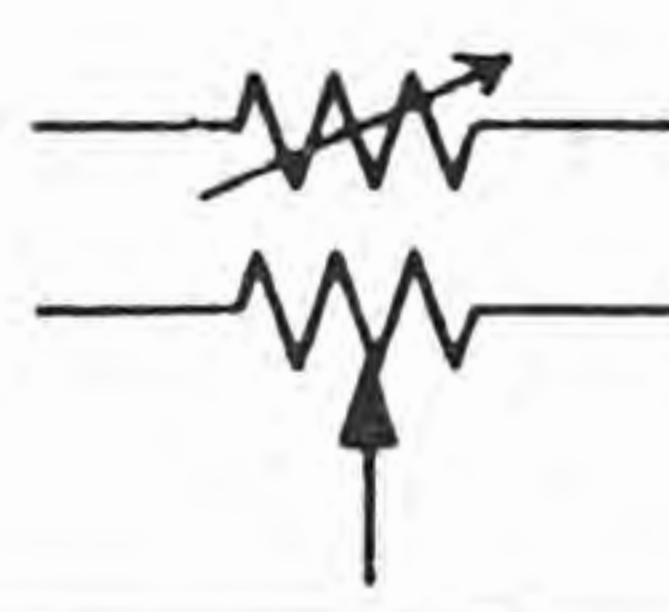



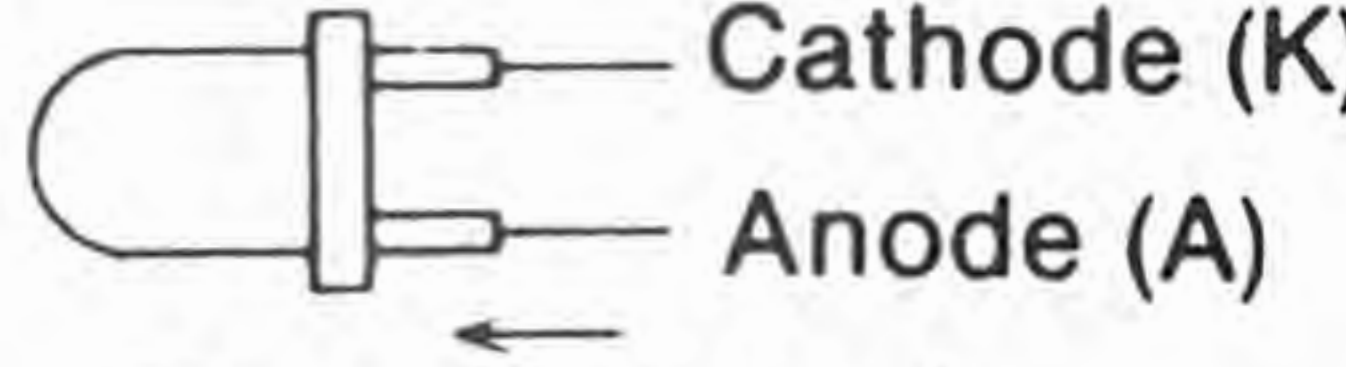
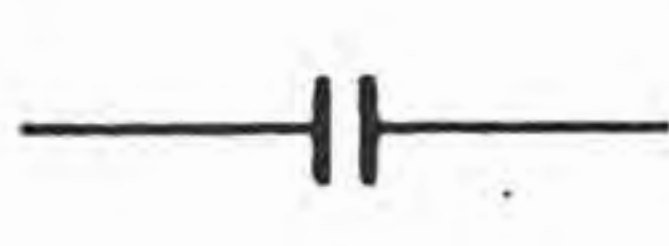

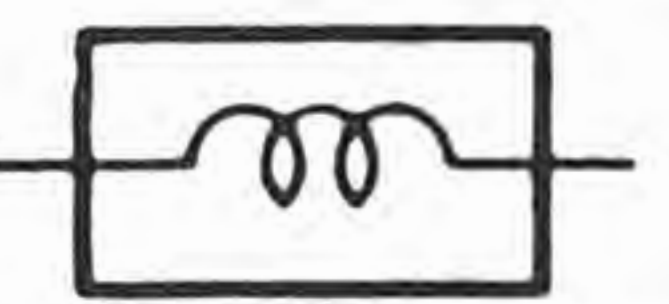
626

Symbols

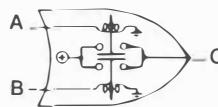
Symbol	Meaning	Symbol	Meaning																																																																										
<p>Battery</p> 	<ul style="list-style-type: none"> Generates electricity through chemical reaction. Supplies direct current to circuits. 	<p>Resistance</p> 	<ul style="list-style-type: none"> A resistor with a constant value. Mainly used to protect electrical components in circuits by maintaining rated voltage. Reading resistance values. <p><Colored></p>  <table border="1"> <thead> <tr> <th rowspan="2">Color</th> <th>No. 1</th> <th>No. 2</th> <th>No. 3</th> <th>No. 4</th> </tr> <tr> <th colspan="2">Resistance values</th> <th>Multiplier</th> <th>Tolerance</th> </tr> </thead> <tbody> <tr><td>Black</td><td>0</td><td>0</td><td>$\times 10^0$</td><td></td></tr> <tr><td>Brown</td><td>1</td><td>1</td><td>$\times 10^1$</td><td></td></tr> <tr><td>Red</td><td>2</td><td>2</td><td>$\times 10^2$</td><td></td></tr> <tr><td>Orange</td><td>3</td><td>3</td><td>$\times 10^3$</td><td></td></tr> <tr><td>Yellow</td><td>4</td><td>4</td><td>$\times 10^4$</td><td></td></tr> <tr><td>Green</td><td>5</td><td>5</td><td>$\times 10^5$</td><td></td></tr> <tr><td>Blue</td><td>6</td><td>6</td><td>$\times 10^6$</td><td></td></tr> <tr><td>Purple</td><td>7</td><td>7</td><td>$\times 10^7$</td><td></td></tr> <tr><td>Grey</td><td>8</td><td>8</td><td>$\times 10^8$</td><td></td></tr> <tr><td>White</td><td>9</td><td>9</td><td>$\times 10^9$</td><td></td></tr> <tr><td>Gold</td><td></td><td></td><td>$\times 10^{-1}$</td><td>$\pm 5\%$</td></tr> <tr><td>Silver</td><td></td><td></td><td>$\times 10^{-2}$</td><td>$\pm 10\%$</td></tr> <tr><td>—</td><td></td><td></td><td></td><td>$\pm 20\%$</td></tr> </tbody> </table> <p><Numerical></p> 	Color	No. 1	No. 2	No. 3	No. 4	Resistance values		Multiplier	Tolerance	Black	0	0	$\times 10^0$		Brown	1	1	$\times 10^1$		Red	2	2	$\times 10^2$		Orange	3	3	$\times 10^3$		Yellow	4	4	$\times 10^4$		Green	5	5	$\times 10^5$		Blue	6	6	$\times 10^6$		Purple	7	7	$\times 10^7$		Grey	8	8	$\times 10^8$		White	9	9	$\times 10^9$		Gold			$\times 10^{-1}$	$\pm 5\%$	Silver			$\times 10^{-2}$	$\pm 10\%$	—				$\pm 20\%$
Color	No. 1	No. 2	No. 3		No. 4																																																																								
	Resistance values		Multiplier	Tolerance																																																																									
Black	0	0	$\times 10^0$																																																																										
Brown	1	1	$\times 10^1$																																																																										
Red	2	2	$\times 10^2$																																																																										
Orange	3	3	$\times 10^3$																																																																										
Yellow	4	4	$\times 10^4$																																																																										
Green	5	5	$\times 10^5$																																																																										
Blue	6	6	$\times 10^6$																																																																										
Purple	7	7	$\times 10^7$																																																																										
Grey	8	8	$\times 10^8$																																																																										
White	9	9	$\times 10^9$																																																																										
Gold			$\times 10^{-1}$	$\pm 5\%$																																																																									
Silver			$\times 10^{-2}$	$\pm 10\%$																																																																									
—				$\pm 20\%$																																																																									
<p>Ground (1)</p> 	<ul style="list-style-type: none"> Connecting point to vehicle body or other ground wire where current flows from positive to negative terminal of battery. Ground (1) indicates a ground point to body through wire harness. Ground (2) indicates point where component is grounded directly to body. <p>Remarks</p> <ul style="list-style-type: none"> Current will not flow through a circuit if ground is faulty. 																																																																												
<p>Ground (2)</p> 																																																																													
<p>Fuse (1)</p>  <p>(box)</p>	<ul style="list-style-type: none"> Melts when current flow exceeds that specified for circuit, interrupts current flow. <p>Precautions</p> <ul style="list-style-type: none"> Do not replace with fuses exceeding specified capacity. 																																																																												
<p>Fuse (2)</p>  <p>(Cartridge)</p>		<p><Blade type></p>  <p><Tube type></p> 																																																																											
<p>Main fuse/ Fusible link</p> 		<p><Cartridge type></p>  <p><Fusible link></p> 																																																																											
<p>Transistor (1)</p> <p>Collector (C)</p>  <p>Base (B)</p> <p>Emitter (E)</p> <p>NPN</p>	<ul style="list-style-type: none"> Electrical switching component. Turns on when voltage is applied to the base (B). <p>Collector indication mark</p>  <p>Reading code.</p> <p>2 S C 828 A</p> <p>Semiconductor</p> <p>Number of terminals</p> <p>Revision mark</p> <p>A: High-frequency PNP B: Low-frequency PNP C: High-frequency NPN D: Low-frequency NPN</p>	<p>Motor</p> 	<ul style="list-style-type: none"> Converts electrical energy into mechanical energy. 																																																																										
<p>Transistor (2)</p> <p>Collector (C)</p>  <p>Base (B)</p> <p>Emitter (E)</p> <p>PNP</p>			<p>Pump</p> 	<ul style="list-style-type: none"> Pulls in and discharges gases and liquids. 																																																																									
<p>Lamp</p>  <p>3.4W</p>	<ul style="list-style-type: none"> Emits light and generates heat when current flows through filament. 	<p>Cigarette lighter</p> 	<ul style="list-style-type: none"> Electrical coil that generates heat. 																																																																										

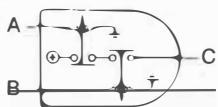
Symbol	Meaning	Symbol	Meaning							
Horn 	<ul style="list-style-type: none"> Generates sound when current flows. 	Switch (1)  Normally open (NO)	<ul style="list-style-type: none"> Allows or breaks current flow by opening and closing circuits. 							
Speaker 		Switch (2)  Normally closed (NC)								
Heater 	<ul style="list-style-type: none"> Generates heat when current flows. 	Harness  (Not connected)	<ul style="list-style-type: none"> Unconnected intersecting harness.  <ul style="list-style-type: none"> Connected intersecting harness. 							
Speed sensor 		<ul style="list-style-type: none"> Movement of magnet in speedometer turns contact within sensor on and off. 		 (Connected)						
Ignition switch 				<ul style="list-style-type: none"> Turning ignition key switches circuit to operate various component. 						
Relay (1)  Normally open (NO)	<ul style="list-style-type: none"> Current flowing through coil produces electromagnetic force causing contact to open or close. <table border="1" style="width: 100%; border-collapse: collapse; text-align: center;"> <thead> <tr> <th></th> <th>No current to coil</th> <th>Current to coil</th> </tr> </thead> <tbody> <tr> <td>Normally open relay (NO)</td> <td> No flow</td> <td> Flow</td> </tr> <tr> <td>Normally closed relay (NC)</td> <td> Flow</td> <td> No flow</td> </tr> </tbody> </table>		No current to coil		Current to coil	Normally open relay (NO)	 No flow	 Flow	Normally closed relay (NC)	 Flow
		No current to coil	Current to coil							
Normally open relay (NO)	 No flow	 Flow								
Normally closed relay (NC)	 Flow	 No flow								
Relay (2)  Normally closed (NC)										
Sensor (variable) 	<ul style="list-style-type: none"> Resistance changes with other components operation. 	Diode 	<ul style="list-style-type: none"> Known as a semiconductor rectifier, the diode allows current flow in one direction only. <p style="font-size: small;">Cathode (K) —> Anode (A) ← Flow of electric current</p> <p style="font-size: x-small;">K —> A K —> A K —> A</p>							
Sensor (thermistor) 		<ul style="list-style-type: none"> Resistance changes with temperature. 		Light-emitting diode (LED) 	<ul style="list-style-type: none"> A diode that lights when current flows. Unlike ordinary bulbs, the diode does not generate heat when lit. <p style="font-size: small;">Cathode (K) —> Anode (A)</p>  <p style="font-size: x-small;">Flow of current</p>					
Capacitor 				<ul style="list-style-type: none"> Component that temporarily stores electrical charge. 		Reference diode (Zener diode) 	<ul style="list-style-type: none"> Allows current to flow in one direction up to a certain voltage; allows current to flow in the other direction once that voltage is exceeded. 			
Solenoid 		<ul style="list-style-type: none"> Current flowing through coil generates electromagnetic force to operate plungers. 								

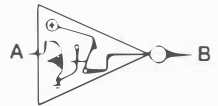
Logic symbols

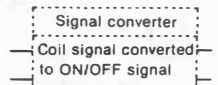
Types of logic symbols	Operation	Expressing output	Simple relay circuits
<p>OR</p> 	Input to A or B will produce output at C.	Low electrical potential (L) at A and B → no output (L) at C High electrical potential (H) at A or B → output (H) at C	
<p>AND</p> 	Input to A and B will produce output at C.	High electrical potential (H) at A and B → output (H) at C Low electrical potential (L) at A or B → no output (L) at C	
<p>INV</p> 	No input to A will produce an output at B. An input to A will not produce an output at B.	Low electrical potential (L) at A → no ground (H) B High electrical potential (H) at A → grounds (L) B	
<p>PROCESS</p> 	Simplified representation of complex functions within circuit describes main function. 1. Signal detector for engine control unit, cooling unit, and tachometer. 2. Signal converter for turn and hazard flasher unit and igniter unit.		<p>(Examples) igniters</p> 

Abbreviations used in this booklet

3GR Third Gear	ECM Engine Control Module	MTX Manual Transaxle
4GR Fourth Gear	ECPS Electronically Controlled Power Steering	NC Normally Closed
A Ampere	ECT Engine Coolant Temperature	NO Normally Open
A/C Air Conditioning	EGR Exhaust Gas Recirculation	O2S Oxygen Sensor
A/F Air Fuel	EI Electronic Ignition	OBDD On-Board Diagnostic
A/R Auto Reverse	ELEC Electric	OFF Switch Off
AAS Autoadjusting Suspension	ELR Emergency Locking Retractor	ON Switch On
ABS Antilock Brake System	ETR Electronic Tuner	P Power
ACC Accessory	F Front	P/S Power Steering
ACV Air Control Valve	F/I Fuel Injector	PAIR Pulsed Secondary Air Injection
ADD Additional	FC Fan Control	PCM Powertrain Control Module
AIR Secondary Air Injection	FICB Fast-Idle Cam Breaker	PNP Park/Neutral Position
AIS Air Injection System	FM Frequency Modulation	PRCV Pressure Regulator Control Solenoid Valve
ALL Automatic Load Leveling	FP Fuel Pump	PRG Purge Solenoid Valve
AM Amplitude Modulation	FPR Fuel Pump Relay	PSP Power Steering Pressure
AMP Amplifier	GEN Generator	PTC Positive Temperature Coefficient Heater
ANT Antenna	GND Ground	QSS Quick-Start System
AP Accelerator Pedal	H/D Heater/Defroster	R Rear
AS Autostop	HEAT Heater	REC Recirculation
ASV Air Supply Valve	HEI High-Energy Ignition	RF Right Front
AT Automatic transmission	HI High	RH Right Hand
ATX Automatic Transaxle	HO2S Heated Oxygen Sensor	RPM Engine Speed
B+ Battery Positive Voltage	IAC Idle Air Control	RR Rear Right
BAC Bypass Air Control Valve	IAT Intake Air Temperature	SAPV Secondary Air Pulse Valve
BARO Barometric Pressure	ICM Ignition Control Module	SFI Sequential Multipoint Fuel Injection
CAC Charge Air Cooler	IG Ignition	SOL Solenoid
CARB Carburetor	ILLUMI Illumination	ST Start
CCT Circuit	INT Intermittent	SW Switch
CIGAR Cigarette	JB Joint Box	TC Turbocharger
CIS Continuous Fuel Injection System	KS Knock Sensor	TCM Transmission (Transaxle) Control Module
CKP Crankshaft Position Sensor	LCD Liquid Crystal Display	TCV Twin Scroll Turbocharger Solenoid Valve
CLS Closed Loop System	LF Left Front	TEMP Temperature
CMP Camshaft Position Sensor	LH Left Hand	TICS Triple Induction Control System
COMBI Combination	LO Low	TP Throttle Position Sensor
CON Conditioner	LR Left Rear	TR Transmission Range
CONT Control	M Motor	TR Transmission (Transaxle) Range
CPU Central Processing Unit	MAF Mass Air Flow Sensor	TWS Total Wiring System
CSD Cold Start Device	MAP Manifold Absolute Pressure	V Volt
CTP Closed Throttle Position	MFI Multipoint Fuel Injection	VAF Volume Air Flow Sensor
DEF Defroster	MID Middle	VENT Ventilation
DI Distributor Ignition	MIL Malfunction Indicator Lamp	VOL Volume
DLC Data Link Connector	MIN Minute	VR Voltage Regulator
DLI Distributorless Ignition	MIX Mixture	VRIS Variable Resonance Induction System
DOHC Double-Overhead Camshaft	MPX Multiplex	VSS Vehicle Speed Sensor
DTC Diagnostic Trouble Code(s)	MT Manual Transmission	W Watt(s)
DTM Diagnostic Test Mode	MTR Mechanical Tuning Radio	WOT Wide Open Throttle

Precautions to take when servicing an electrical system

- Note the following items when servicing the electrical system.
- Do not alter the wiring or electrical equipment in any way; this may damage the vehicle or cause a fire from short-circuiting a circuit or overloading it.

- The negative (-) battery cable must be removed first and installed last.



- Do not replace with fuses exceeding specified capacity.

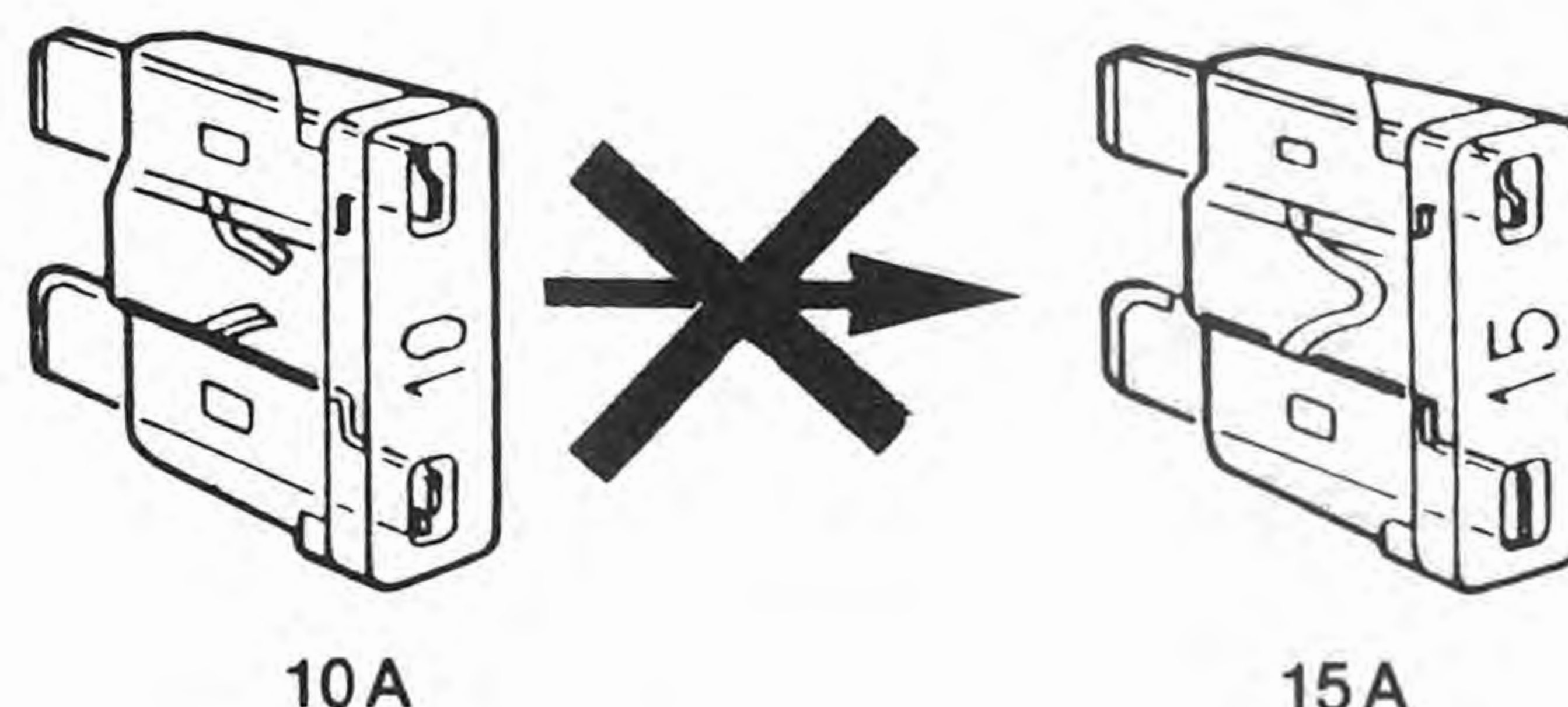

Caution

- Be sure that the ignition and other switches are off before disconnecting or connecting the battery cables. Failure to do so may damage the semiconductor components.
- Secure harnesses with provided clamps to take up slack.

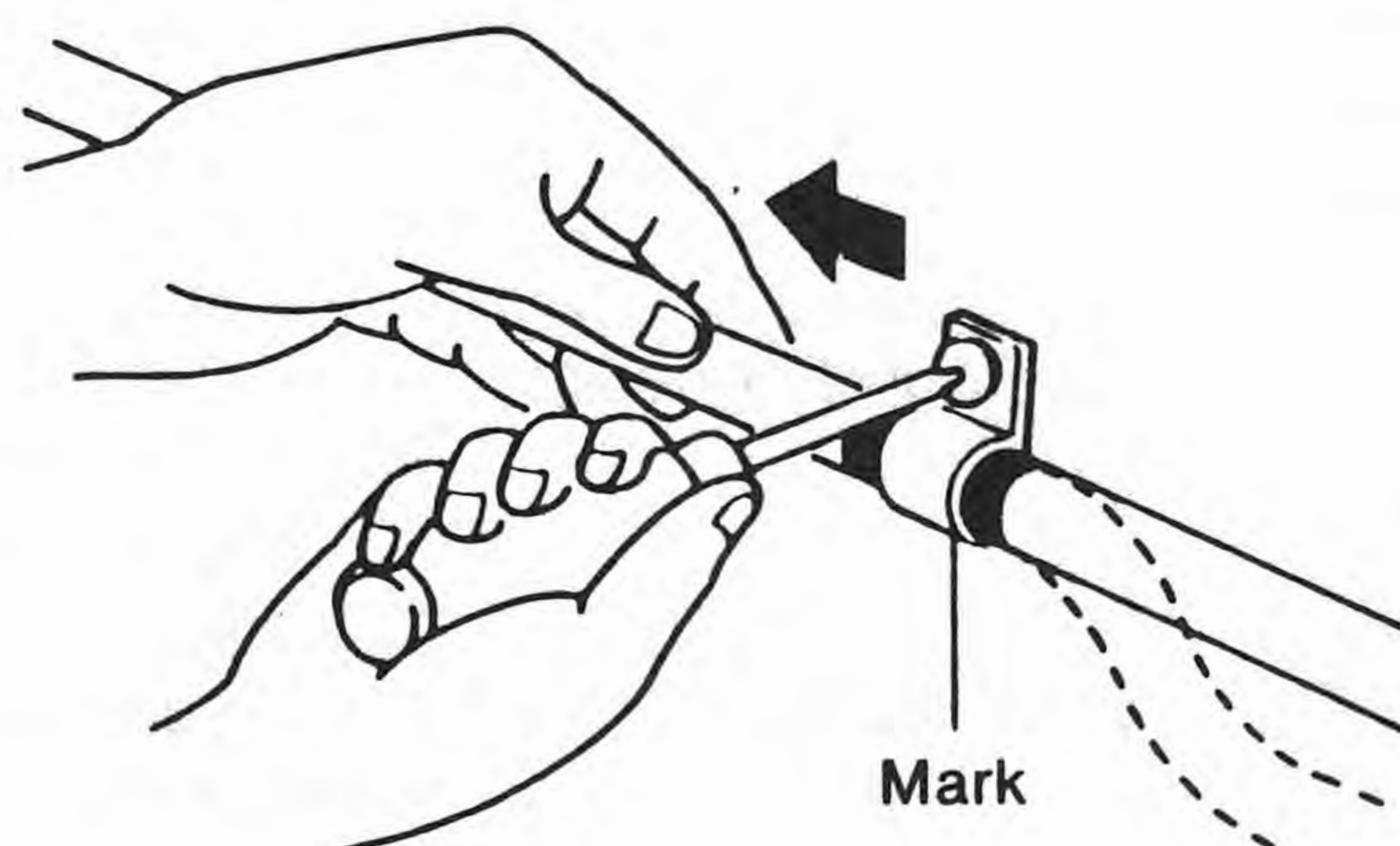

Caution

- Replacing a fuse with one of a larger capacity than designated may damage components or cause a fire.
- Tape areas of the harness that may rub or bump against sharp edges to protect it from damage.
- When mounting components, be sure the harness is not caught or damaged.

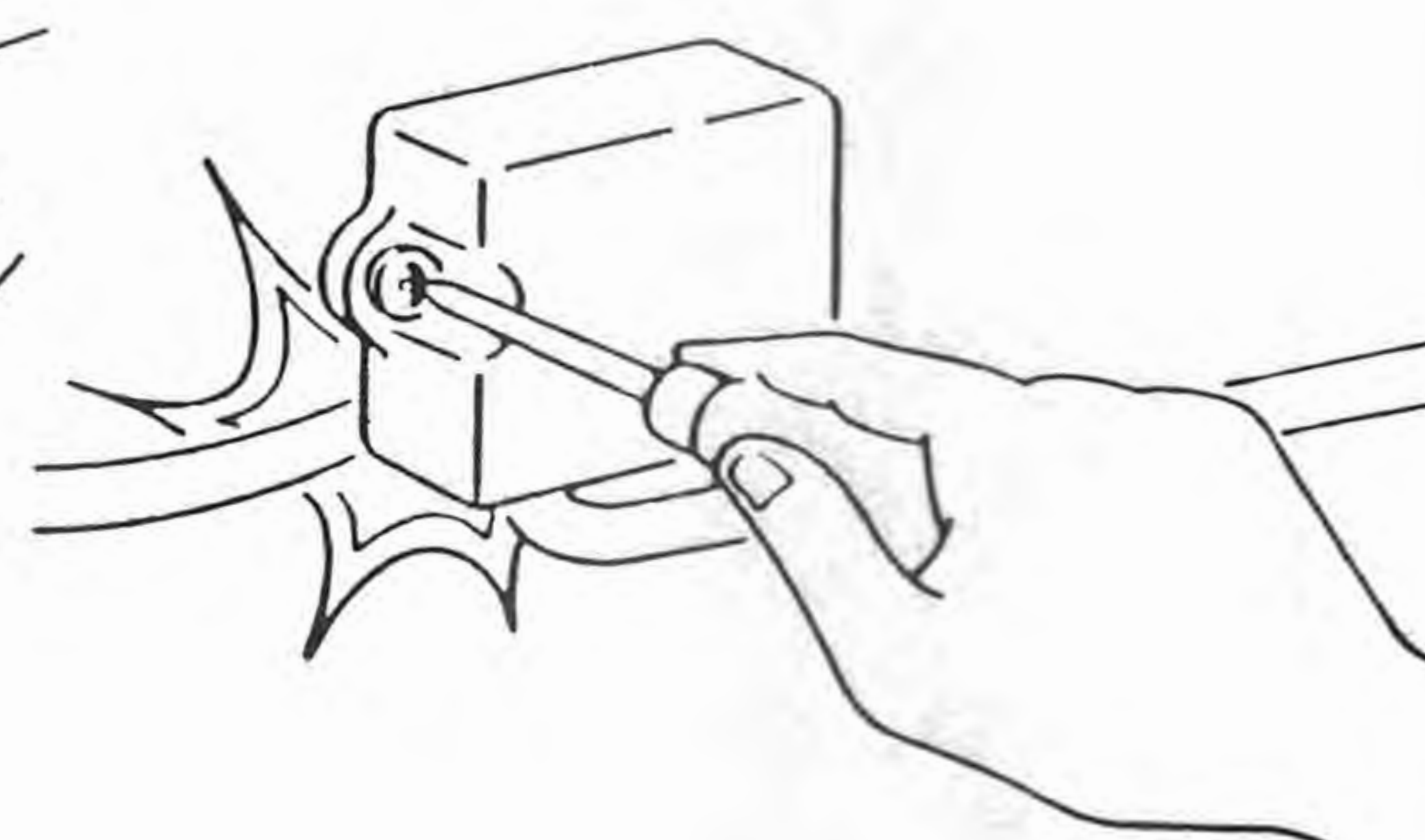
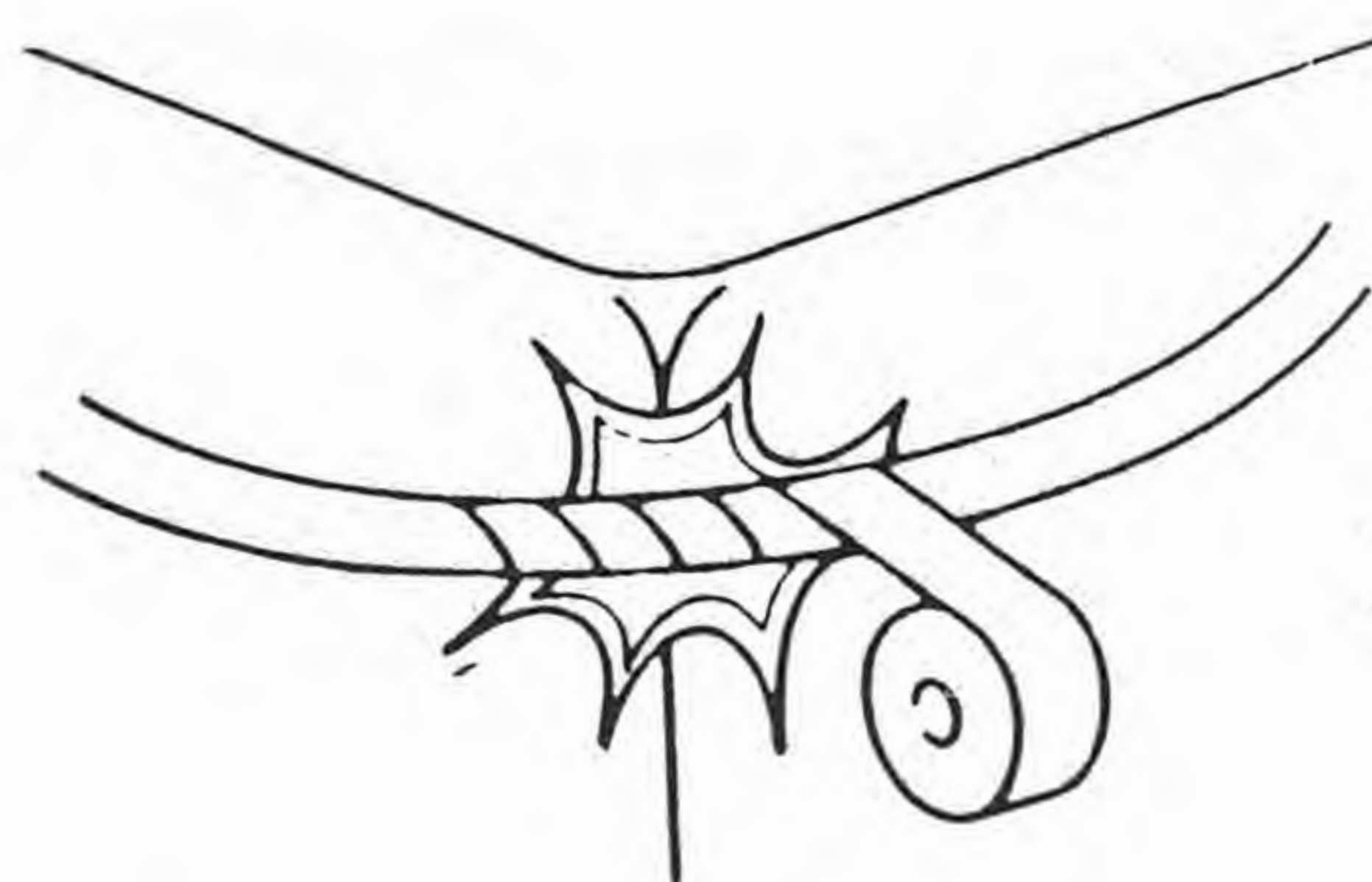

Caution

- Clamp all harnesses near vibrating components (for example, the engine) to remove slack and to prevent contact resulting from vibration.
- Do not handle electrical components roughly or drop them.





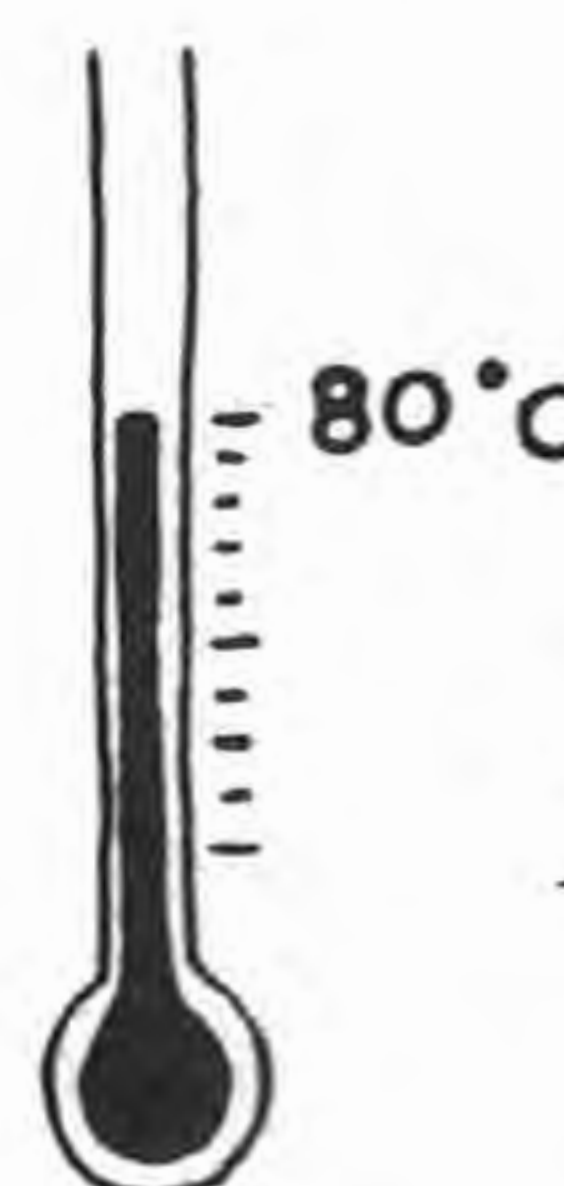









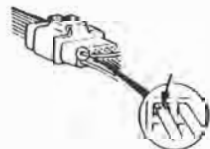
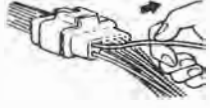
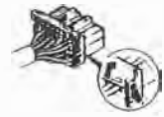
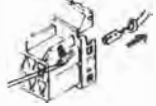



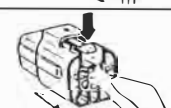

- Disconnect heat-sensitive parts (for example, relays and ECU) when performing maintenance (such as welding) where temperatures may exceed 80°C (176°F).

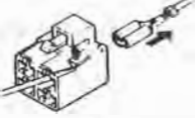



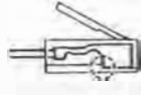

Handling connectors

Caution

- Be sure to grasp the connectors, not the wires, when disconnecting them.

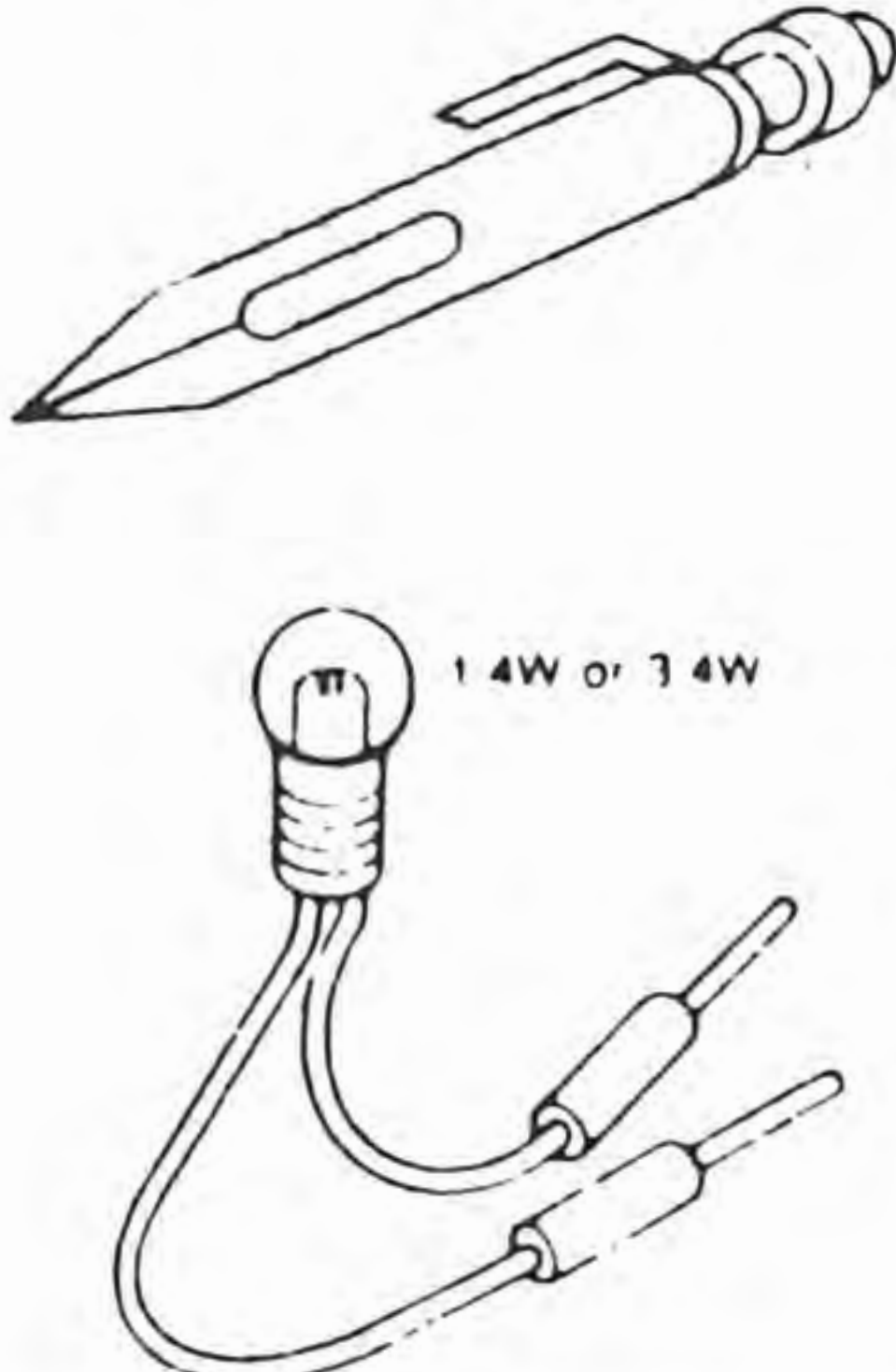
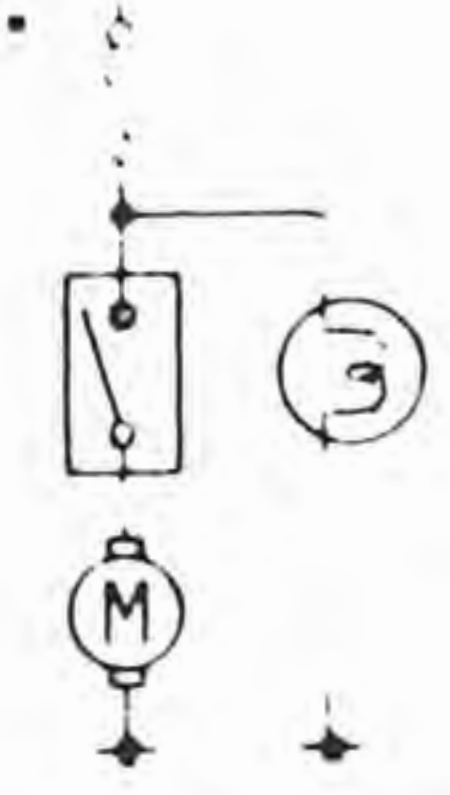
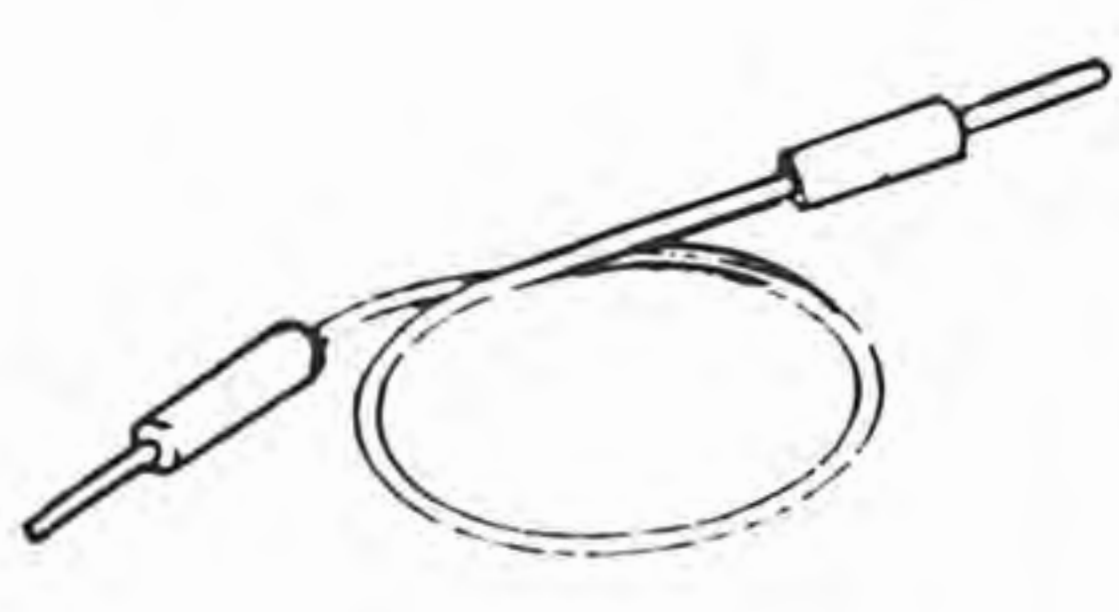
Connector removal		Checking connector contacts	Checking for loose terminals	Replacing terminal
Push type	 Remove	<p>Caution Improperly engaged connectors will cause poor terminal contact.</p>  <p>When using a matching male terminal, make sure there is no looseness in the female terminal.</p>	<p>Caution A loose terminal will cause poor terminal contact.</p>  <p>Make sure the terminals are not pushed out of the connector when engaged.</p> 	<p><CPU connector></p>  <ol style="list-style-type: none"> 1. Raise the rear cover. 2. Lift the tab with a thin piece of metal and remove the terminal. 
				
				
				
				
				
				
				
Pull-up type		<p>Pull lightly on individual wires to check that they are secured in the terminal.</p>	<p><General connector></p>  <p>Lift the tab with a thin piece of metal and remove the terminal.</p>	
				
				
				
Spring type			<p><Round connectors></p> <ol style="list-style-type: none"> 1. Raise the cover. 2. Lift the terminal to remove it. 3. Make sure the terminal is securely mounted in the connector when installing.  	
			<p><Common ground connectors></p> <ol style="list-style-type: none"> 1. Raise the cover. 2. Remove A. 3. Lift the tab with a thin piece of metal and remove the terminal.  	

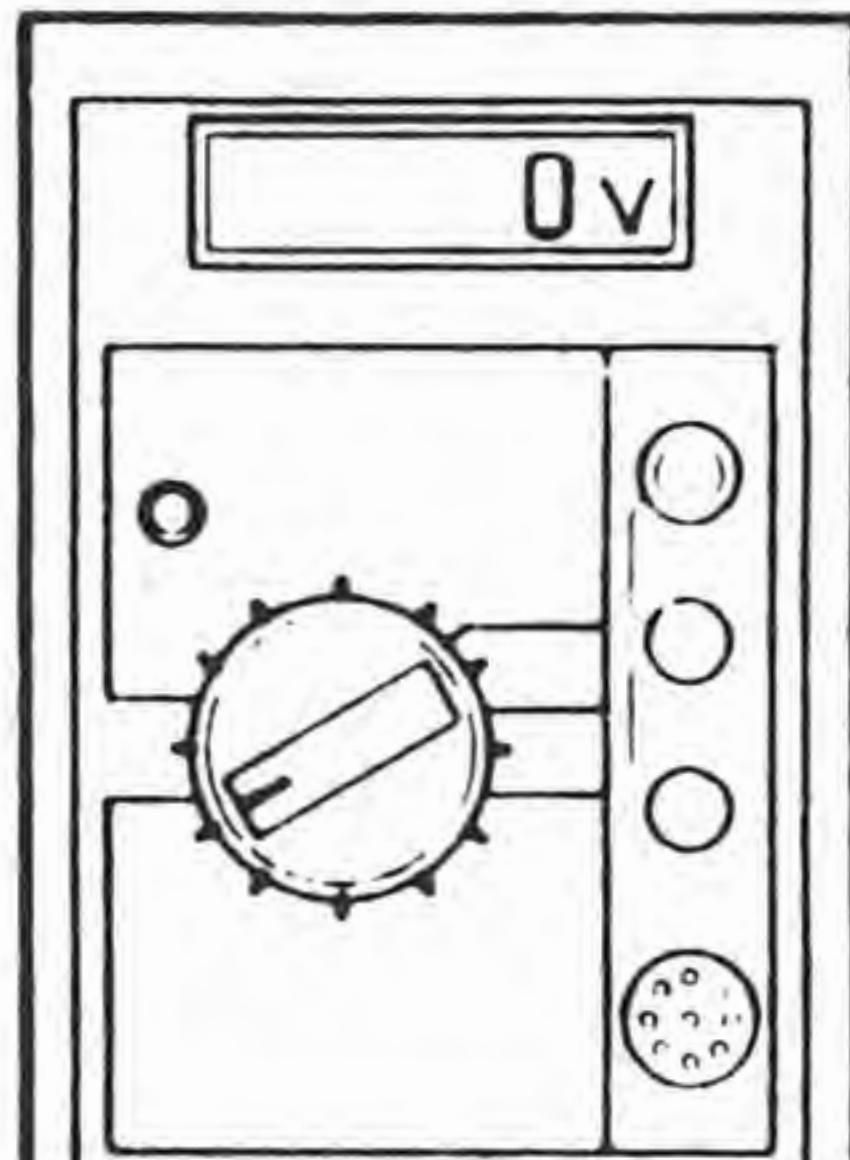
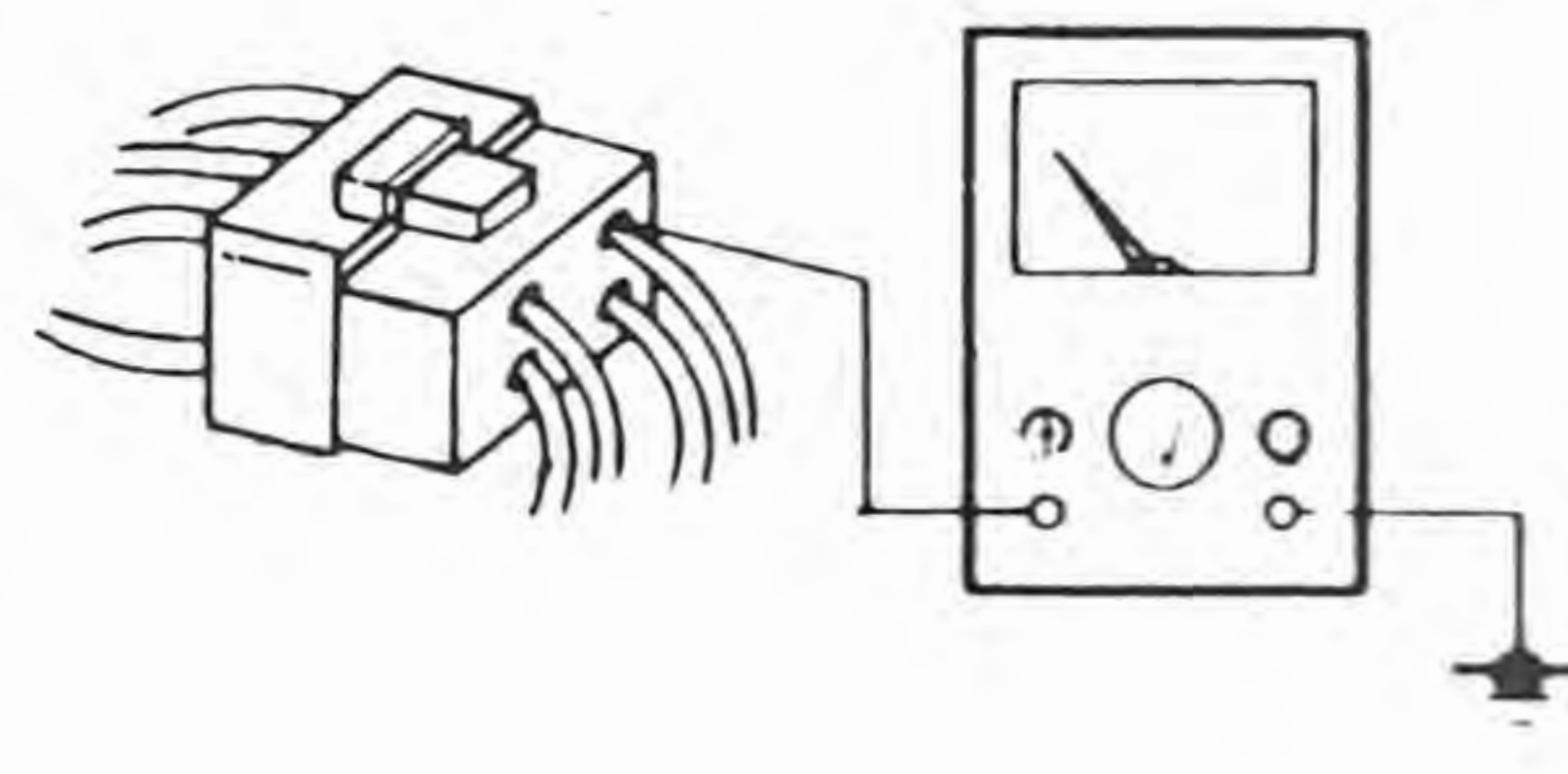
Using electrical measuring equipment

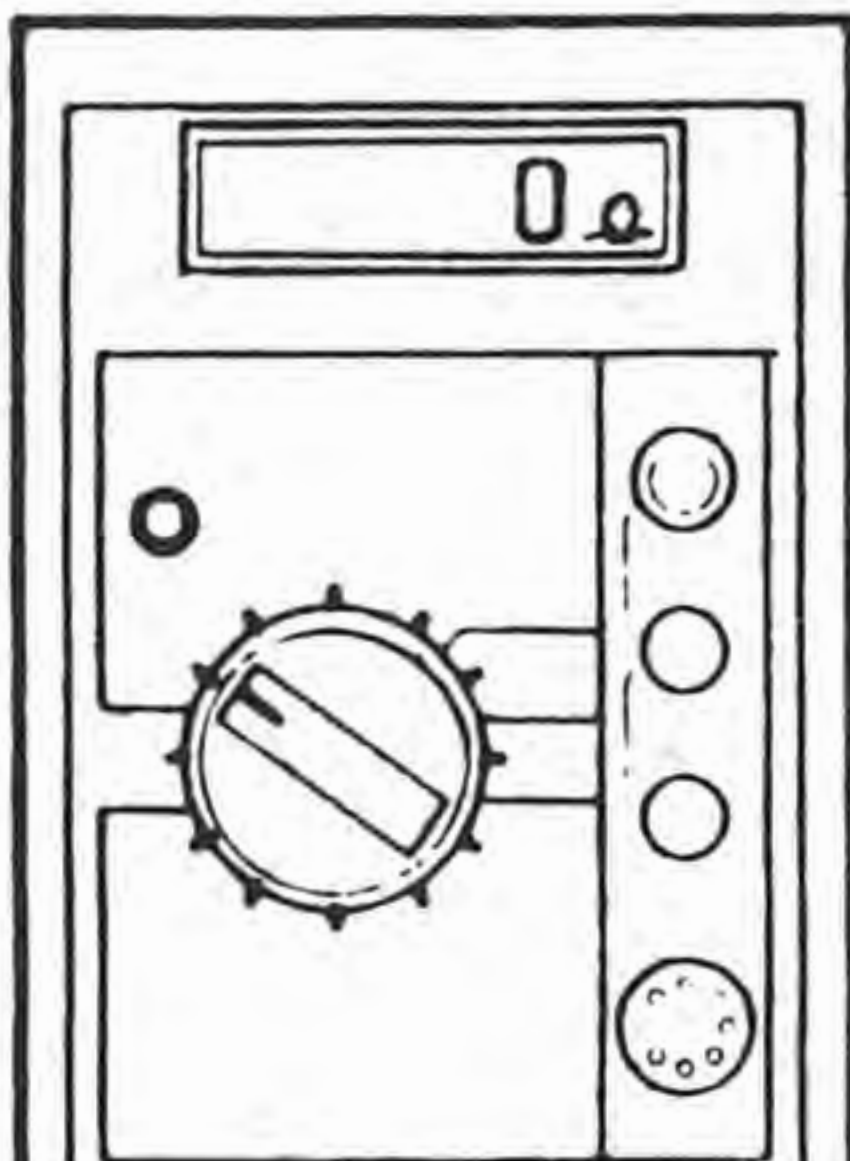
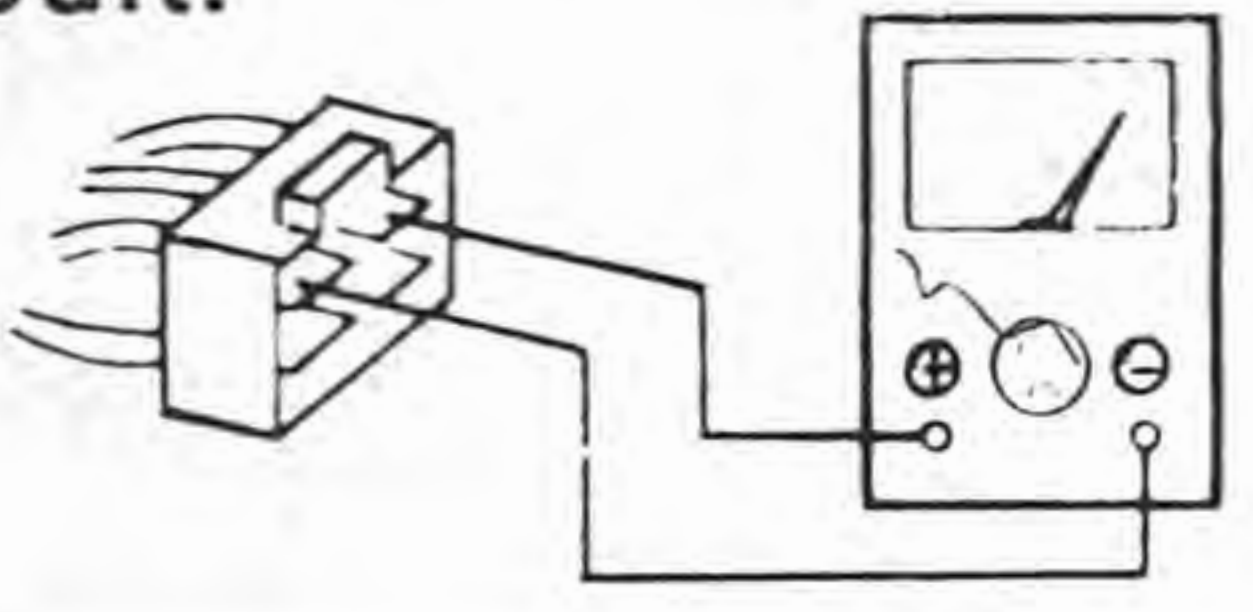
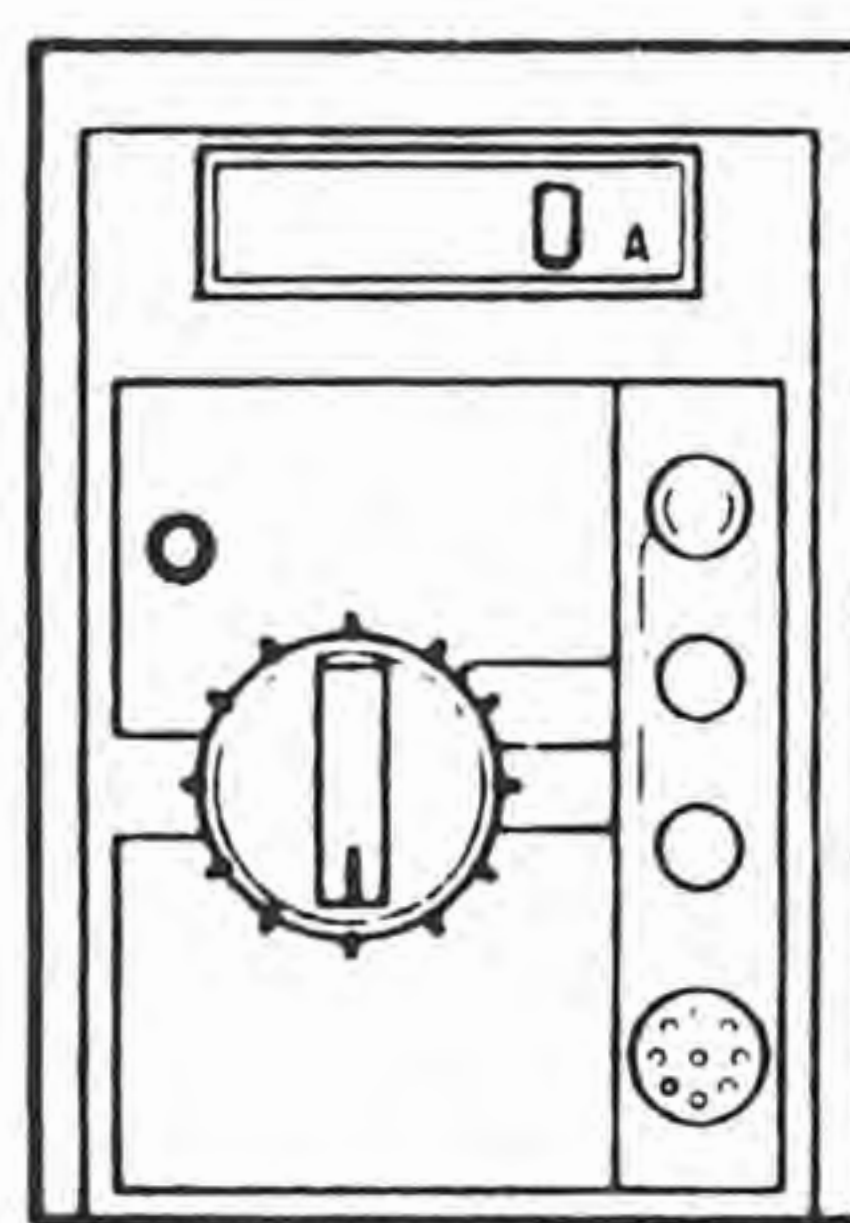
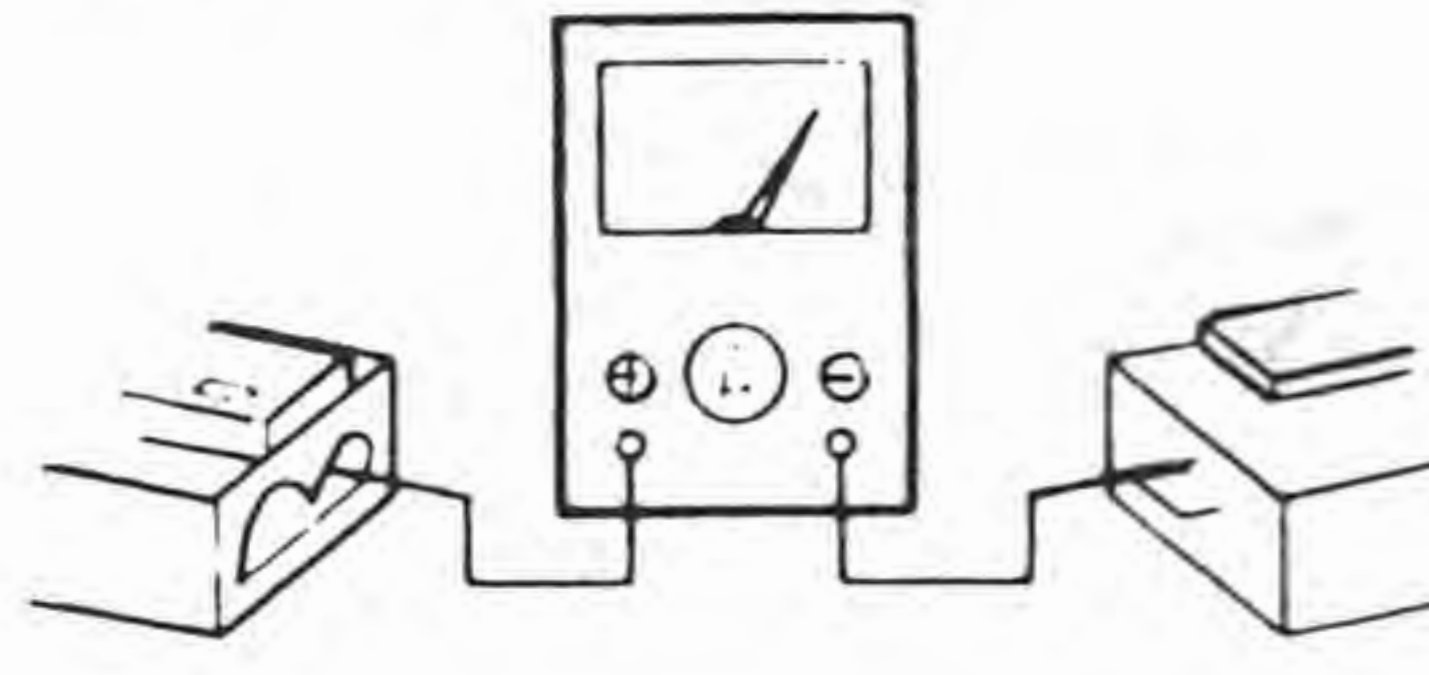
Equipment	Use	Operation	Handling precautions
Test lamp 	Test to find open or shorted circuits.	<ul style="list-style-type: none"> Connect the test lamp between the circuit being measured and a ground. The lamp will light if the circuit is energized to the point tested. 	<ul style="list-style-type: none"> Test lamps use 12V 1.4W or 3.4W bulbs or light-emitting diodes (LEDs). Using a large-capacity bulb may damage the CPU.
Jumper wire 	Used to create a temporary circuit.	<ul style="list-style-type: none"> Connect the jumper wire between the terminals of a circuit to bypass a switch. 	<ul style="list-style-type: none"> Do not connect the jumper wire from the power source line to a ground; this may cause burning or other damage to harnesses or electronic components.
Voltmeter 	Used for measuring the voltage of a circuit to locate possible opens or shorts.	<ul style="list-style-type: none"> Connect the positive (+) probe to the point where voltage is to be measured and the negative (-) probe to a ground. 	<ul style="list-style-type: none"> Connect the voltmeter in parallel with the circuit. Set the range to the desired voltage. Use the service hole when measuring the voltage at the diagnosis connector. Tie a thin wire to the positive (+) probe to access narrow terminals. 
Ohmmeter 	Used to find opens and shorts in the circuit, to confirm continuity and to measure resistance.	<ul style="list-style-type: none"> Zero the ohmmeter. Verify that voltage is not applied to the circuit. Connect the probes between two points in a circuit. 	<ul style="list-style-type: none"> Zero the meter after switching to the measuring range. Before using the ohmmeter, make sure the ignition switch is off or the negative (-) battery cable is disconnected to prevent burning or otherwise damaging the ohmmeter.
Ammeter 	Used to check alternator output, current supplied to the starter, and dark current within a circuit. Note Dark current is the constant flow of current while the ignition switch is OFF.	<ul style="list-style-type: none"> Connect the ammeter in series with the circuit by touching the positive (+) probe to the power-side terminal and the negative (-) probe to the ground-side terminal. 	<ul style="list-style-type: none"> Set the range to the desired amperage. Connect the ammeter in series with the circuit. The ammeter may be burned or otherwise damaged if it is connected in parallel.

Measuring voltage

Checks

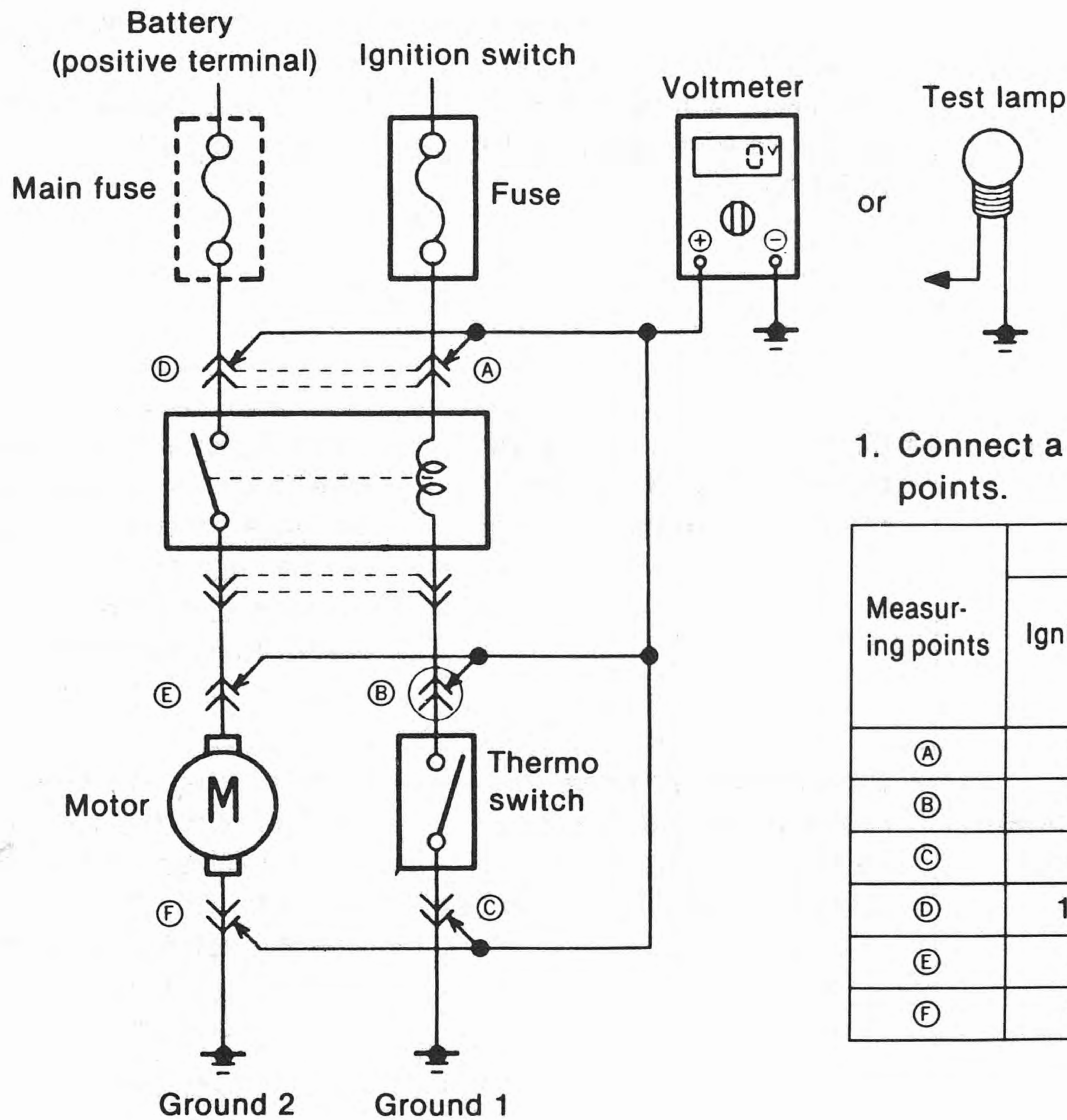

1. Connect a voltmeter or test lamp to the measuring points.

Measuring points	Circuit operation (normal)			
	Ignition switch: OFF	Ignition switch: ON		
		Thermo switch: OFF	Thermo switch: ON	
(A)	0V ×	12V ○	12V ○	
(B)	0V ×	12V ○	0V ×	
(C)	0V ×	0V ×	0V ×	
(D)	12V ○	12V ○	12V ○	
(E)	0V ×	0V ×	12V ○	
(F)	0V ×	0V ×	0V ×	

○ : Test lamp ON
× : Test lamp OFF

Precautions during checks

Measuring voltage of connectors

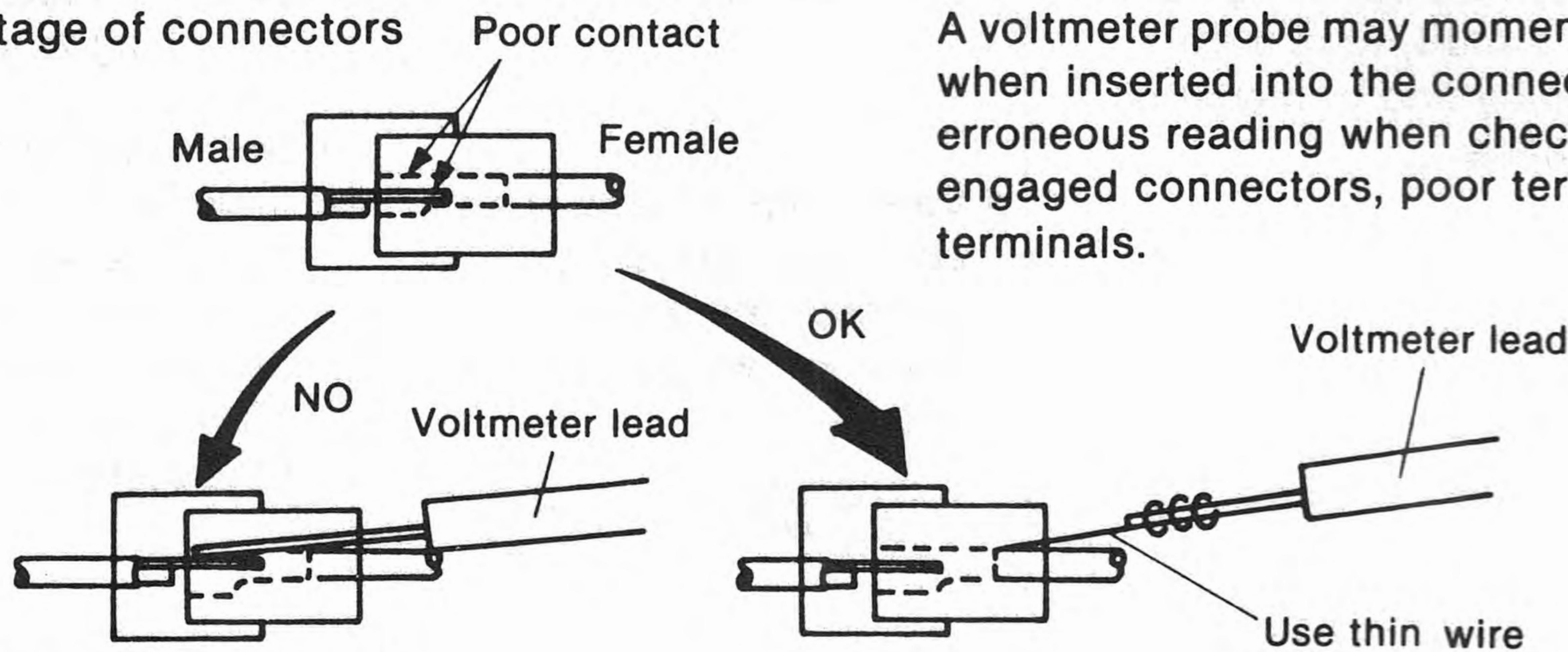

A voltmeter probe may momentarily connect a terminal when inserted into the connector and give an erroneous reading when checking for improperly engaged connectors, poor terminal contacts, or loose terminals.

Measuring voltage of ground unit

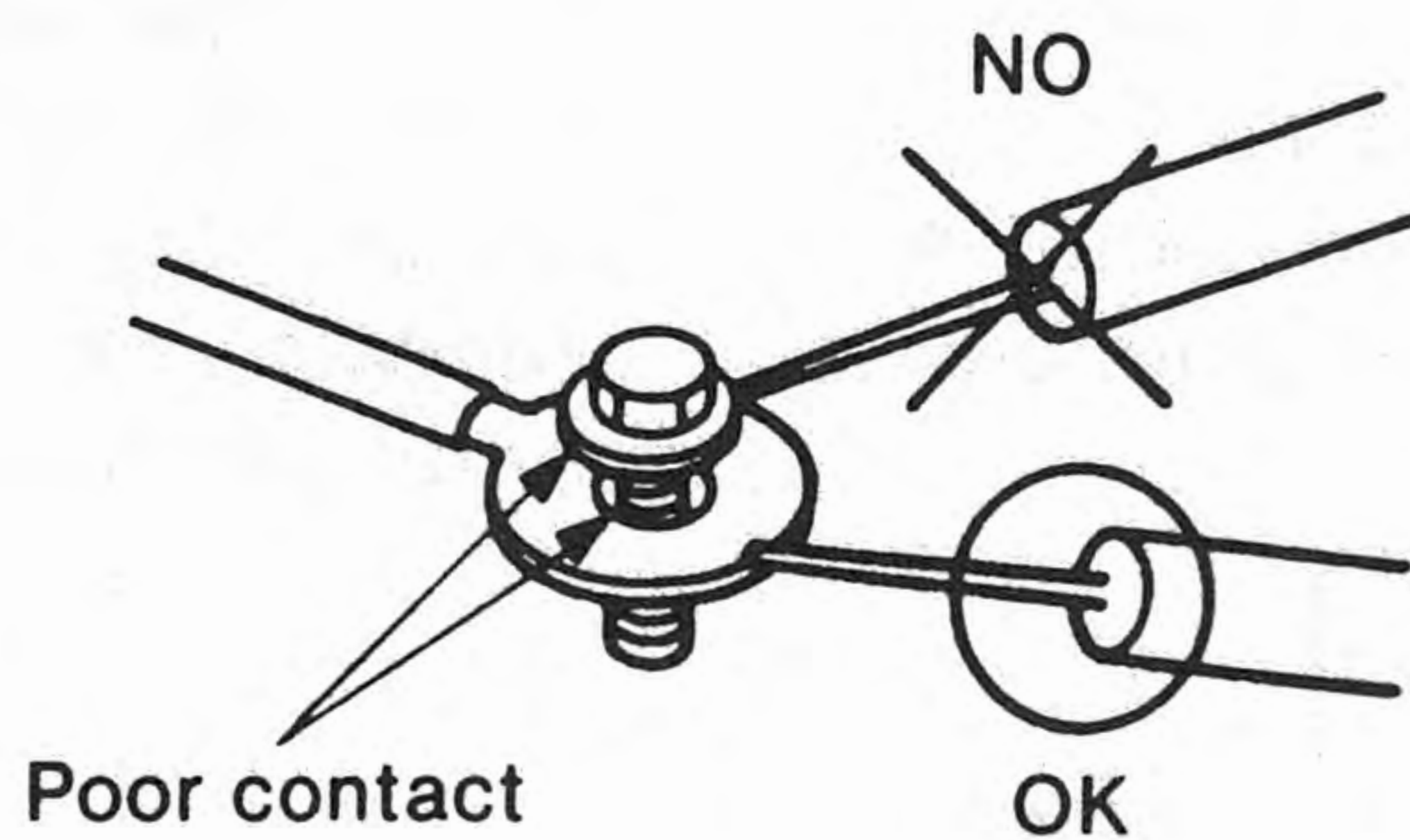

Touch the voltmeter probe to the ground wire when checking the ground circuit.

Measuring continuity/resistance

Checking switches

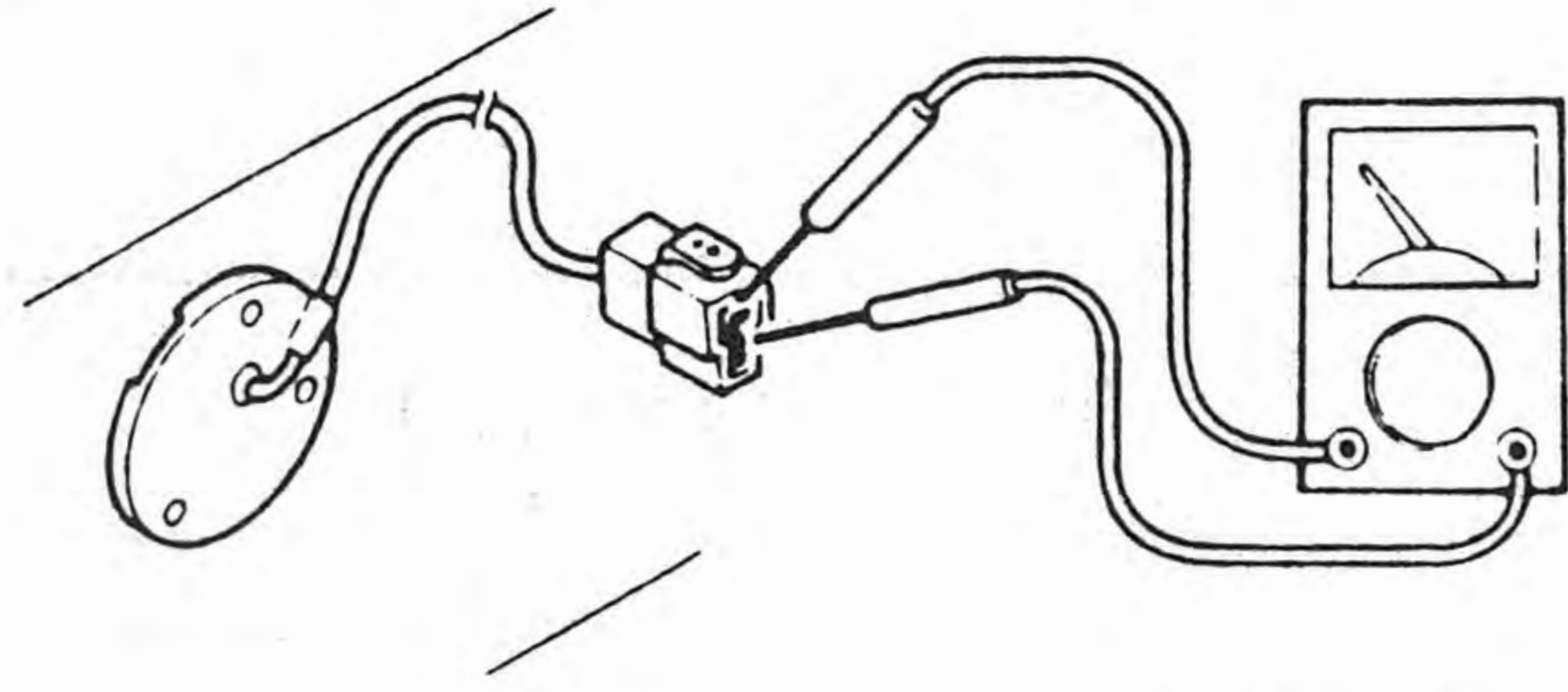

Touch the ohmmeter probes to the switch terminals to check continuity.

Caution
Verify the operating state of the switch before checking continuity because readings vary accordingly.

Checking diodes

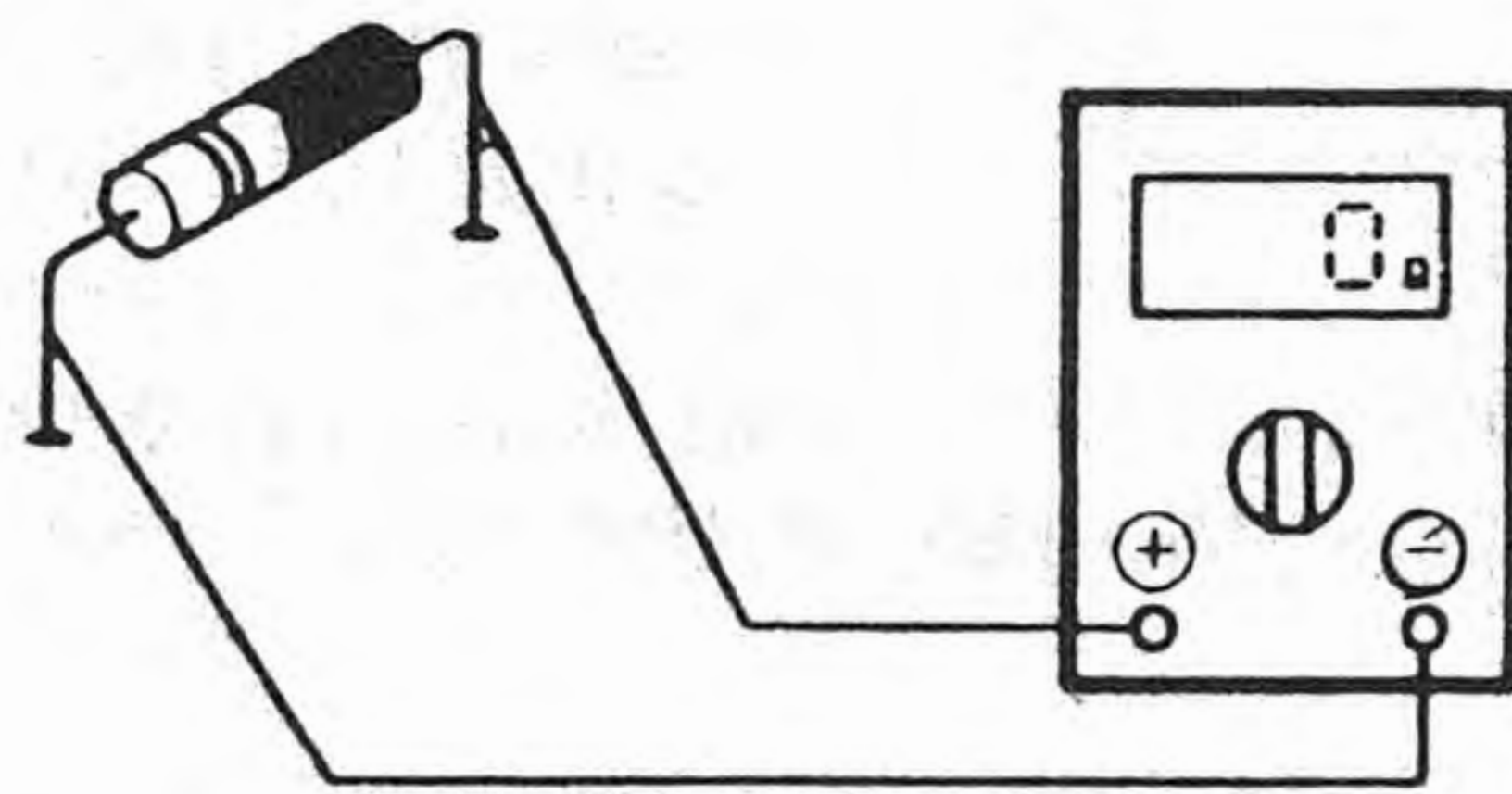

Continuity is checked according to the direction of the positive (+) and negative (-) probes of the ohmmeter in the circuit containing the diode.

Connection	Continuity
	Yes
	No

Note

The negative (-) probe of the ohmmeter is connected to the positive terminal of the internal ohmmeter battery, the positive (+) probe to the negative terminal of the battery.

Checking sensors and solenoid valves

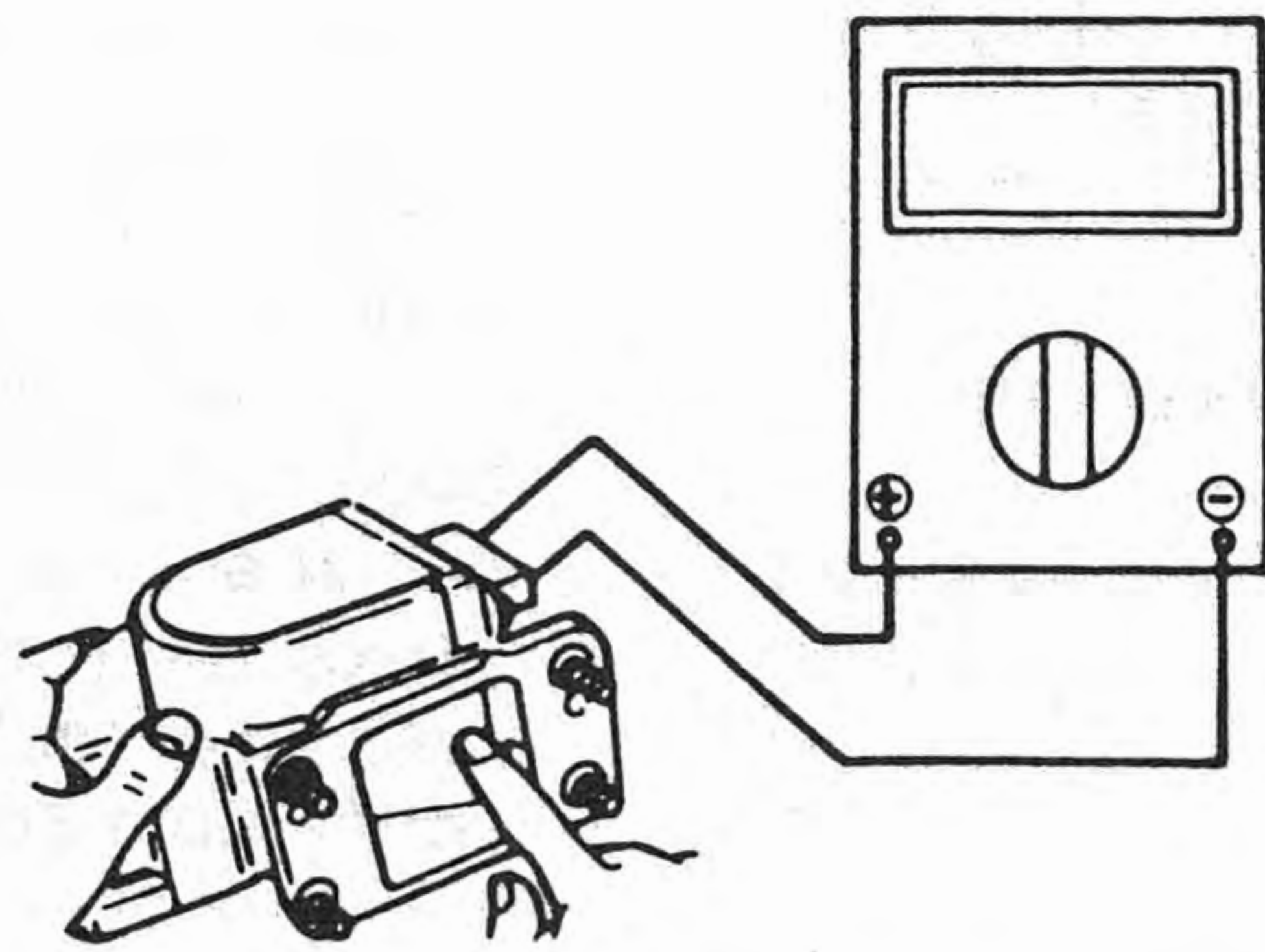

Connect the ohmmeter probes to the sensor or solenoid valve terminals to check resistance.

Caution
Verify the operating state of the sensor before checking resistance because readings vary accordingly.

Checking condensers

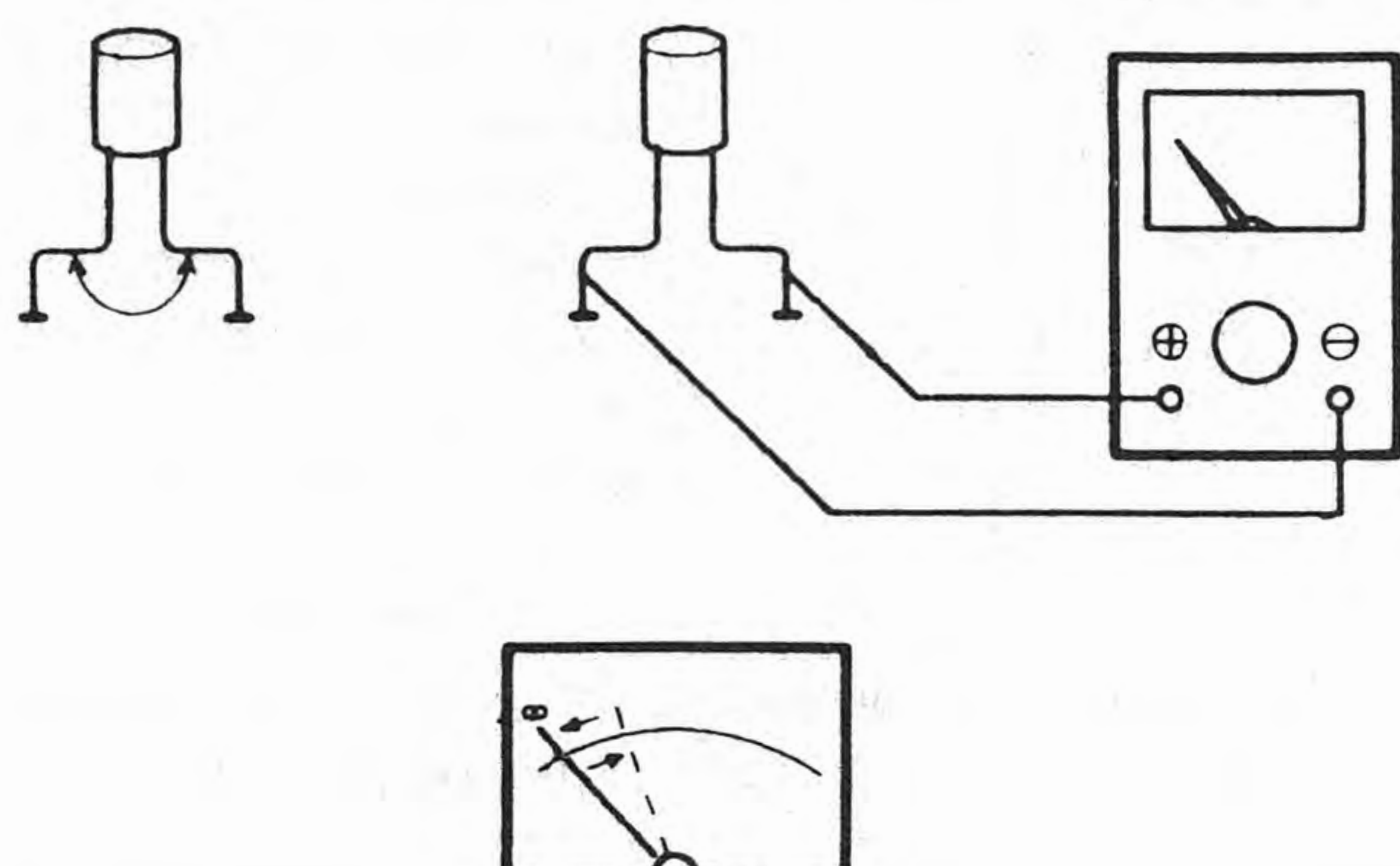

1. Short between the terminals with a jumper wire to discharge the capacitor.
2. Set the ohmmeter range to $\times 10k\Omega$ and connect it to the capacitor terminals.
3. The capacitor is good if the needle of the ohmmeter swings once and returns to its original position.

Finding short circuits

Shorts occur between the power (positive) and ground (negative) sides of a circuit. Therefore, finding a short circuit requires determining how the circuit is routed.

Circuits not connected to control unit

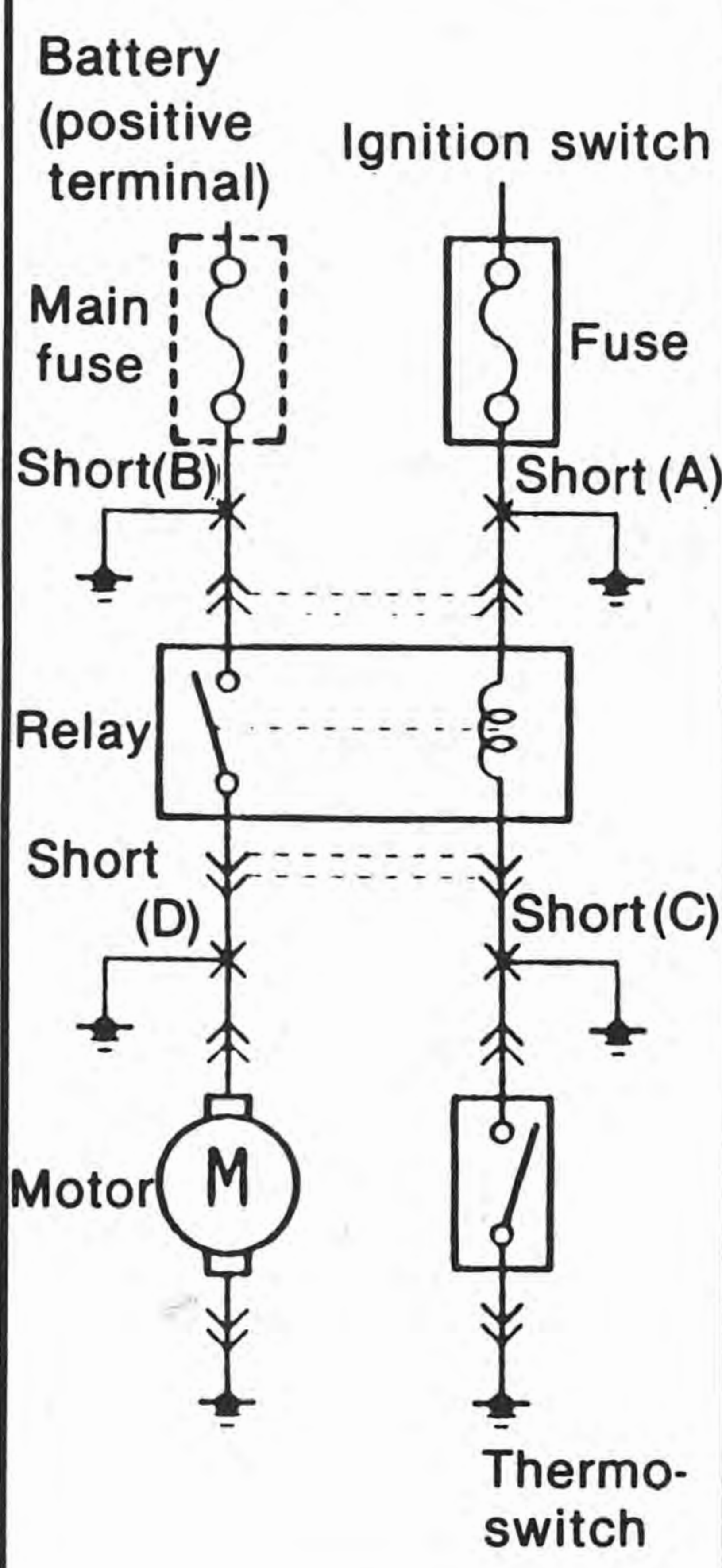
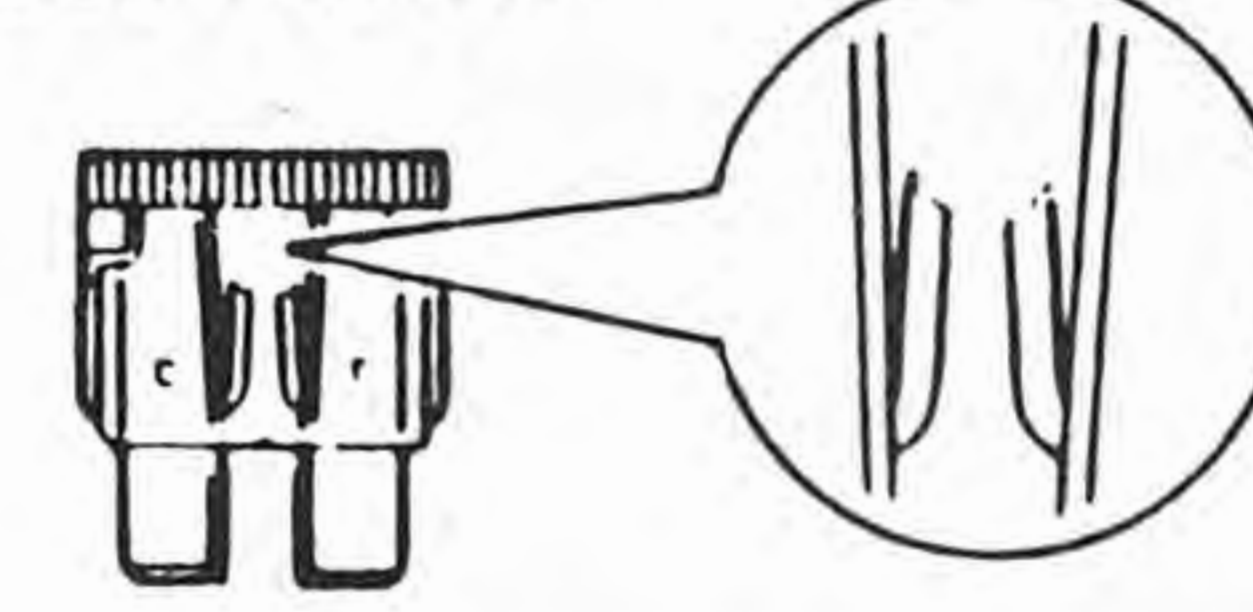
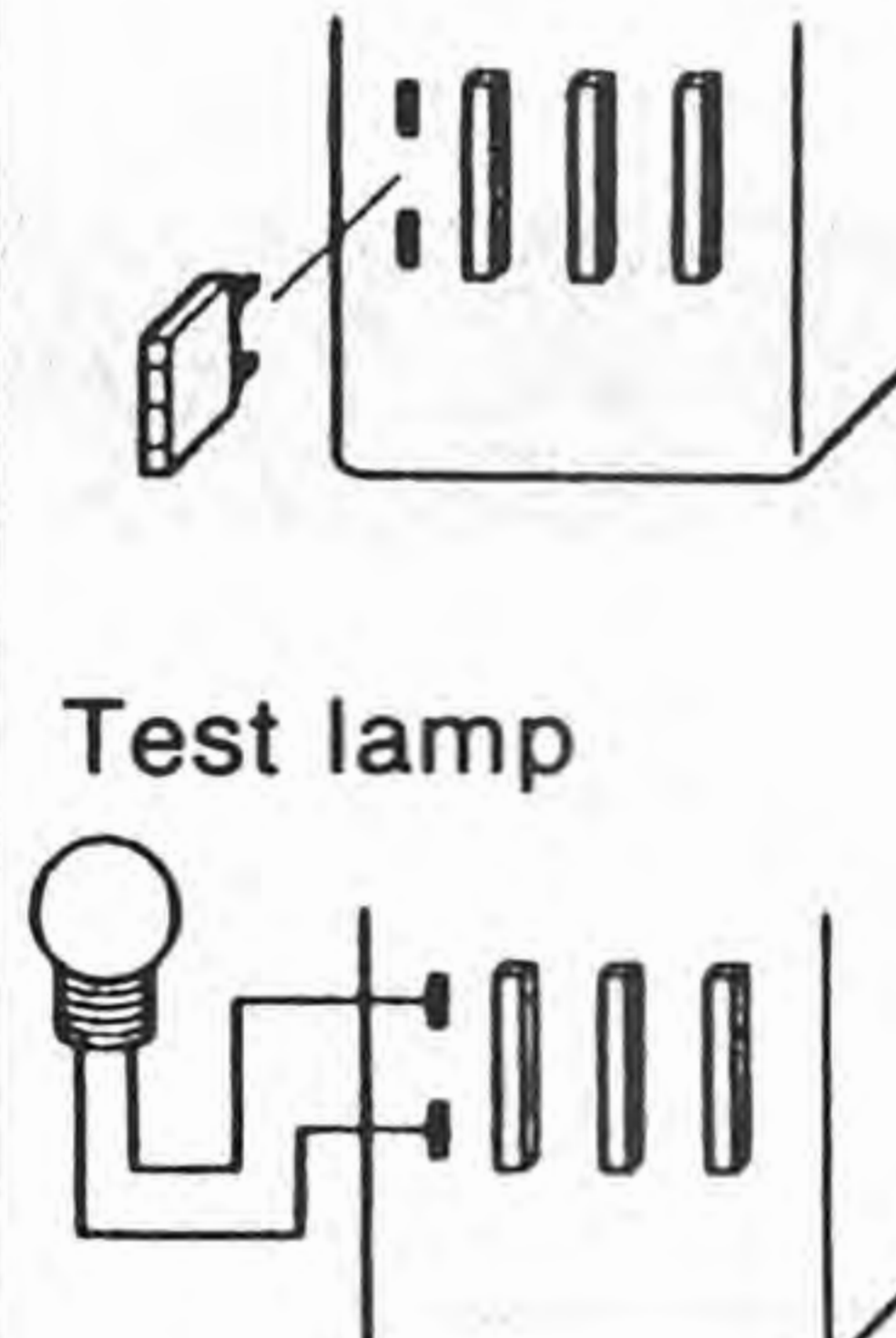
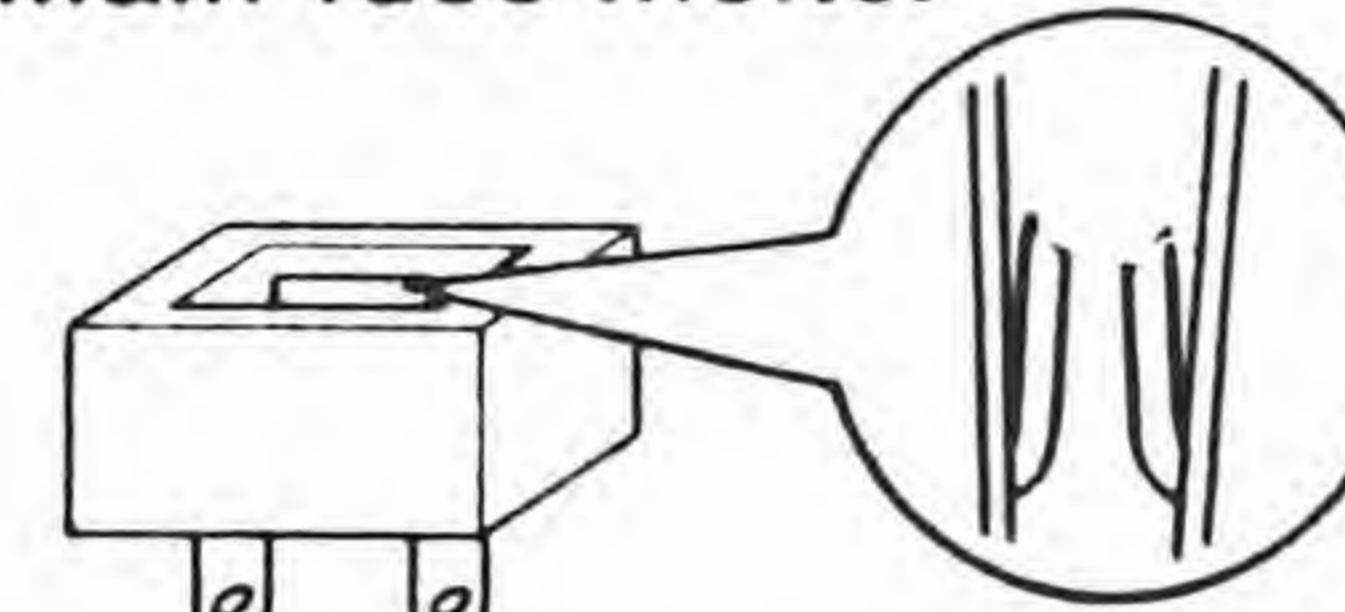



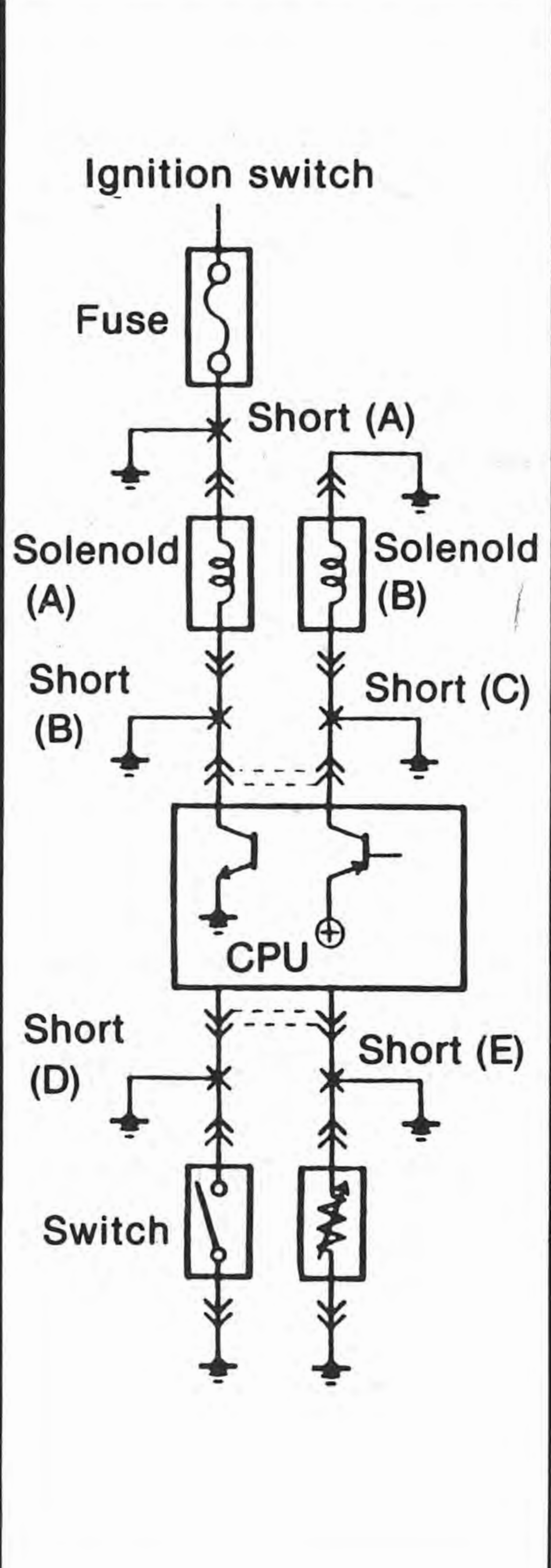
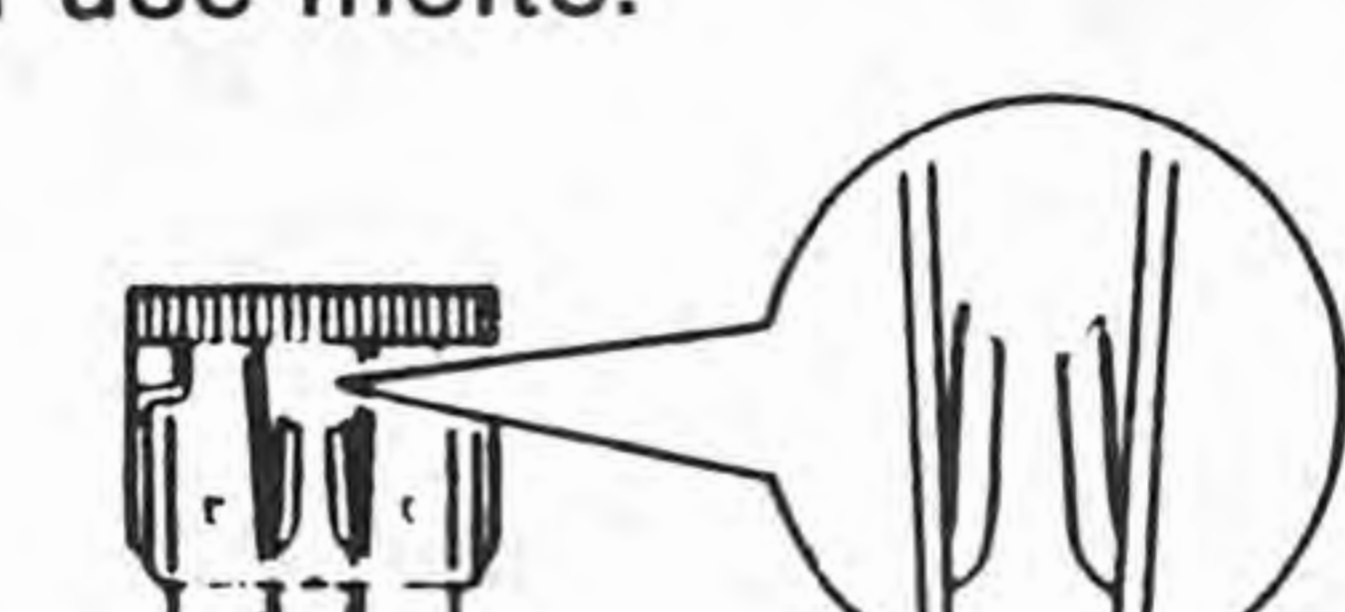
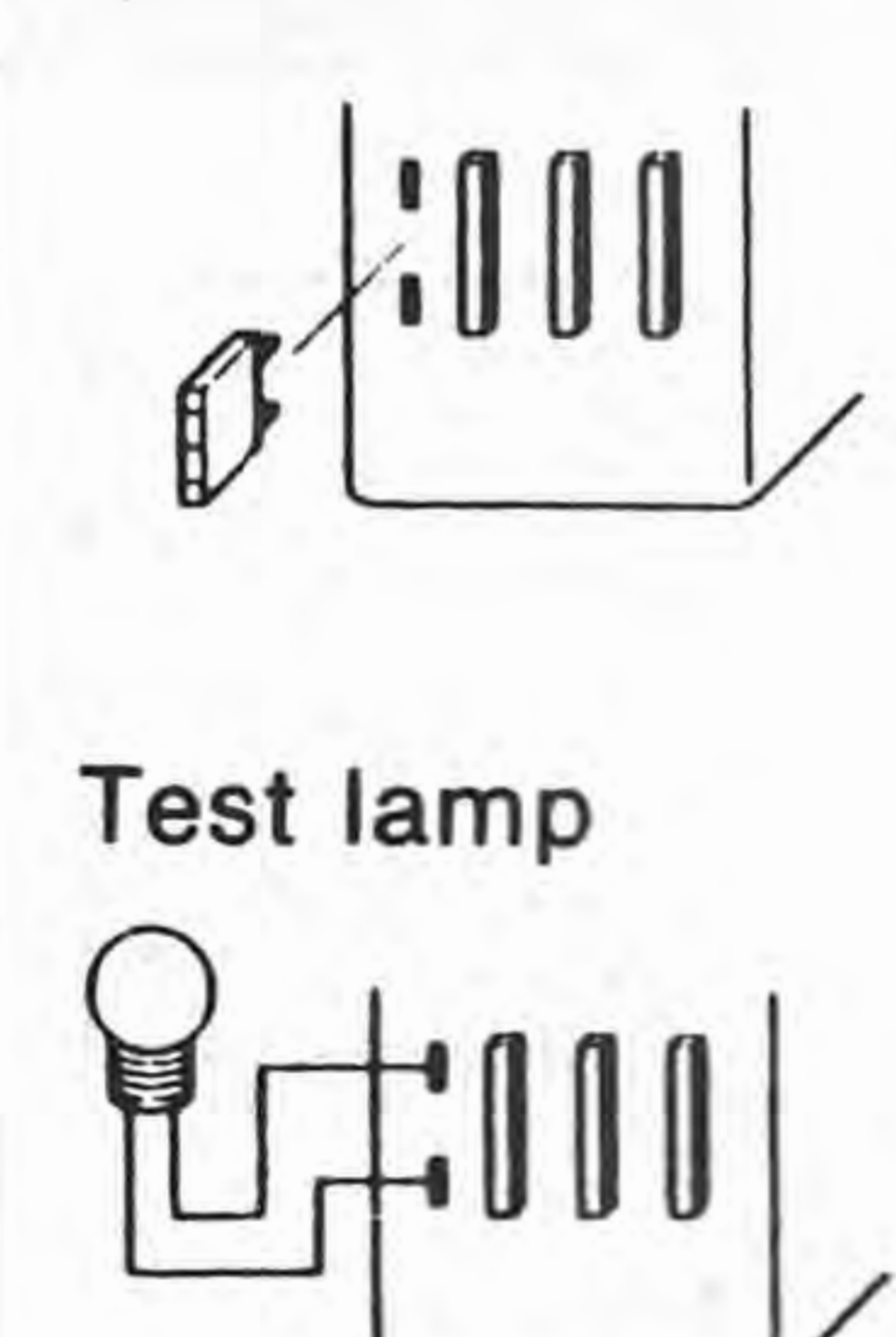





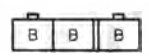
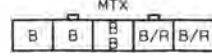
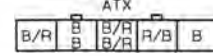
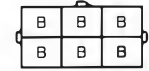
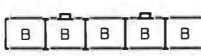









	Examples		Finding short circuit
	Short location	Symptom	
Short (A)	<ul style="list-style-type: none"> Fuse melts. 	 <ol style="list-style-type: none"> Remove the fuse and main fuse of the circuit. Disconnect all connectors of electrical components in the circuit. Attach a voltmeter or test lamp to the fuse box and reconnect each connector, beginning nearest the power source. Check the voltmeter reading or test lamp as the connectors are connected. <div style="border: 1px solid black; padding: 5px; margin-top: 10px;"> A short has occurred where the voltmeter reading changes or the test lamp comes on. </div>	
Short (B)	<ul style="list-style-type: none"> Main fuse melts. 		
Short (C)	<ul style="list-style-type: none"> The motor operates regardless of whether the thermostatic switch is ON or OFF when the ignition switch is ON. The fuse is not melted. 		
Short (D)	<ul style="list-style-type: none"> The main fuse melts when the ignition switch and thermostatic switch are ON and the relay is operating. 		

Circuits connected to control unit

	Examples		Finding short circuit
	Short location	Symptom	
Short (A)	<ul style="list-style-type: none"> Fuse melts. 	 <ol style="list-style-type: none"> Remove the fuse and main fuse of the circuit. Disconnect all connectors of electrical components in the circuit. Attach a voltmeter or test lamp to the fuse box and reconnect each connector, beginning nearest to the power source. Check the voltmeter reading or test lamp as the connectors are connected. <div style="border: 1px solid black; padding: 5px; margin-top: 10px;"> A short has occurred where the voltmeter reading changes or the test lamp comes on. </div>	
Short (B)	<ul style="list-style-type: none"> Solenoid A operates when the ignition switch is ON. 		
Short (C)	<ul style="list-style-type: none"> The CPU transistor burns out when the ignition switch is turned ON. 		
Short (D)	<ul style="list-style-type: none"> The CPU thinks the switch is ON because the same conditions exist as when the switch is ON. 		
Short (E)	<ul style="list-style-type: none"> The CPU senses the sensor to be 0Ω because the same conditions exist as when the resistance value is 0Ω. The CPU equipped with the self-diagnosis function outputs the code. 		

Z WIRING DIAGRAM

Y-1 FS ■ GROUND POINTS

<p>JC-01 JOINT CONNECTOR (F)</p> 	<p>JC-02 JOINT CONNECTOR (I)</p> 	<p>JC-03 JOINT CONNECTOR (EM)</p> <div style="display: flex; justify-content: space-around;"> <div style="text-align: center;"> <p>MTX</p>  </div> <div style="text-align: center;"> <p>ATX</p>  </div> </div>			<p>JC-04 JOINT CONNECTOR (R)</p> 	<p>JC-05 JOINT CONNECTOR (R)</p> 
<p>JC-06 JOINT CONNECTOR (AB)</p> 	<p>①   B</p>	<p>⑬   B</p>	<p>②   B</p>	<p>⑤   B/L</p>	<p>⑦   MTX  B/H, B/R</p> <p>ATX  B</p>	
<p>⑧   B/G, B/G</p>	<p>⑭   B/Y</p>	<p>⑨   B, B</p>				

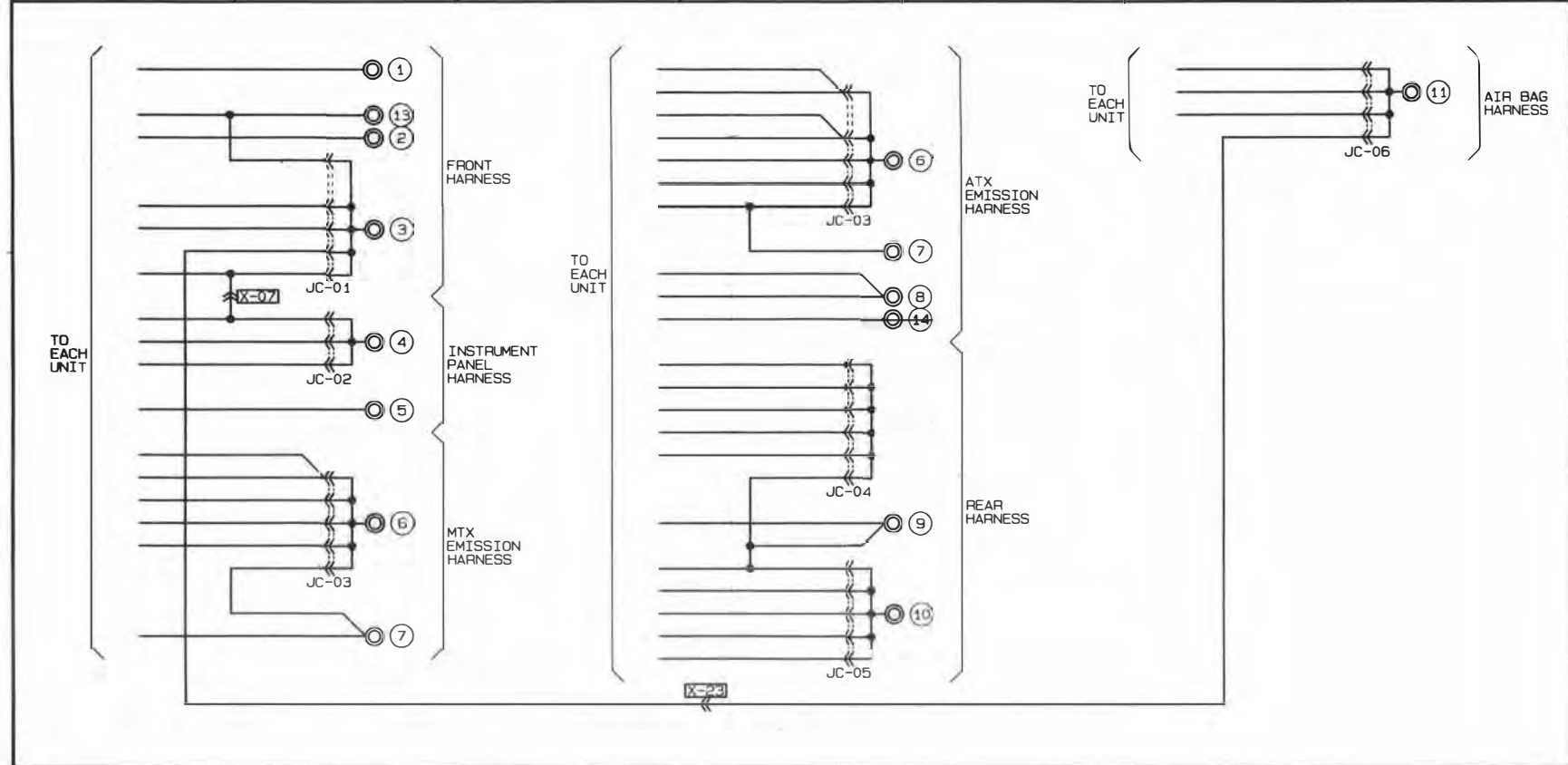

Y-1

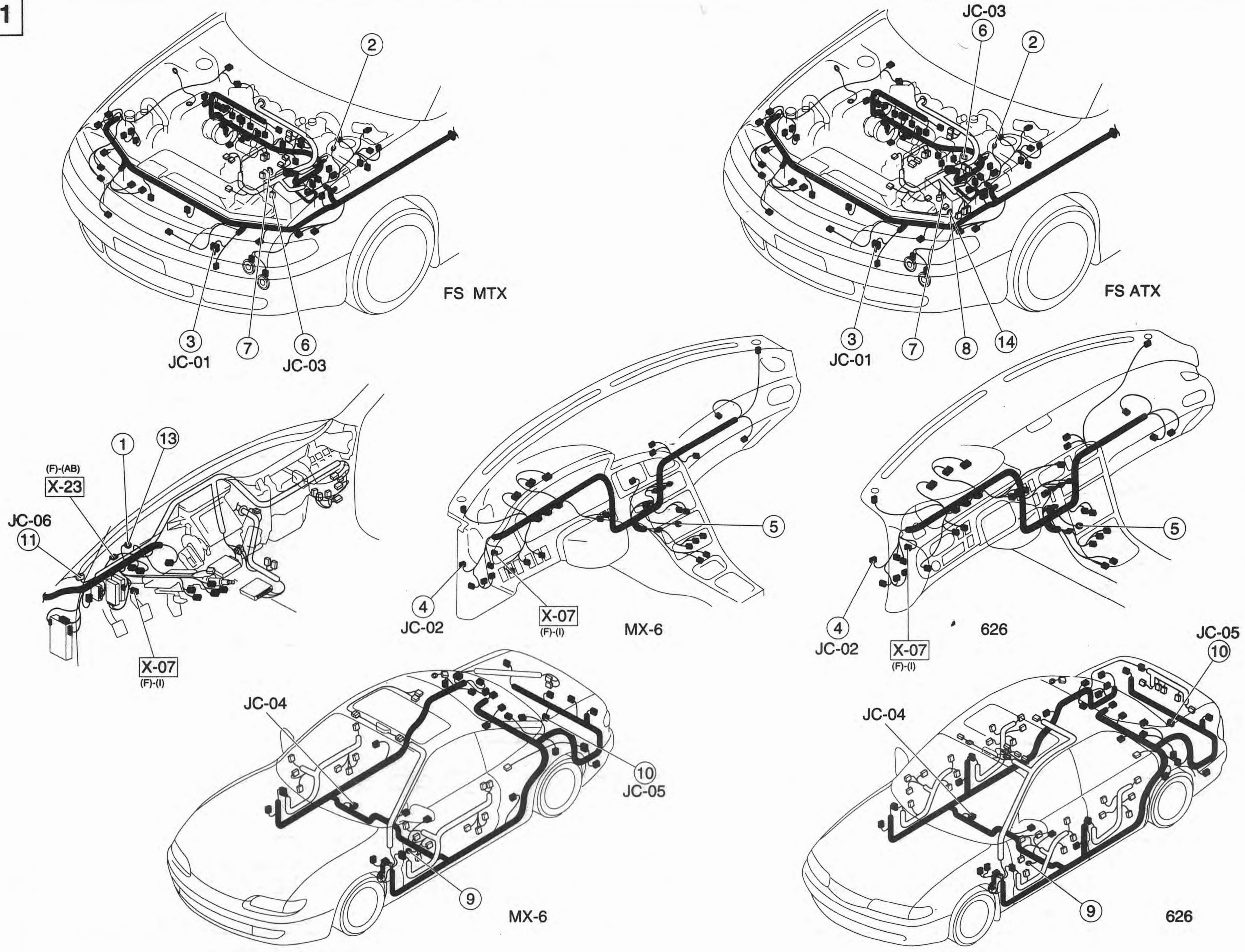

Z WIRING DIAGRAM

Y-2

KL

GROUND POINTS

JC-01 JOINT CONNECTOR (F)	JC-02 JOINT CONNECTOR (I)	JC-03 JOINT CONNECTOR (EM)	JC-04 JOINT CONNECTOR (R)	JC-05 JOINT CONNECTOR (R)	JC-06 JOINT CONNECTOR (AB)	

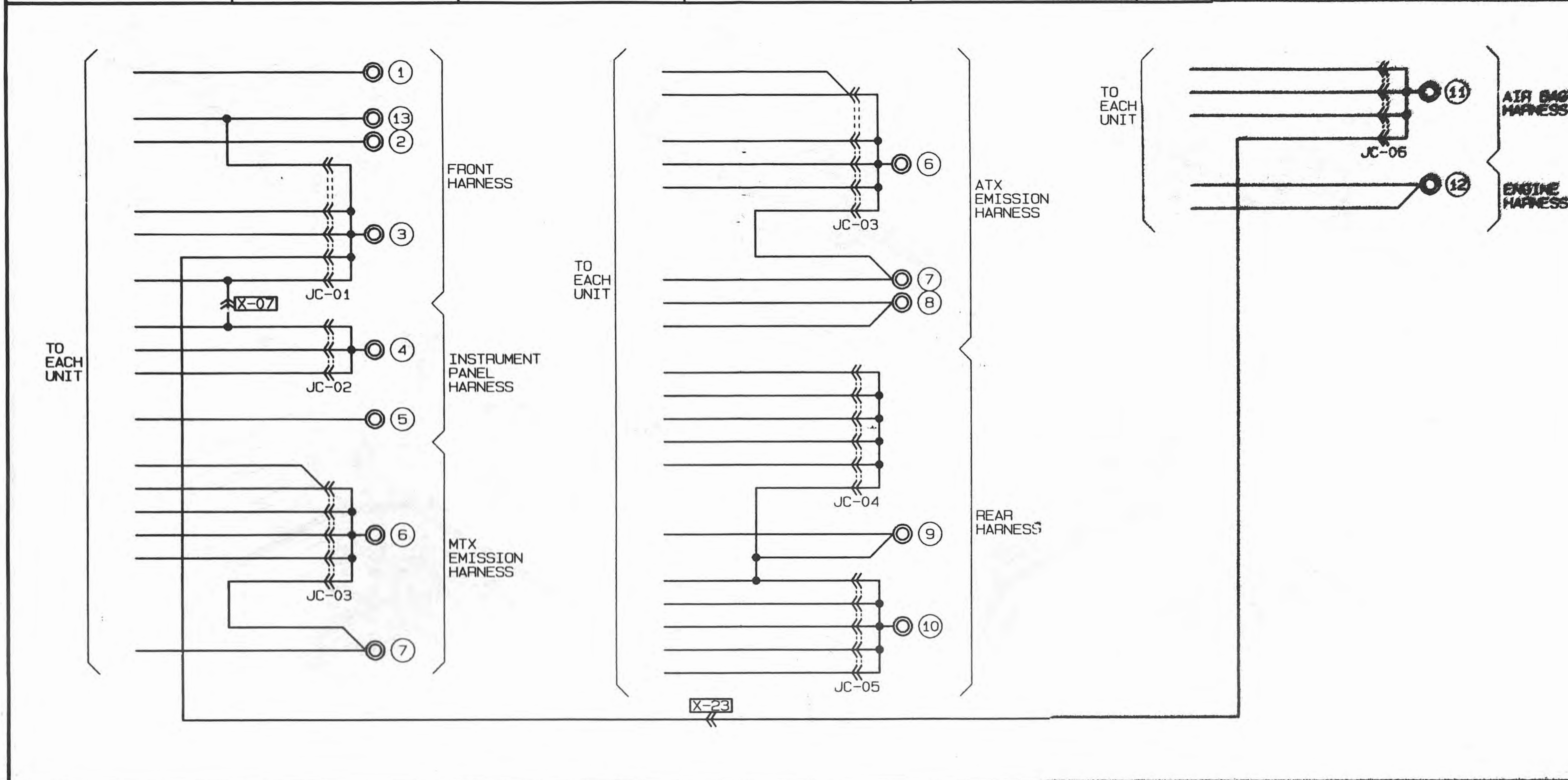

Y-2

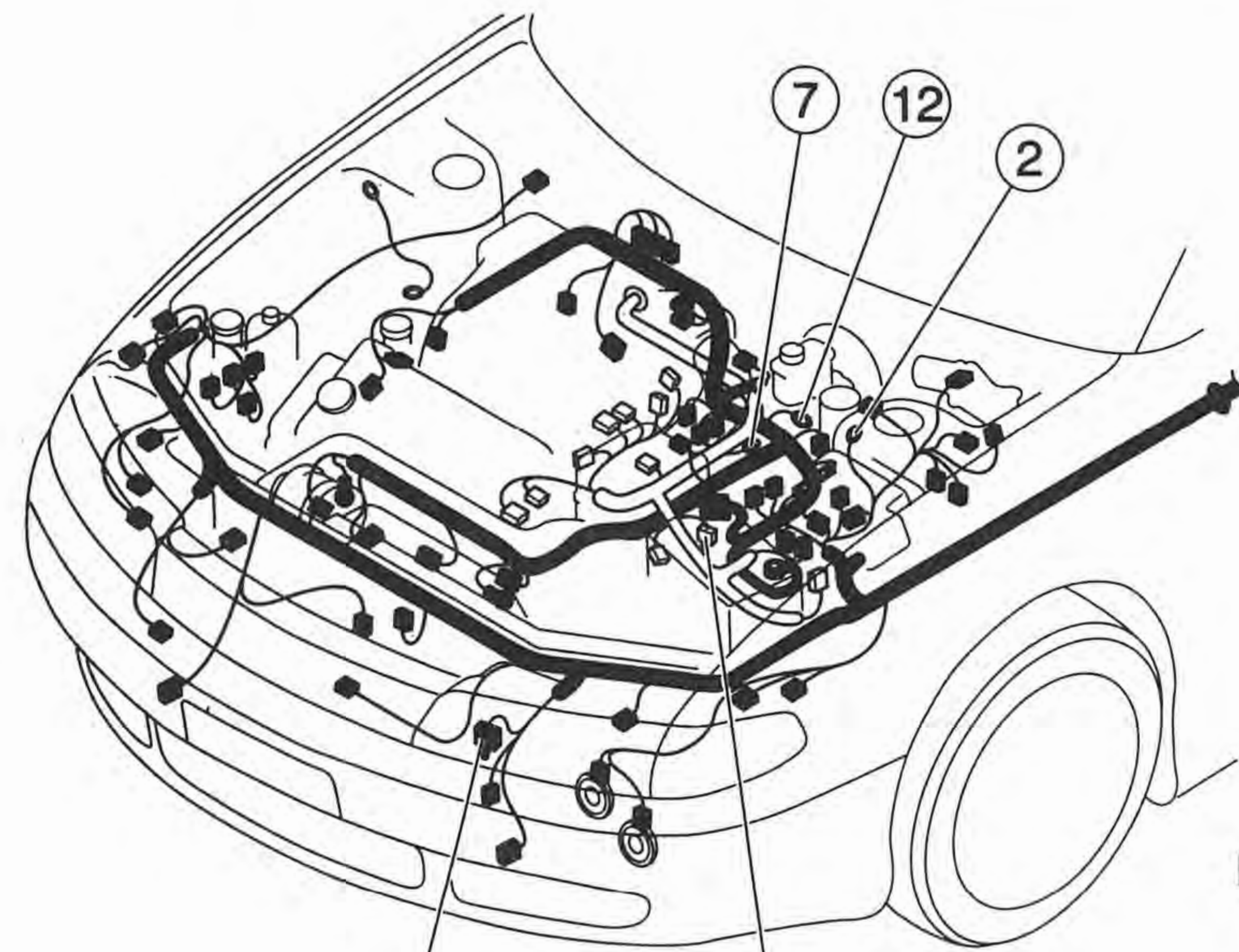

KL MTX

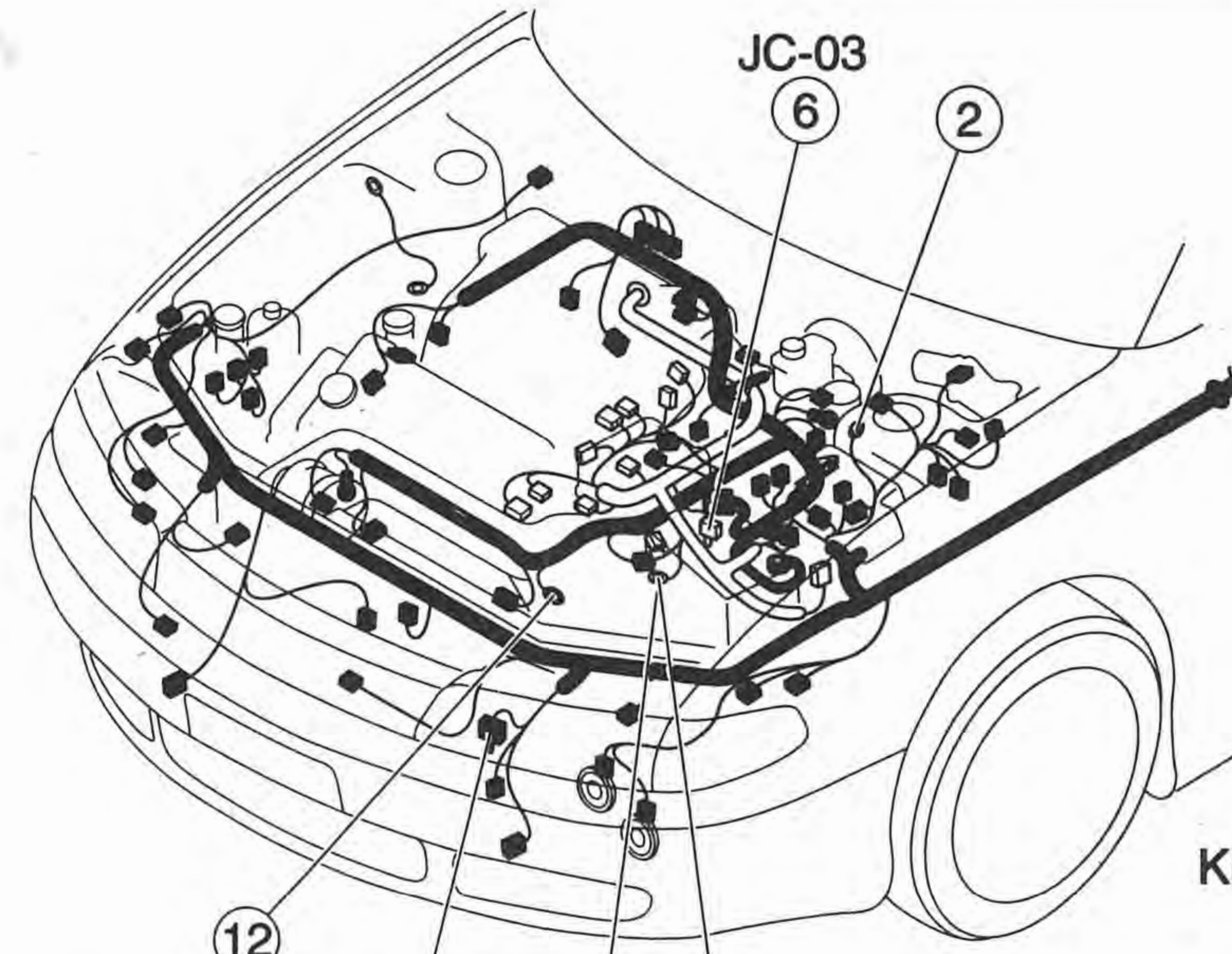

KL ATX

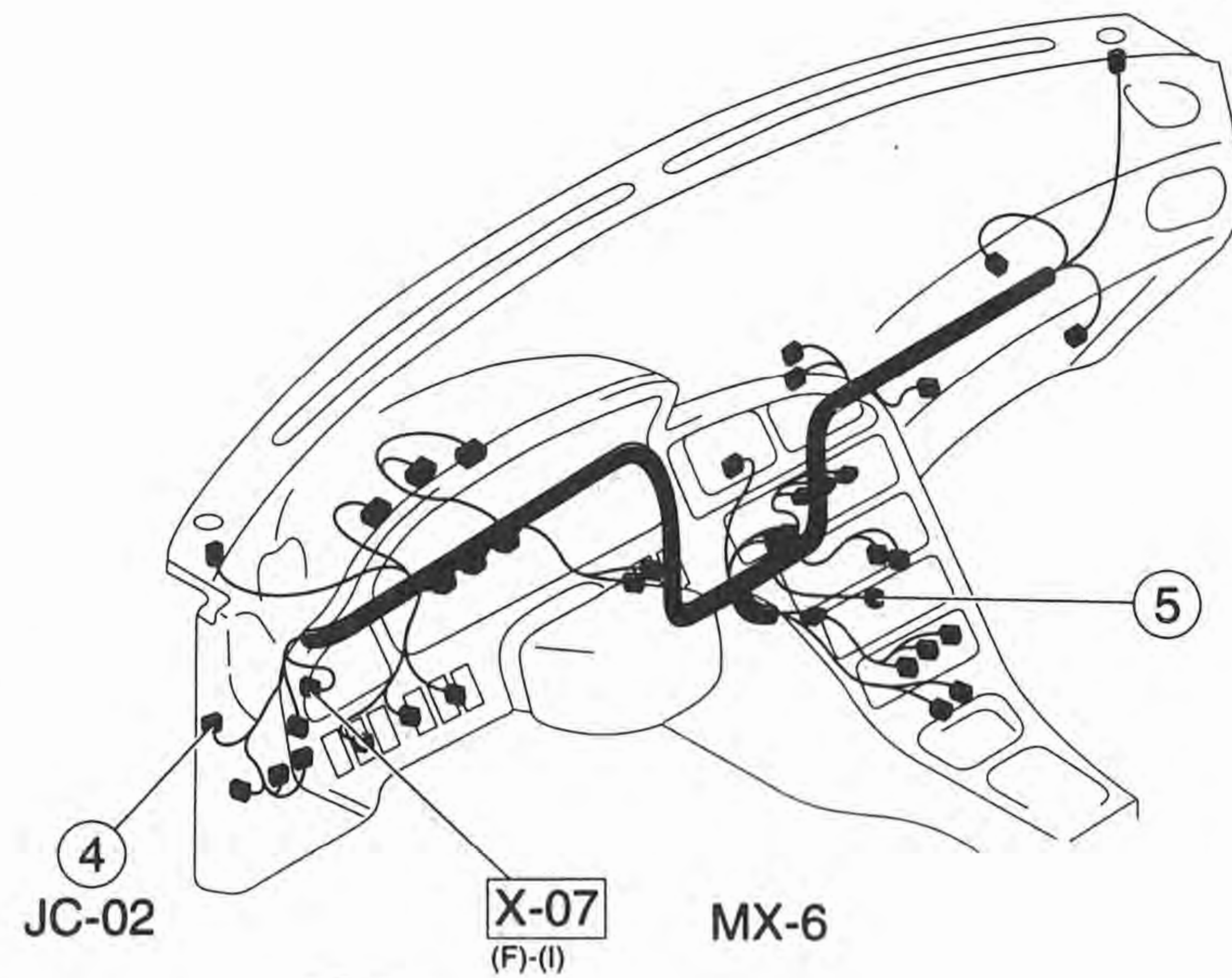
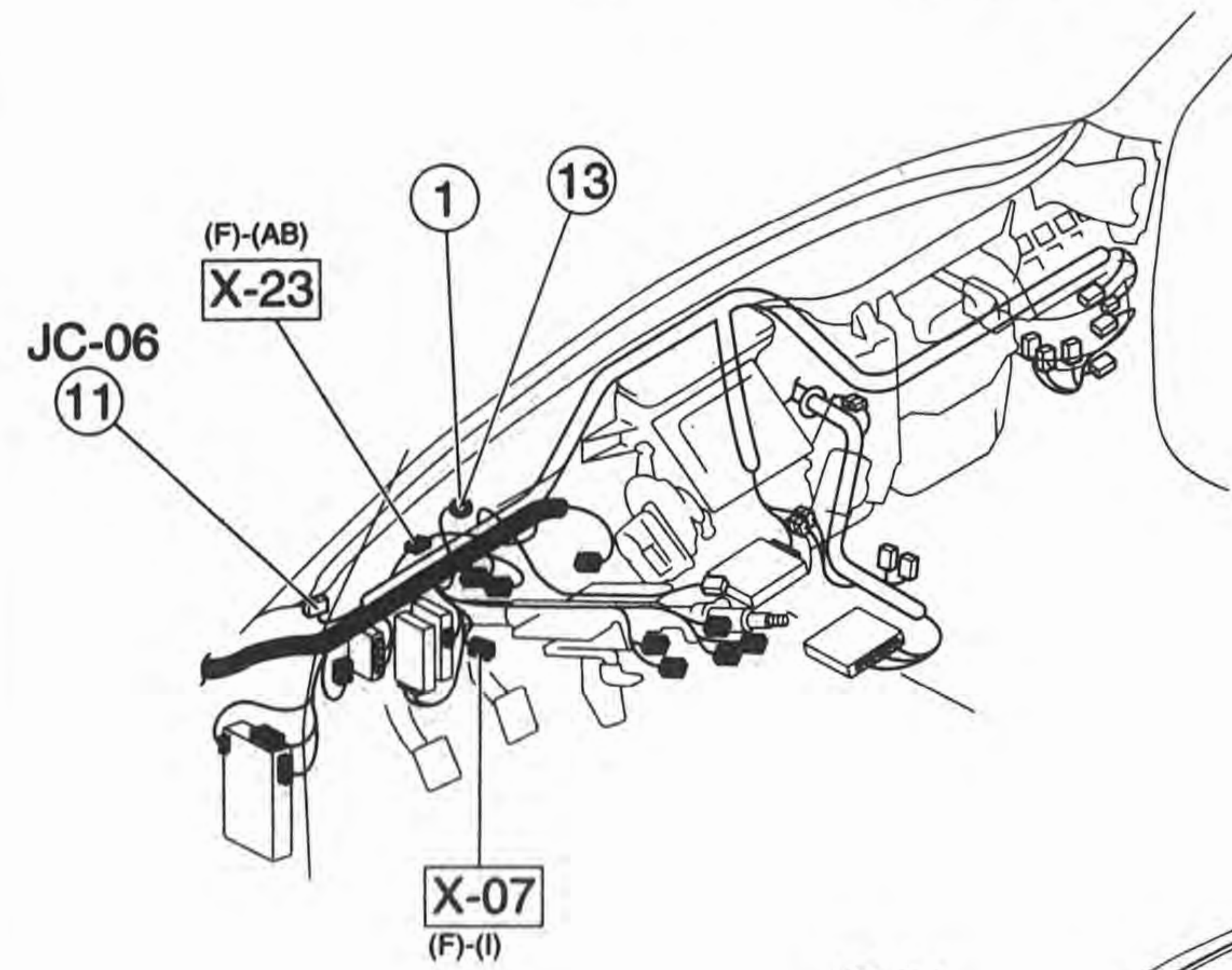

MX-6

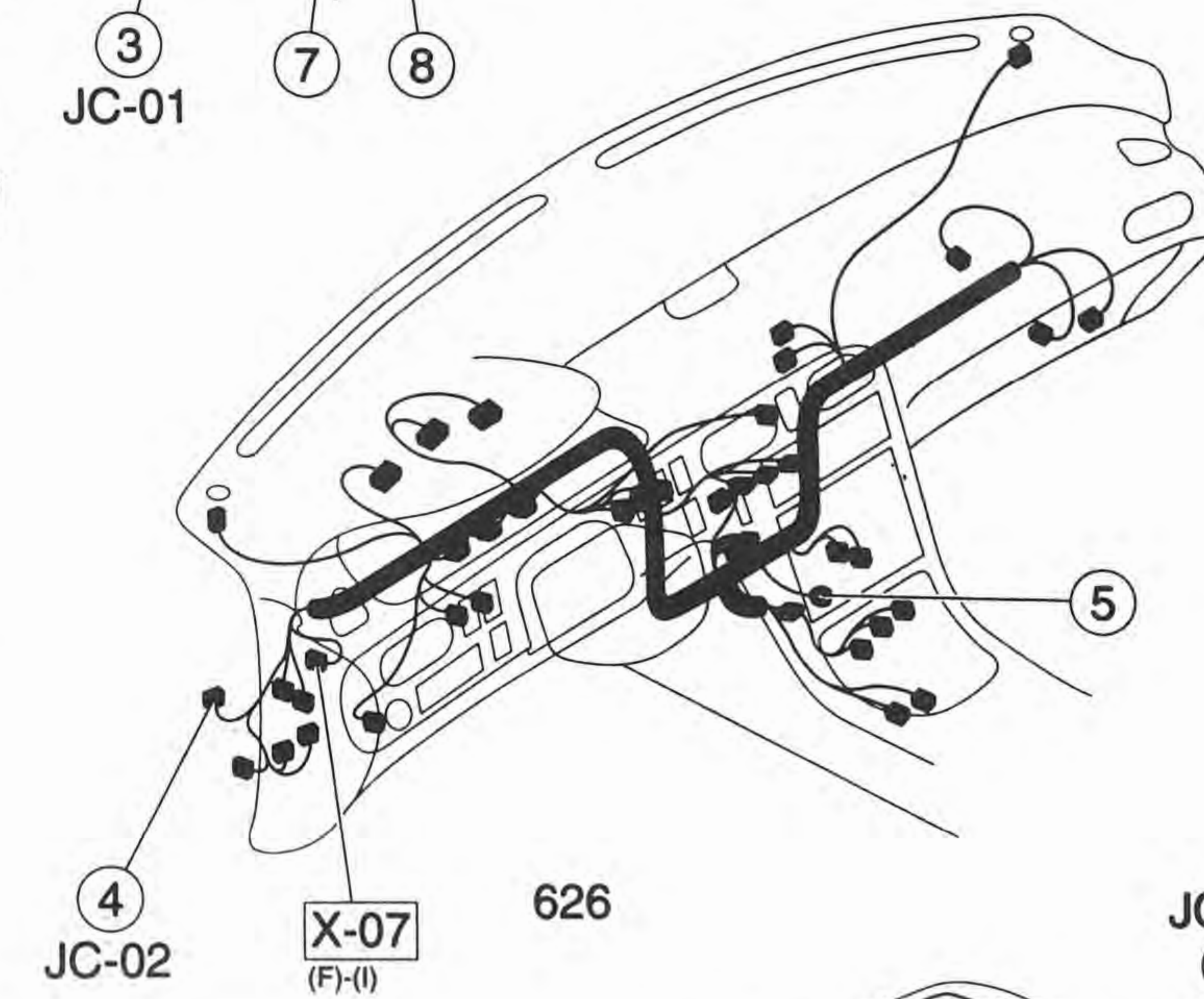

626

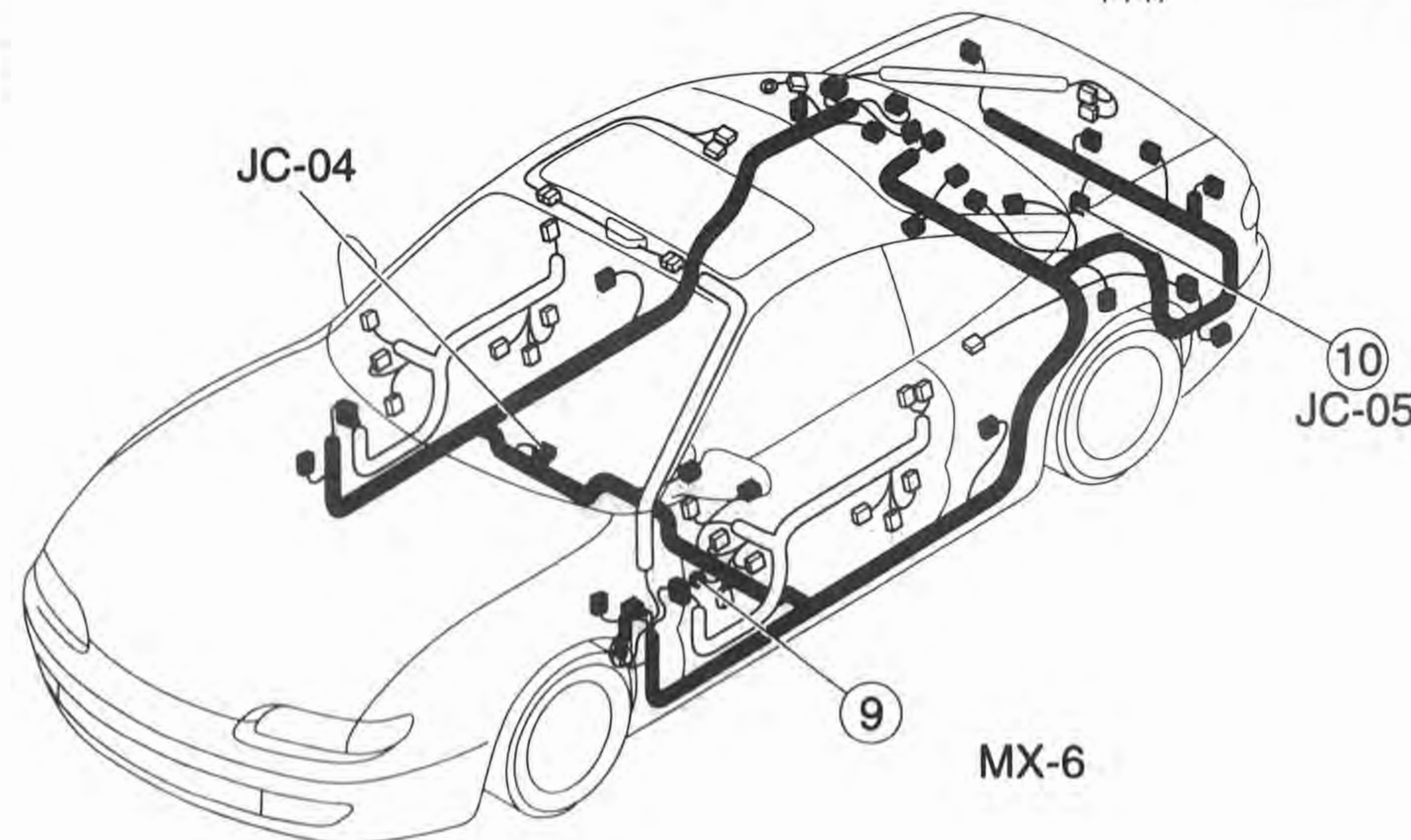

MX-6

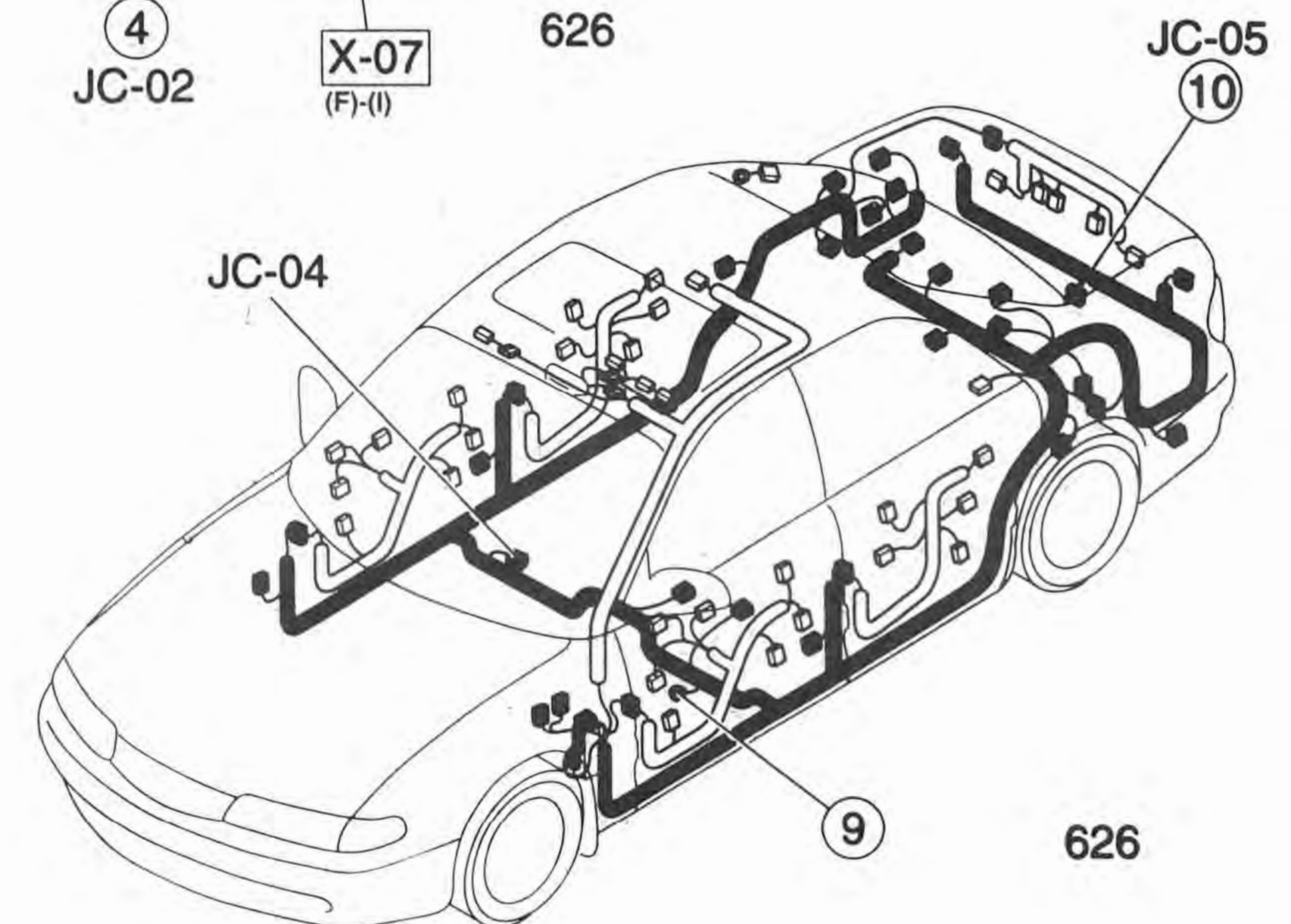

626

W-1 FS ■ ELECTRICAL WIRING SCHEMATIC

WIRING DIAGRAM Z

— CURRENT FROM BATTERY
 - - - CURRENT FROM IG1, IG2
 ···· CURRENT FROM ACC
 — OTHERS





W-2 KL ■ ELECTRICAL WIRING SCHEMATIC

WIRING DIAGRAM Z

— CURRENT FROM BATTERY
 - - - CURRENT FROM IG1, IG2
 - · - CURRENT FROM ACC
 — OTHERS



SYSTEM CIRCUIT	SECTION
FRONT FOG LIGHTS	E-5
HEADLIGHTS	E-1, E-2 E-3, E-4
DAYTIME RUNNING LIGHT (DRL)	E-6
REAR WINDOW DEFROSTER	I-4 I-5
GROVE COMPARTMENT LIGHT	I-1
CHARGING SYSTEM	A-5
FRONT SIDE MARKER LIGHTS	E-7 E-8
REAR SIDE MARKER LIGHTS	E-7 E-8
PARKING LIGHTS	E-7 E-8
LICENCE PLATE LIGHTS	E-7 E-8
TAILLIGHTS	E-7 E-8
ILLUMINATION LIGHTS	I-1
SHIFT-LOCK SYSTEM	H-2
CRUISE CONTROL SYSTEM	Q-2
HORNS	F-4
BRAKE LIGHTS	F-4
HIGH-MOUNT BRAKE LIGHT	F-4
TURN AND HAZARD WARNING LIGHTS	F-1
COURTESY LIGHTS	I-2 I-3
VANITY MIRROR LIGHTS	I-2
TRUNK COMPARTMENT LIGHT	I-4 I-5
AUDIO SYSTEM	J-1
POWER SEAT	P
POWER DOOR LOCKS	K-3 K-4
POWER DOOR LOCKS (WITH KEYLESS ENTRY SYSTEM)	K-5 K-6
POWER OUTSIDE MIRRORS	L-1 L-2
CIGARETTE LIGHTER	I-4 I-5
POWER ANTENNA	J-2



SYSTEM CIRCUIT DIAGRAM/ CONNECTOR LOCATIONS

ENGINE RELATED SYSTEMS

STARTING SYSTEM	
FS ATX	Z-28
FS MTX	Z-30
KL ATX	Z-32
KL MTX	Z-34
CHARGING SYSTEM	Z-36
ENGINE CONTROL SYSTEM	
FS ATX	Z-38
FS MTX	Z-46
KL	Z-52
IGNITION SYSTEM	
FS ATX	Z-38
FS MTX	Z-46
KL	Z-52
FUEL CONTROL SYSTEM	
FS	Z-60
KL	Z-62
COOLANT FAN SYSTEM	
FS	Z-64
KL	Z-66

CHASSIS RELATED SYSTEMS

EC-AT CONTROL SYSTEM	
FS	Z-38
KL	Z-108
SHIFT-LOCK SYSTEM	Z-112
ANTILOCK BRAKE SYSTEM	Z-150

INSTRUMENT CLUSTER-RELATED SYSTEMS

INSTRUMENT CLUSTER	Z-68
--------------------------	------

BODY-RELATED SYSTEMS

WINDSHIELD WIPER AND WASHER	Z-74
HORNS	Z-98
REAR WINDOW DEFROSTER	
626	Z-122
MX-6	Z-124
POWER WINDOWS	
626	Z-130
MX-6	Z-132
POWER DOOR LOCKS	
626	Z-134
MX-6	Z-136
POWER DOOR LOCKS (WITH KEYLESS ENTRY SYSTEM)	
626	Z-138
MX-6	Z-140
POWER OUTSIDE MIRRORS	
626	Z-142
MX-6	Z-144
SLIDING SUNROOF	
626	Z-146
MX-6	Z-148
POWER SEAT	Z-154
CRUISE CONTROL SYSTEM	
EXCEPT FS ATX	Z-156
FS ATX	Z-158
AIR BAG SYSTEM	Z-162
CENTRAL PROCESSING SYSTEM	Z-164
THEFT-DETERRENT SYSTEM	Z-164

INTERIOR LIGHTING SYSTEMS

GLOVE COMPARTMENT LIGHT	Z-114
ILLUMINATION LIGHTS	Z-114
COUTESY LIGHTS	
626	Z-118
MX-6	Z-120
IGNITION KEY ILLUMINATION	
626	Z-118
MX-6	Z-120
INTERIOR LIGHT	
626	Z-118
MX-6	Z-120
SPOT LIGHTS	
626	Z-118
MX-6	Z-120
VANITY MIRROR LIGHTS	Z-118
TRUNK COMPARTMENT LIGHT	
626	Z-122
MX-6	Z-124

EXTERIOR LIGHTING SYSTEMS

HEADLIGHTS	
FEDERAL AND CALIFORNIA 626	Z-76
FEDERAL AND CALIFORNIA MX-6	Z-78
CANADA 626	Z-80
CANADA MX-6	Z-82
FRONT FOG LIGHTS	
KL	Z-84
DAYTIME RUNNING LIGHT(DRL)	
CANADA	Z-86
LICENCE PLATE LIGHTS	
626	Z-88
MX-6	Z-90
PARKING LIGHTS	
626	Z-88
MX-6	Z-90
FRONT SIDE MARKER LIGHTS	
626	Z-88
MX-6	Z-90
REAR SIDE MARKER LIGHTS	
626	Z-88
MX-6	Z-90
TAILLIGHTS	
626	Z-88
MX-6	Z-90
TURN AND HAZARD WARNING LIGHTS	Z-92
BACK-UP LIGHTS	
626	Z-94
MX-6	Z-96
BRAKE LIGHTS	Z-98
HIGH MOUNT BRAKE LIGHT	Z-98

AIR CONDITIONING-RELATED SYSTEMS

HEATER AND AIR CONDITIONER	Z-100
CONDENSER FAN SYSTEM	
FS	Z-104
KL	Z-106

ACCESSORIES

CIGARETTE LIGHTER	
626	Z-122
MX-6	Z-124
AUDIO SYSTEM	Z-126
POWER ANTENNA	Z-128

OTHER

DATA LINK CONNECTOR	
FS	Z-168
KL	Z-170

Z WIRING DIAGRAM

A-1 FS ATX ■ STARTING SYSTEM

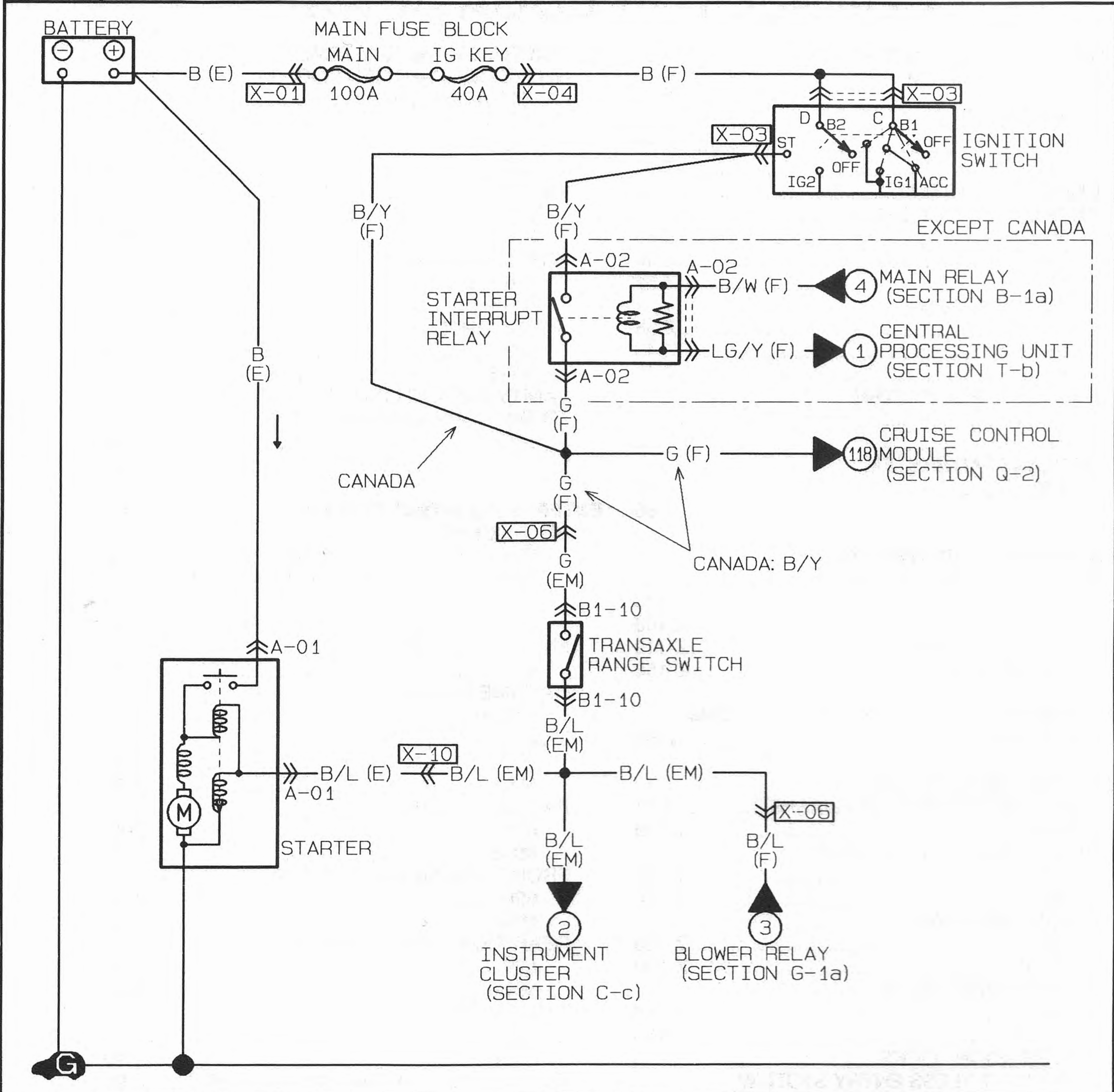

A-01 STARTER (E)



A-02 STARTER INTERRUPT RELAY (F)

*	B/Y	B/W
G	*	LG/Y

B1-10 TRANSAXLE RANGE SWITCH (EM)

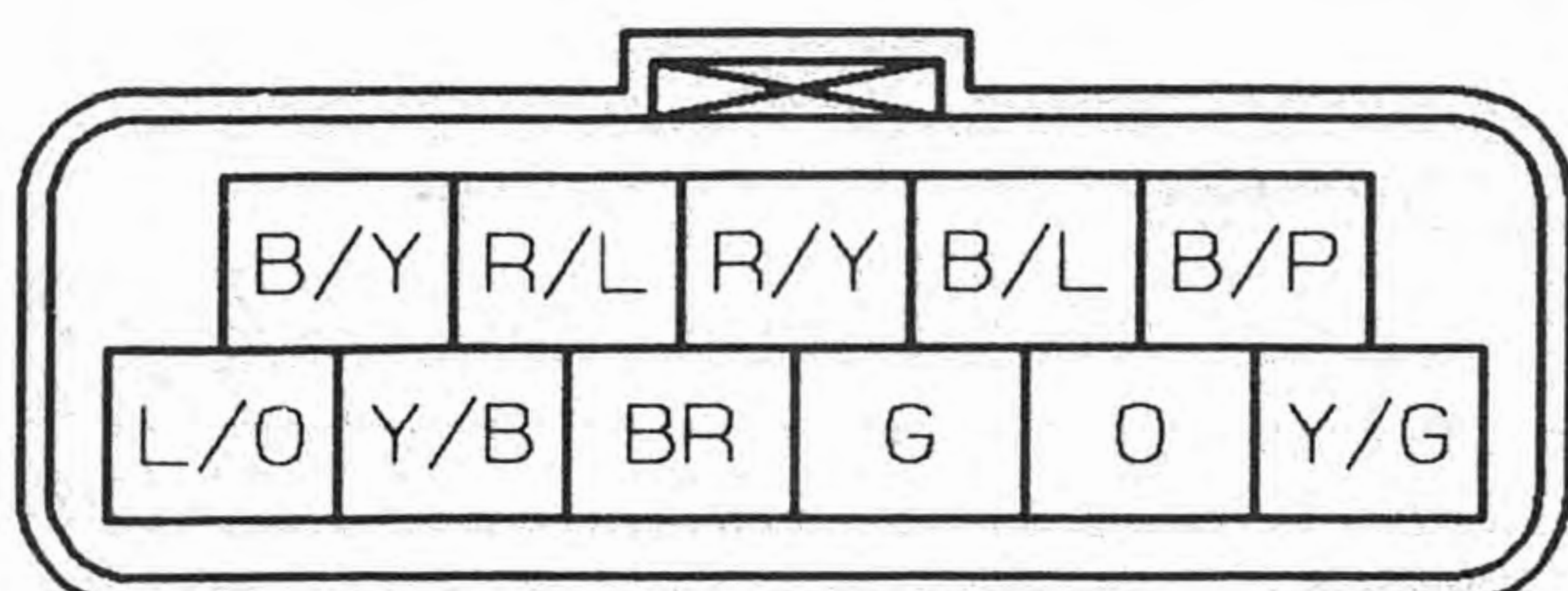

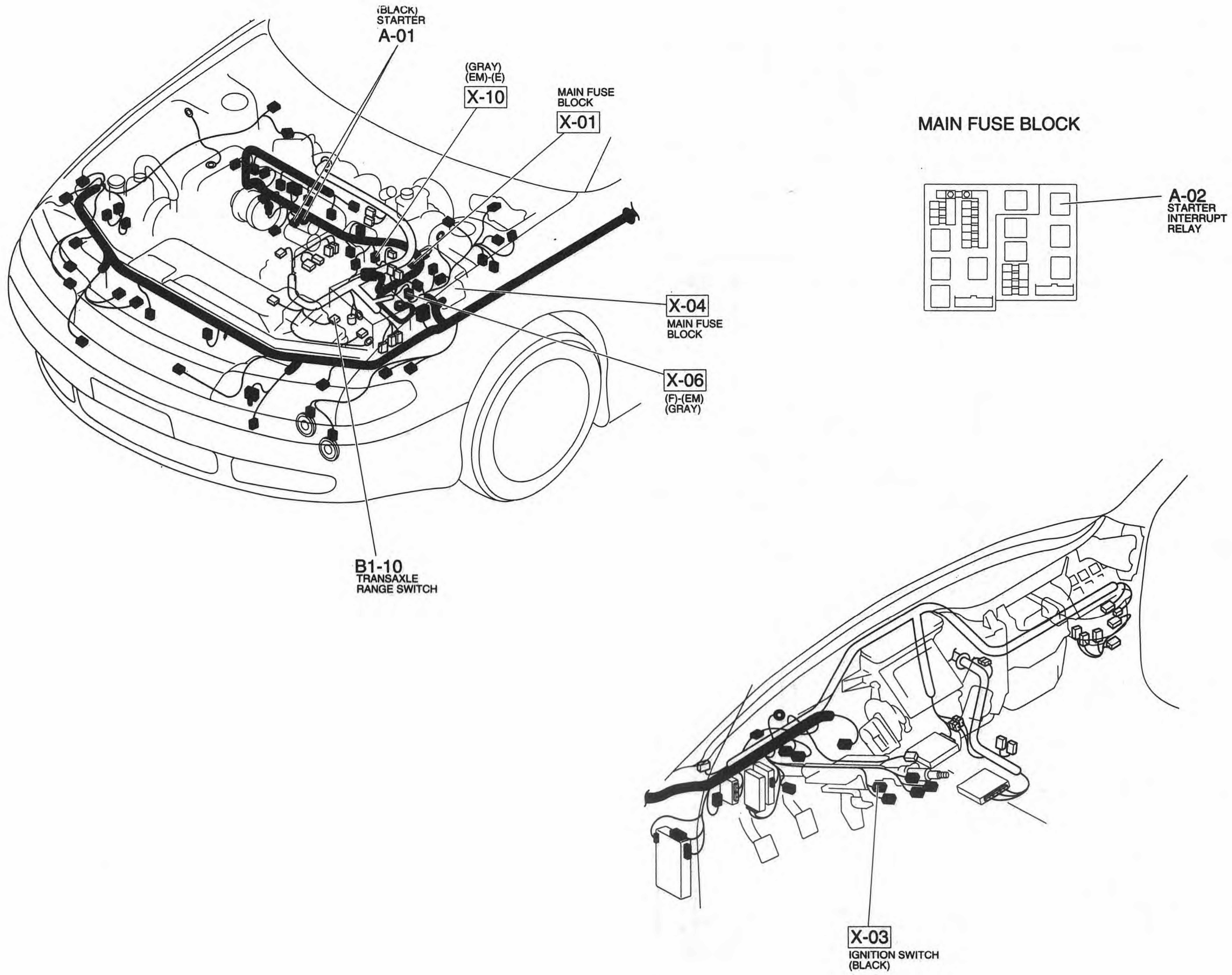

A-1

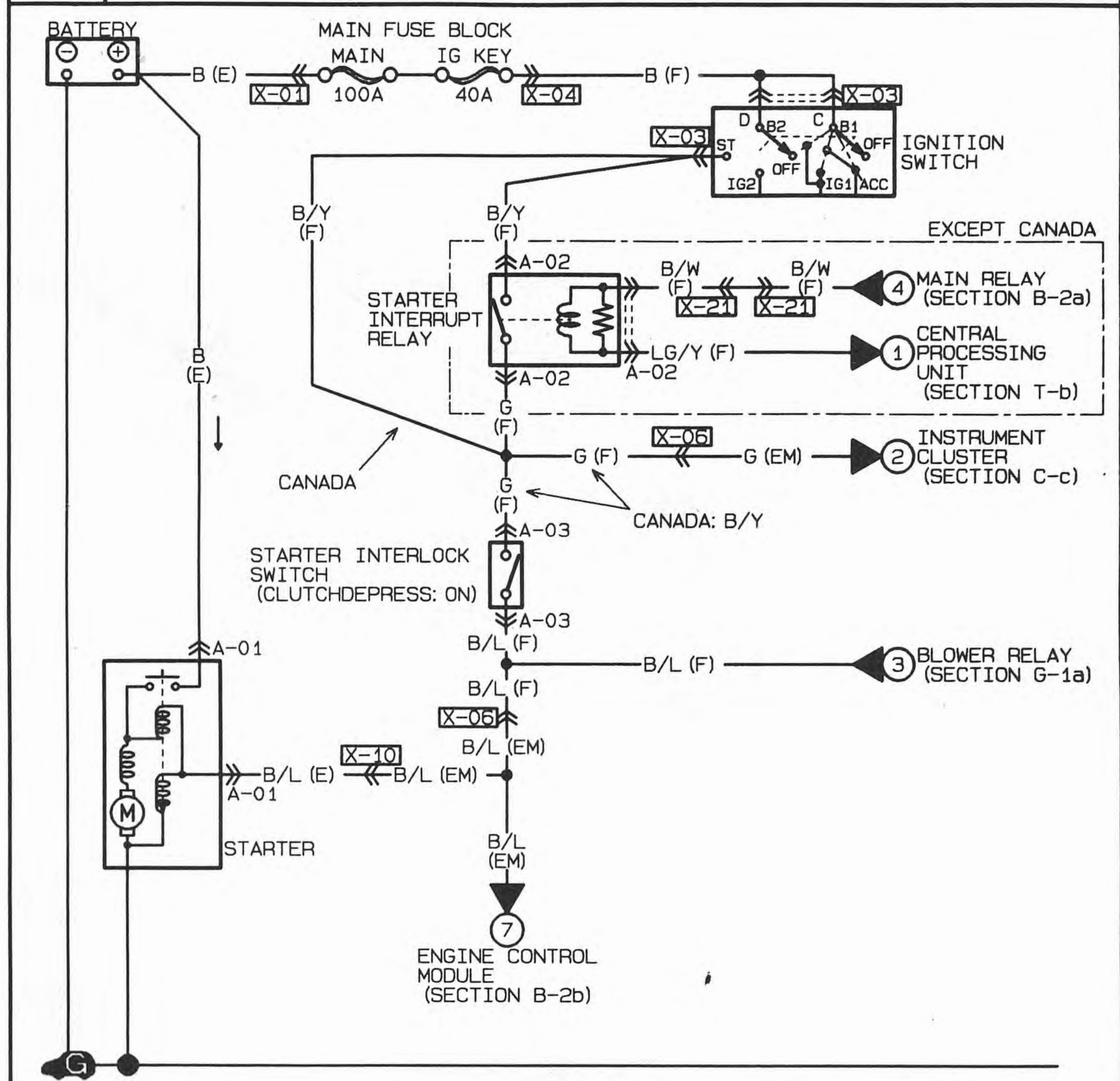

A-2 FS MTX ■ STARTING SYSTEM

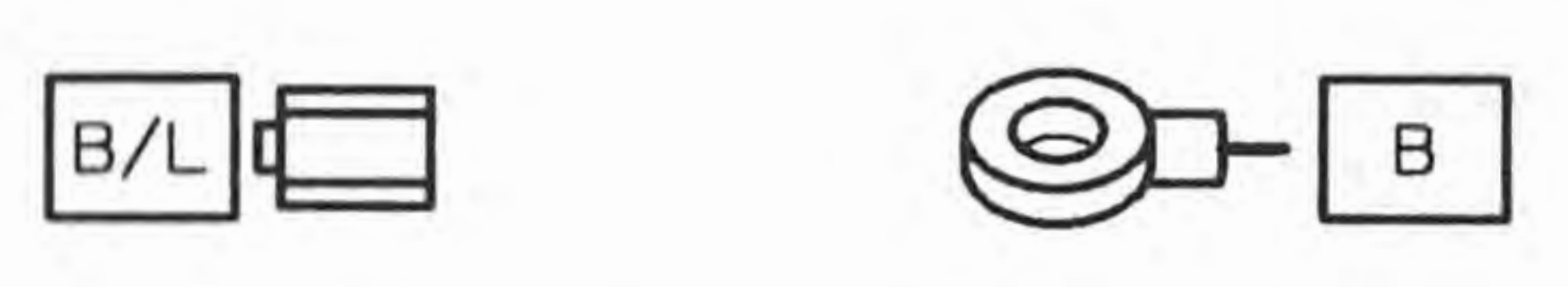

<p>A-01 STARTER (E)</p> 	<p>A-02 STARTER INTERRUPT RELAY (F)</p> <table border="1" data-bbox="2293 1383 2499 1489"> <tr> <td>*</td> <td>B/Y</td> <td>B/W</td> </tr> <tr> <td>G</td> <td>*</td> <td>LG/Y</td> </tr> </table>	*	B/Y	B/W	G	*	LG/Y
*	B/Y	B/W					
G	*	LG/Y					
<p>A-03 STARTER INTERLOCK SWITCH (F)</p> 							

A-2

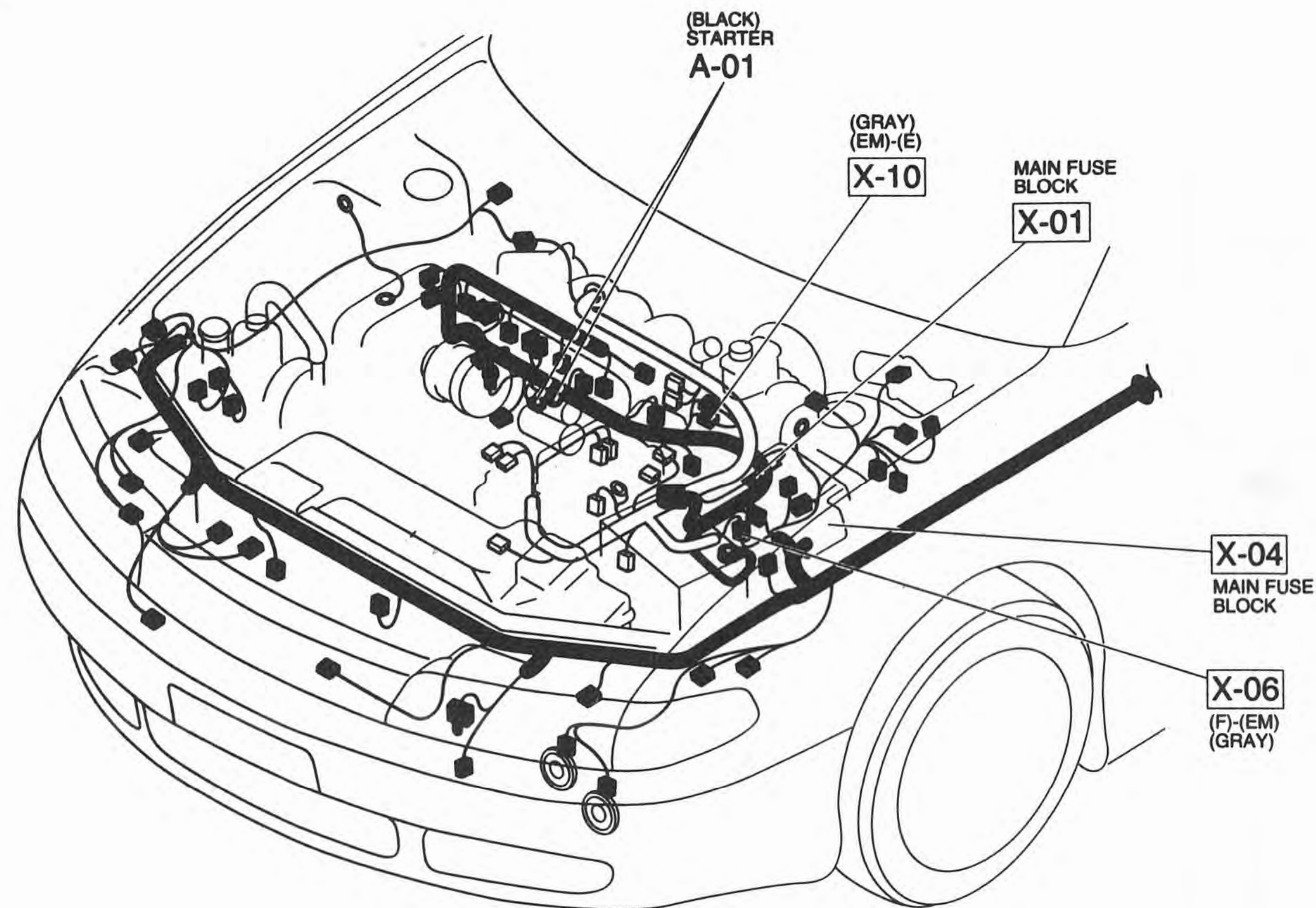

MAIN FUSE BLOCK

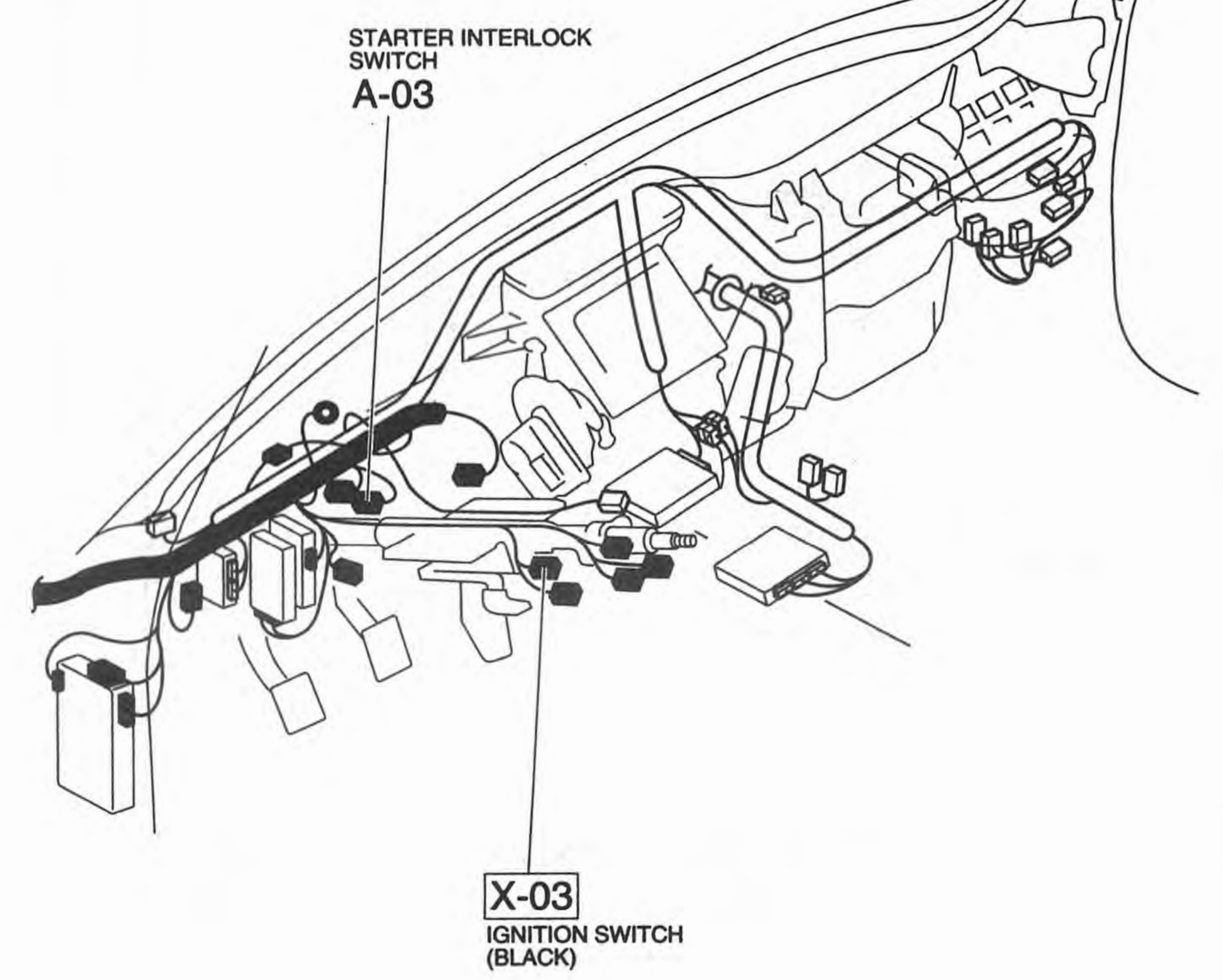
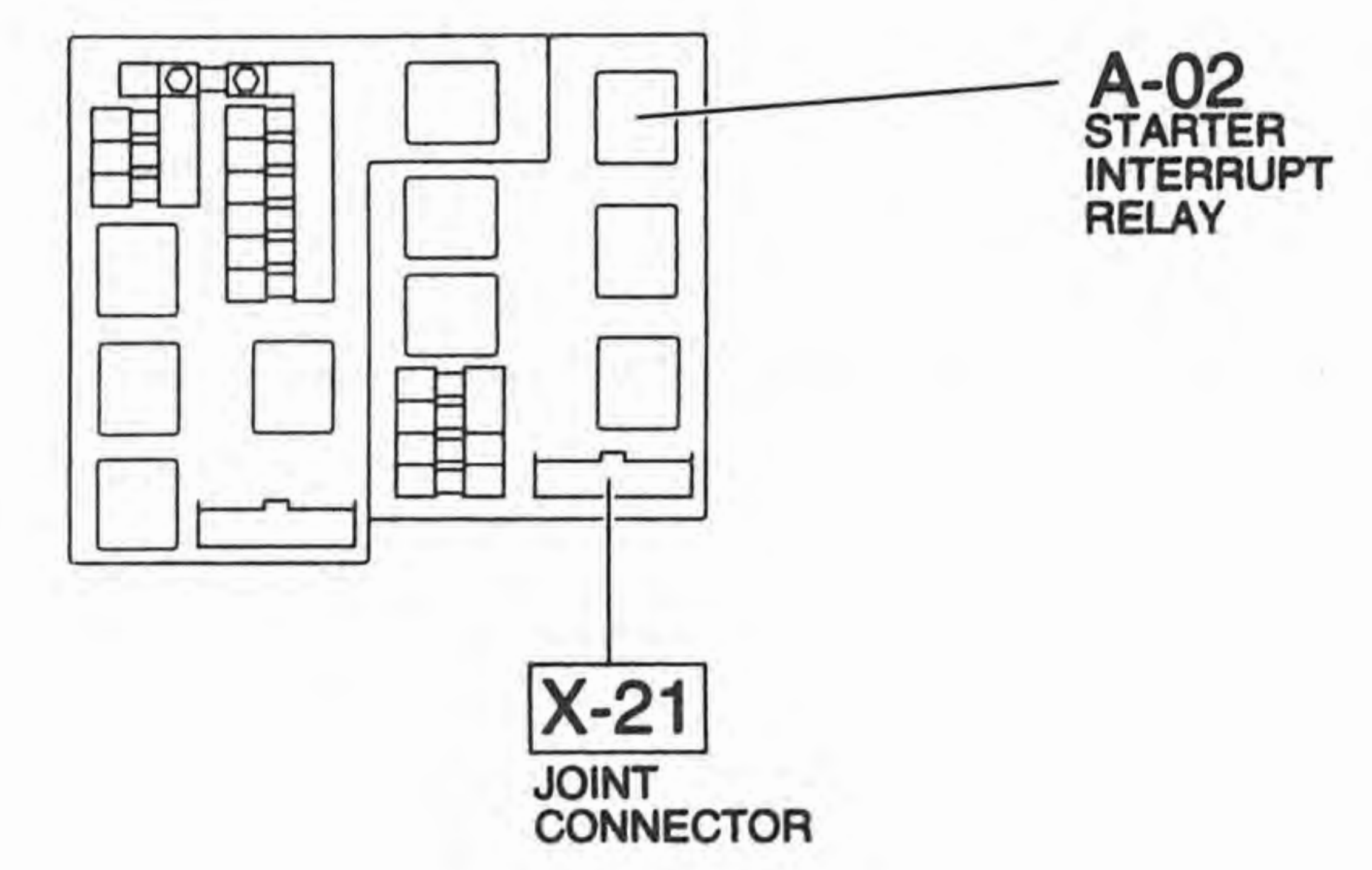

A-3 KL ATX ■ STARTING SYSTEM

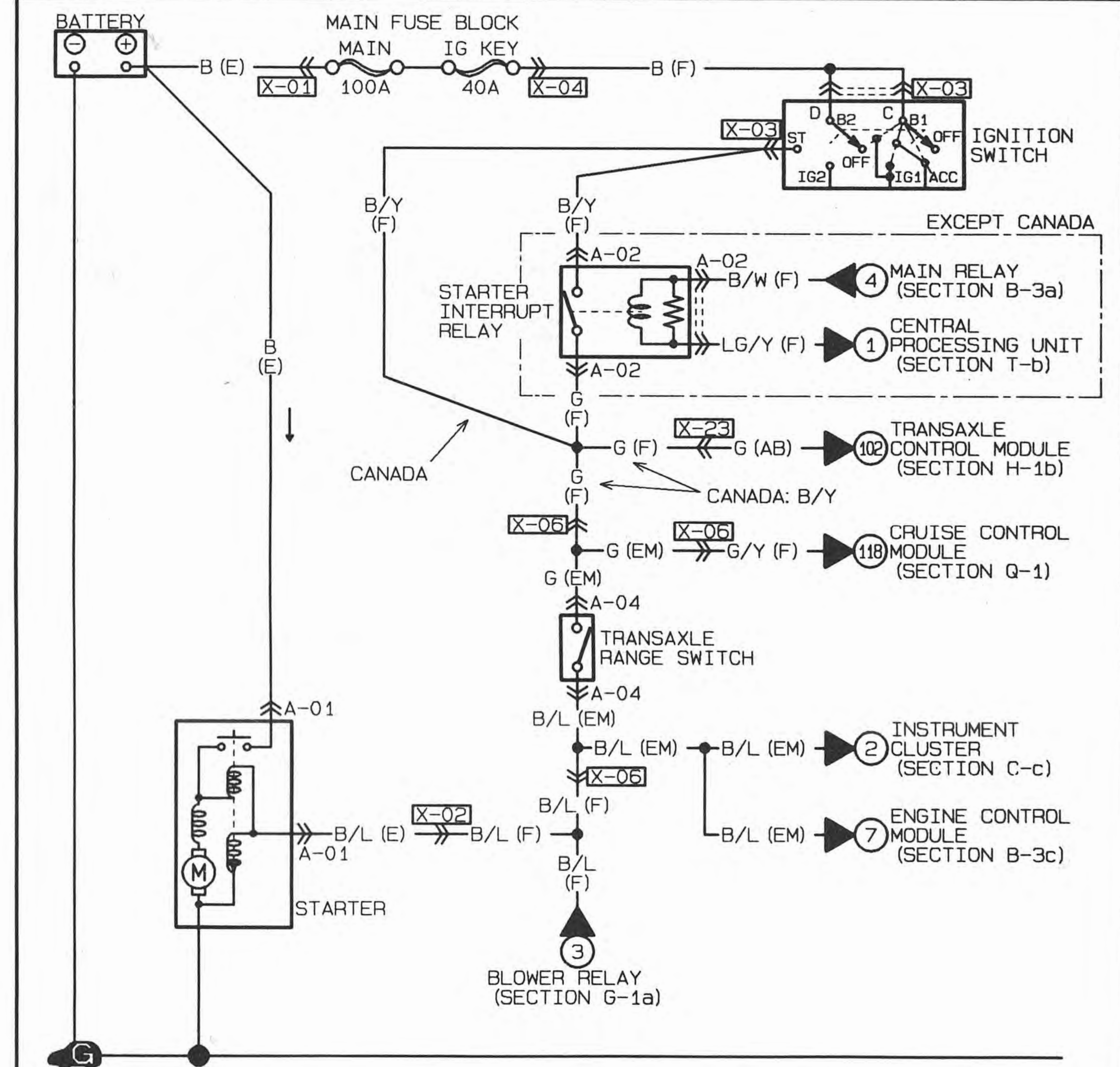

A-01 STARTER (E)

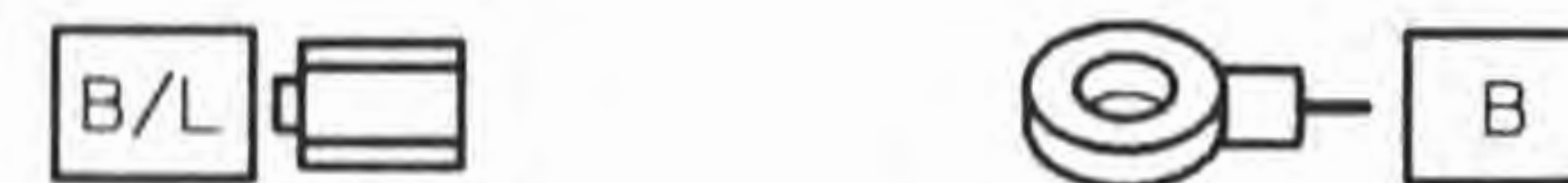

A-02 STARTER INTERRUPT RELAY (F)

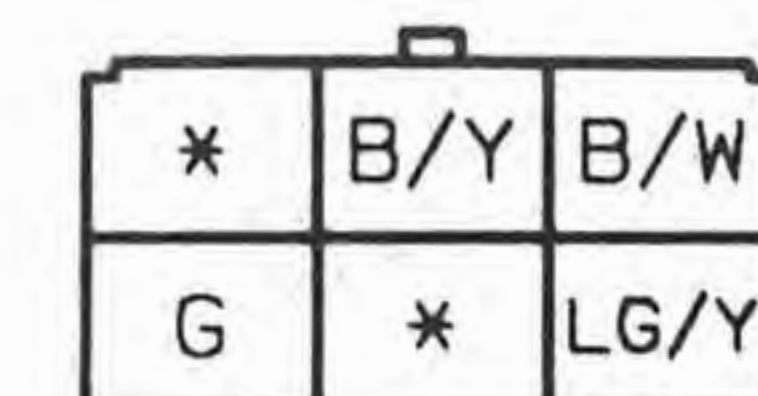

A-04 TRANSAXLE RANGE SWITCH (EM)

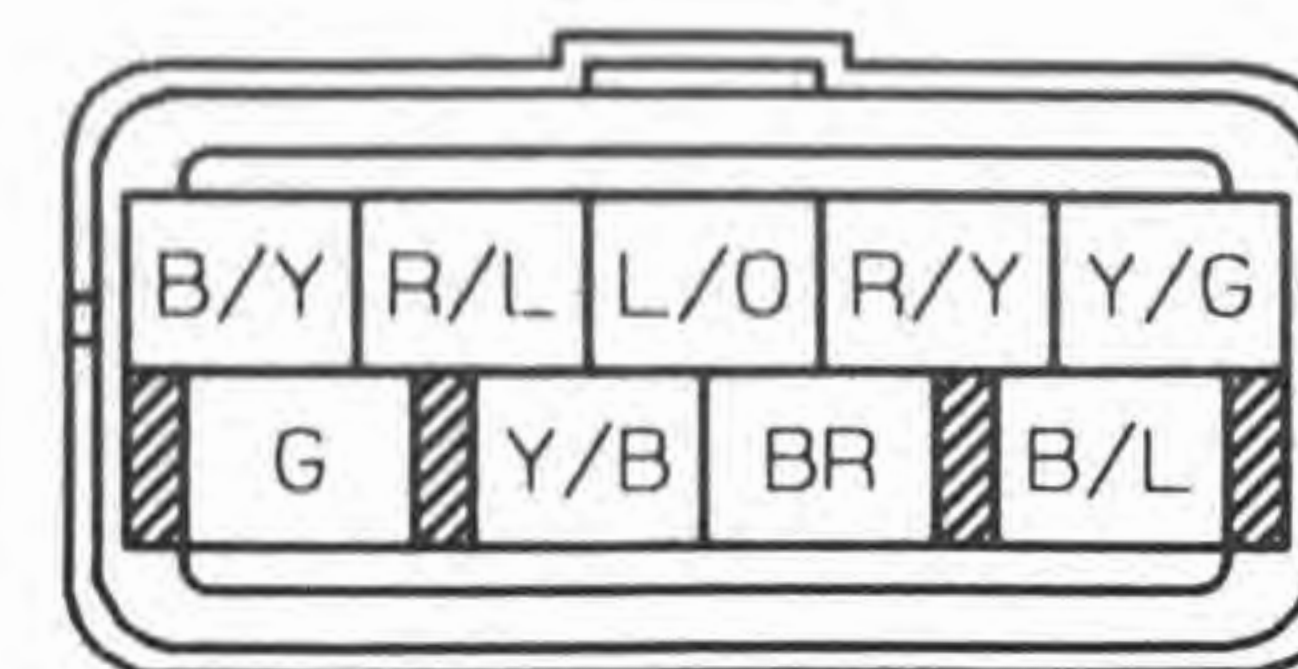

A-3

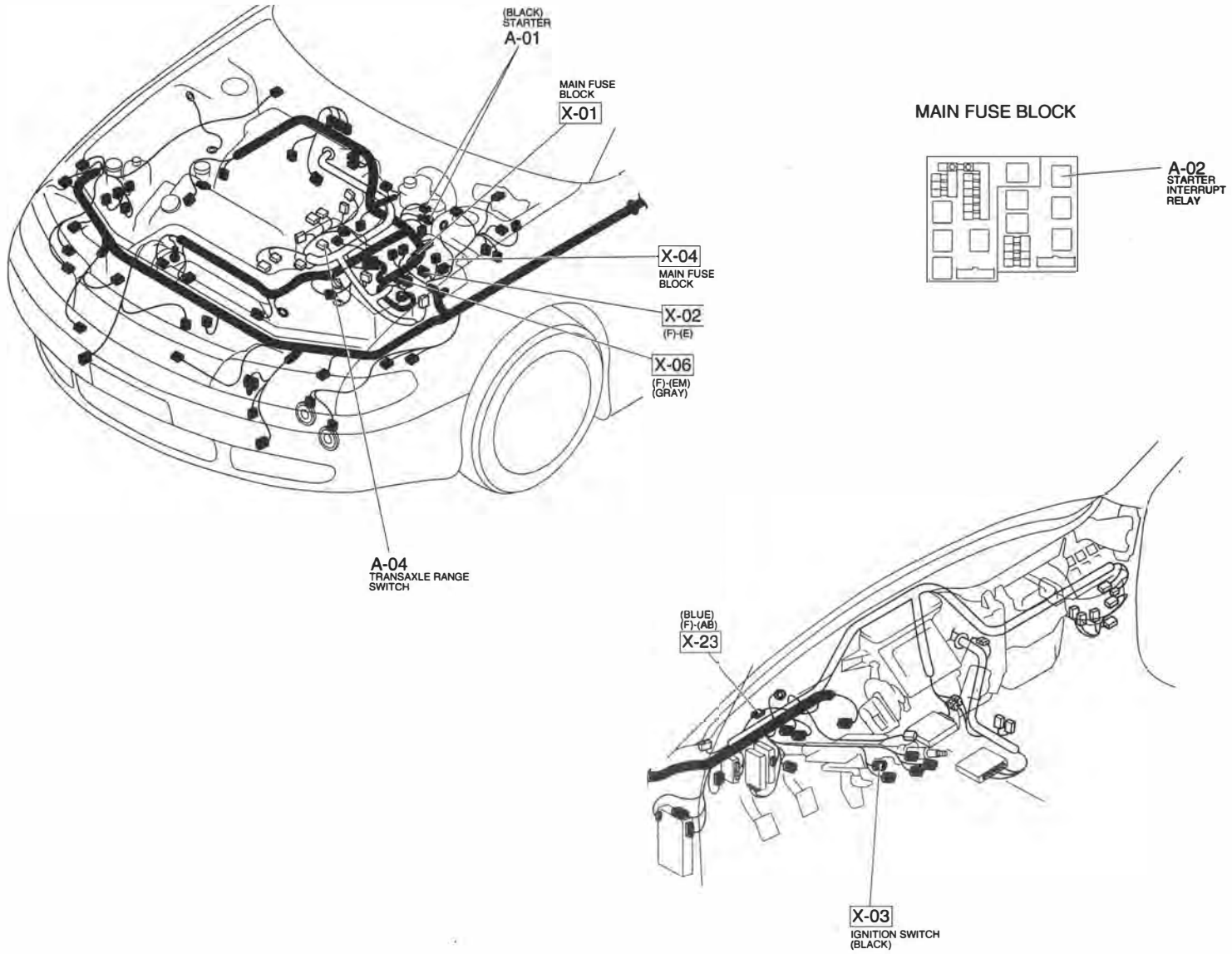

A-4 KL MTX ■ STARTING SYSTEM

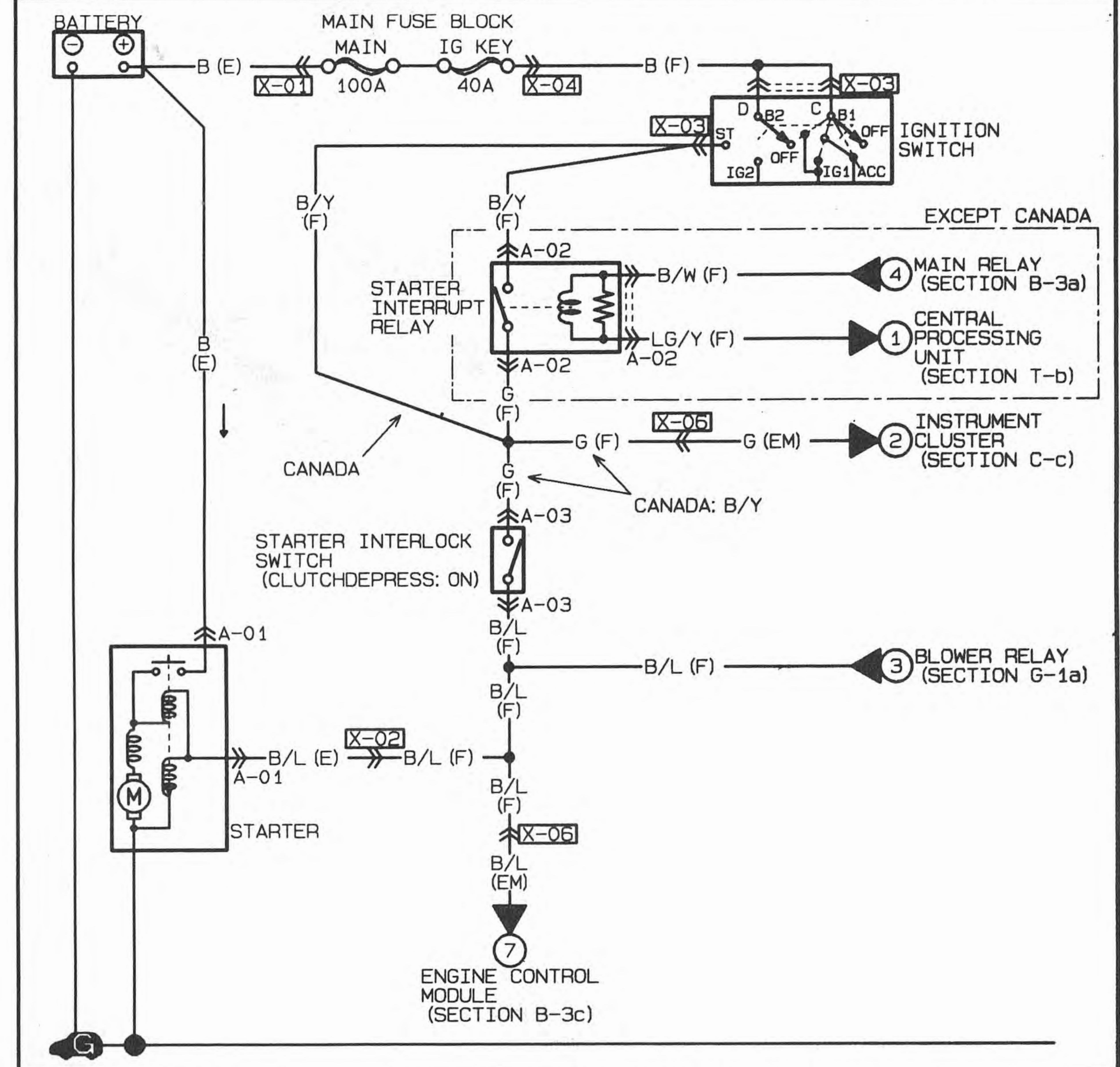

<p>A-01 STARTER (E)</p>	<p>A-02 STARTER INTERRUPT RELAY (F)</p> <table border="1"> <tr> <td>*</td> <td>B/Y</td> <td>B/W</td> </tr> <tr> <td>G</td> <td>*</td> <td>LG/Y</td> </tr> </table>	*	B/Y	B/W	G	*	LG/Y
*	B/Y	B/W					
G	*	LG/Y					
<p>A-03 STARTER INTERLOCK SWITCH (F)</p>							

A-4

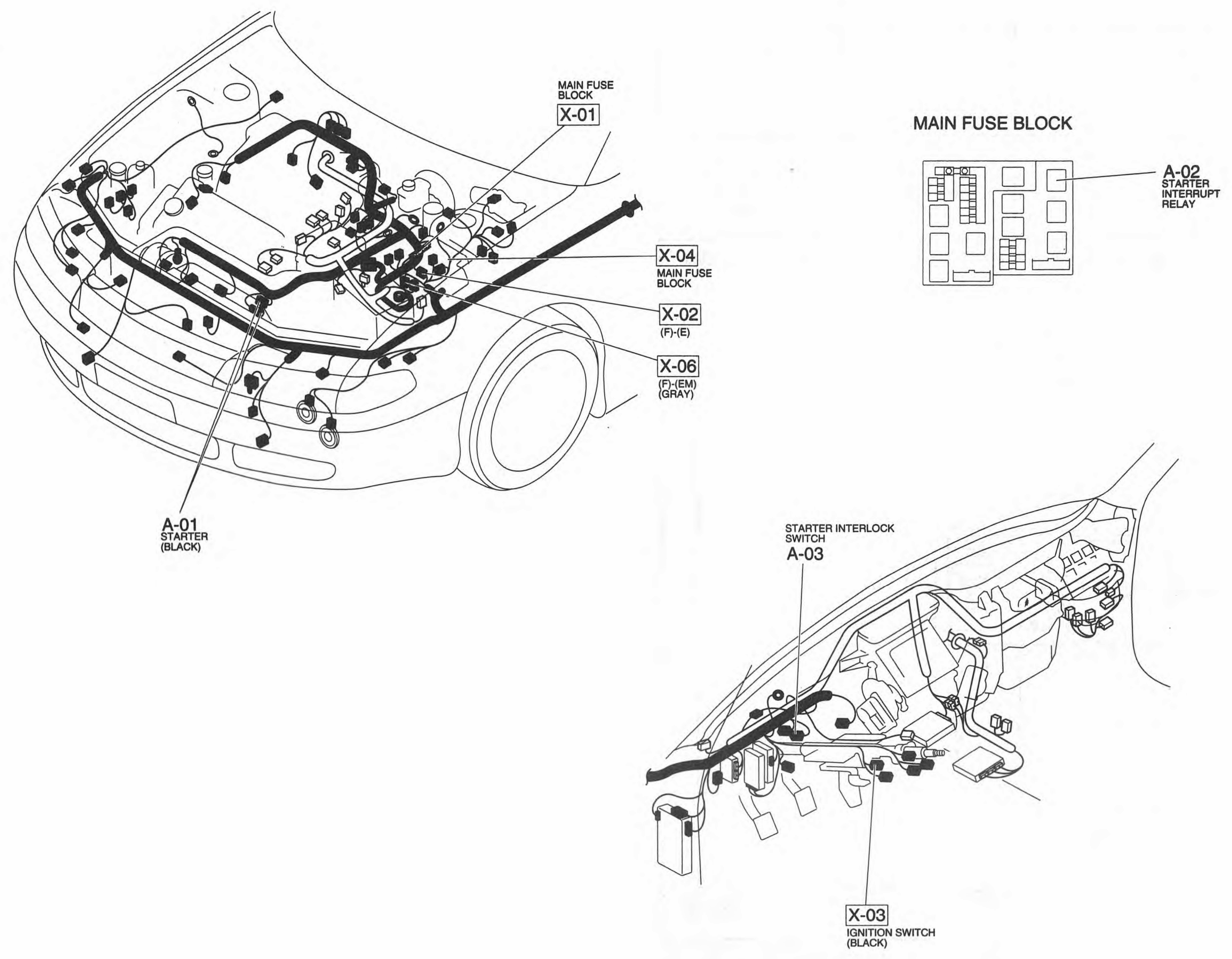

Z WIRING DIAGRAM

A-5 ■ CHARGING SYSTEM

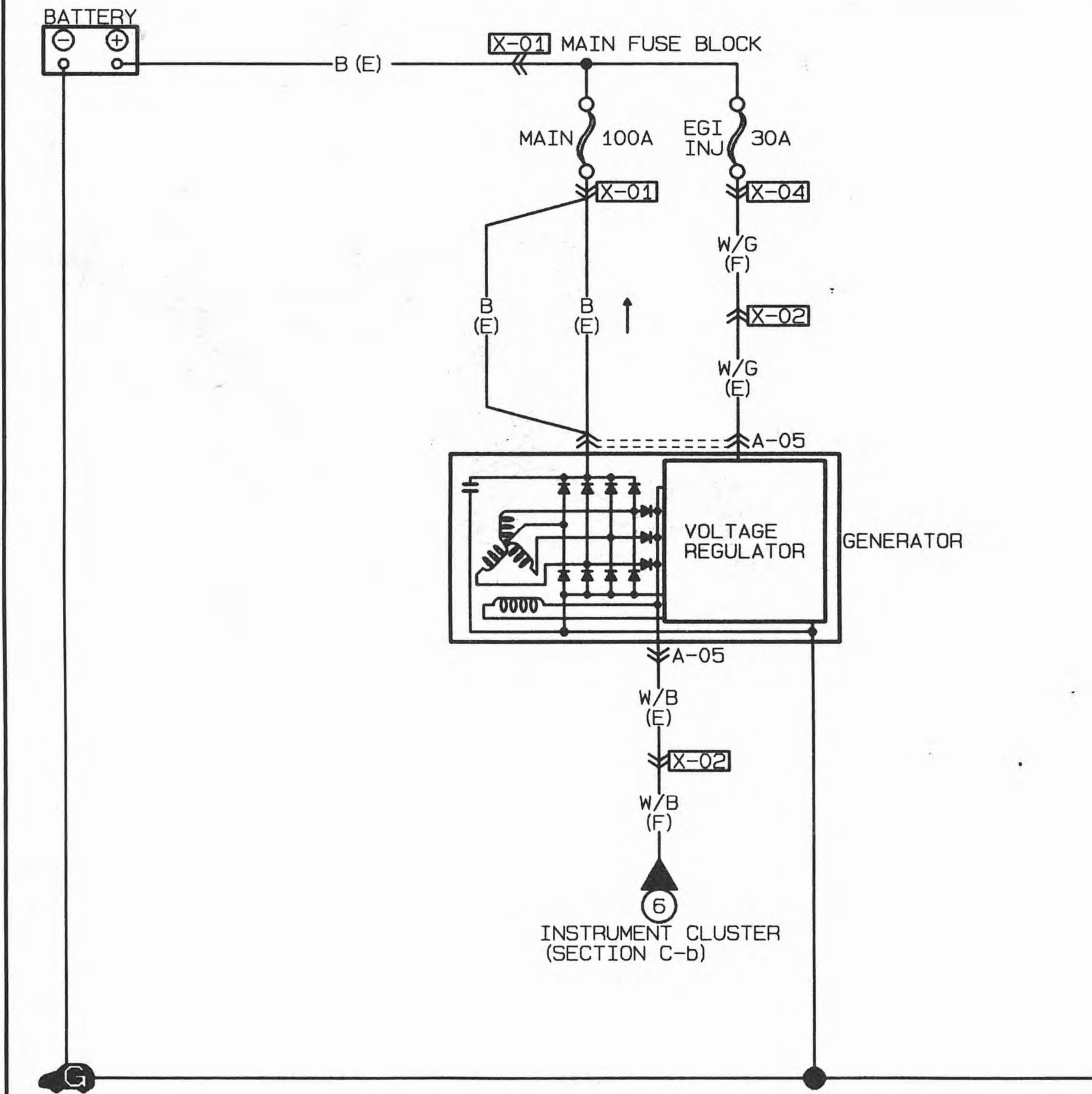

A-05 GENERATOR (E)

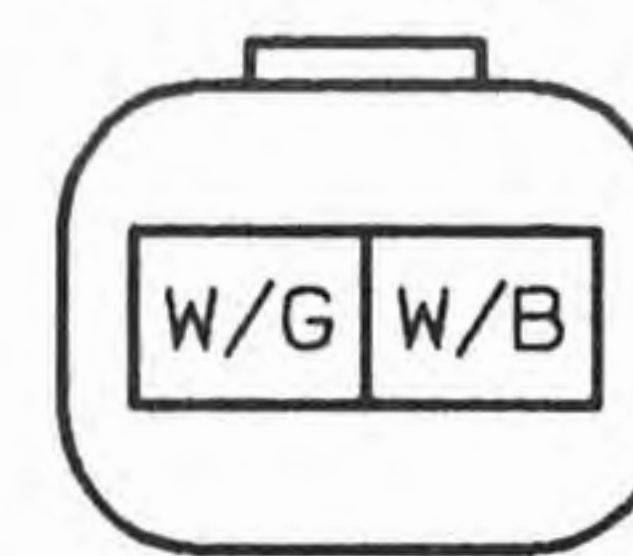

A-5

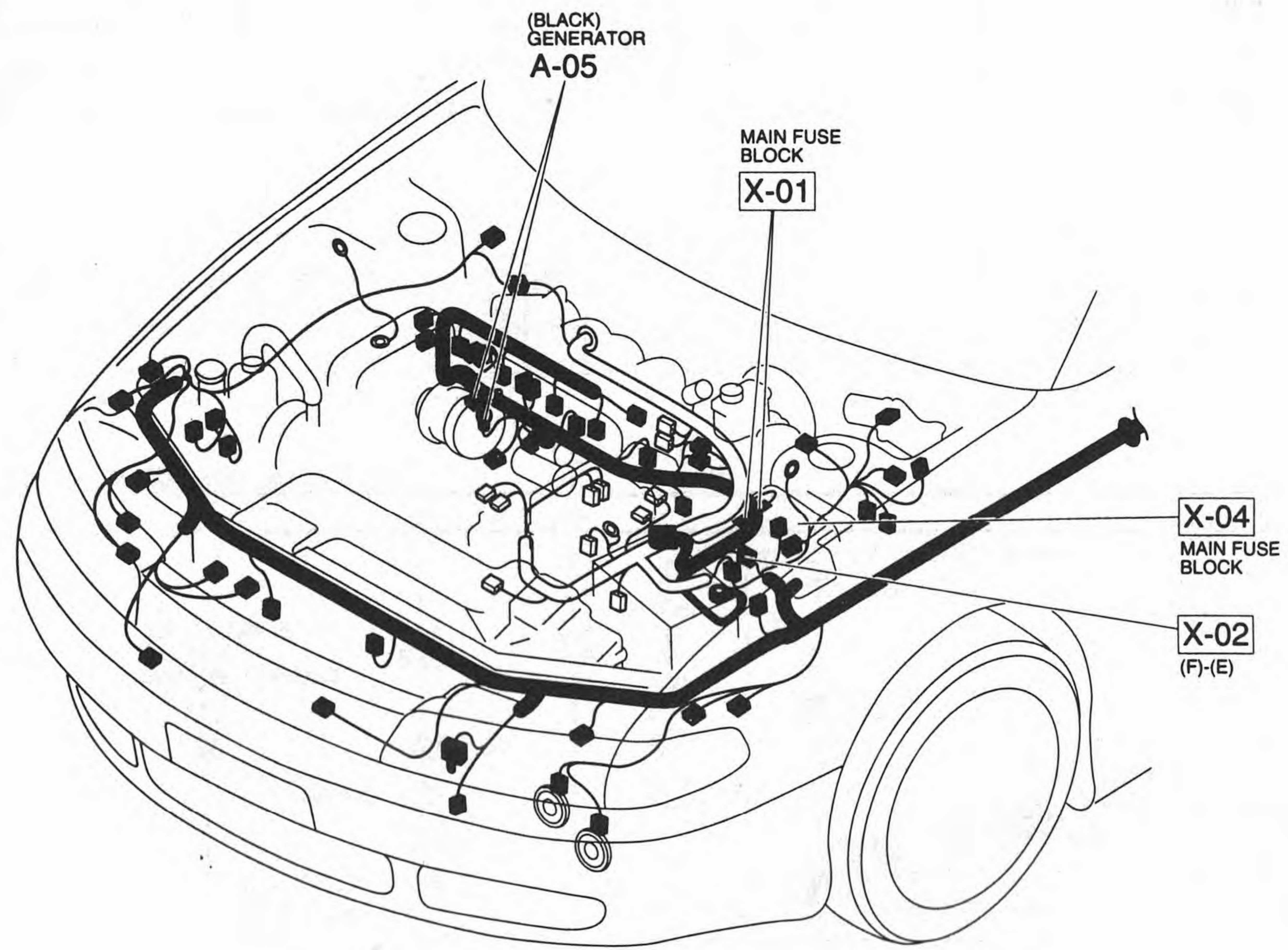

MAIN FUSE BLOCK

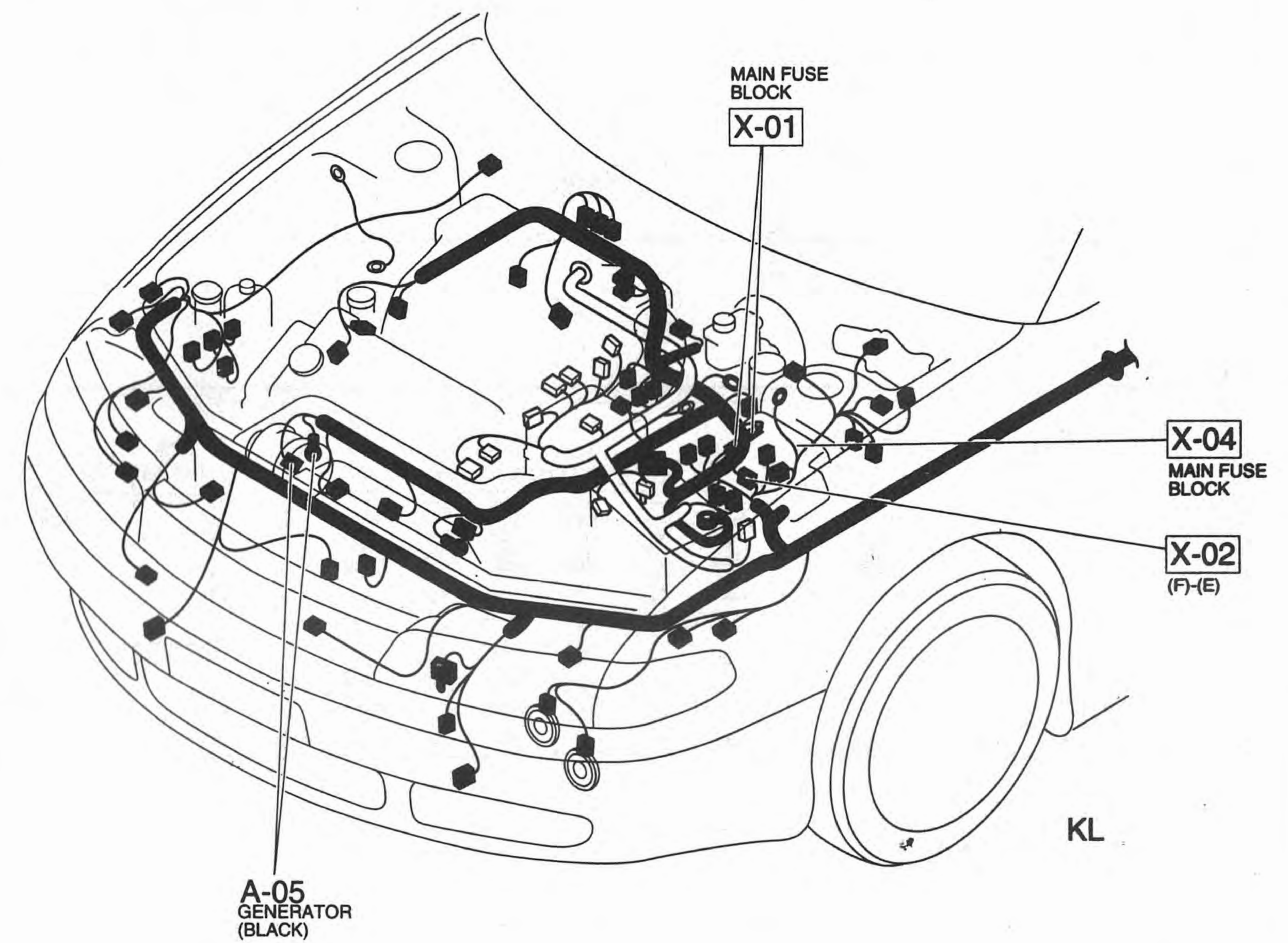
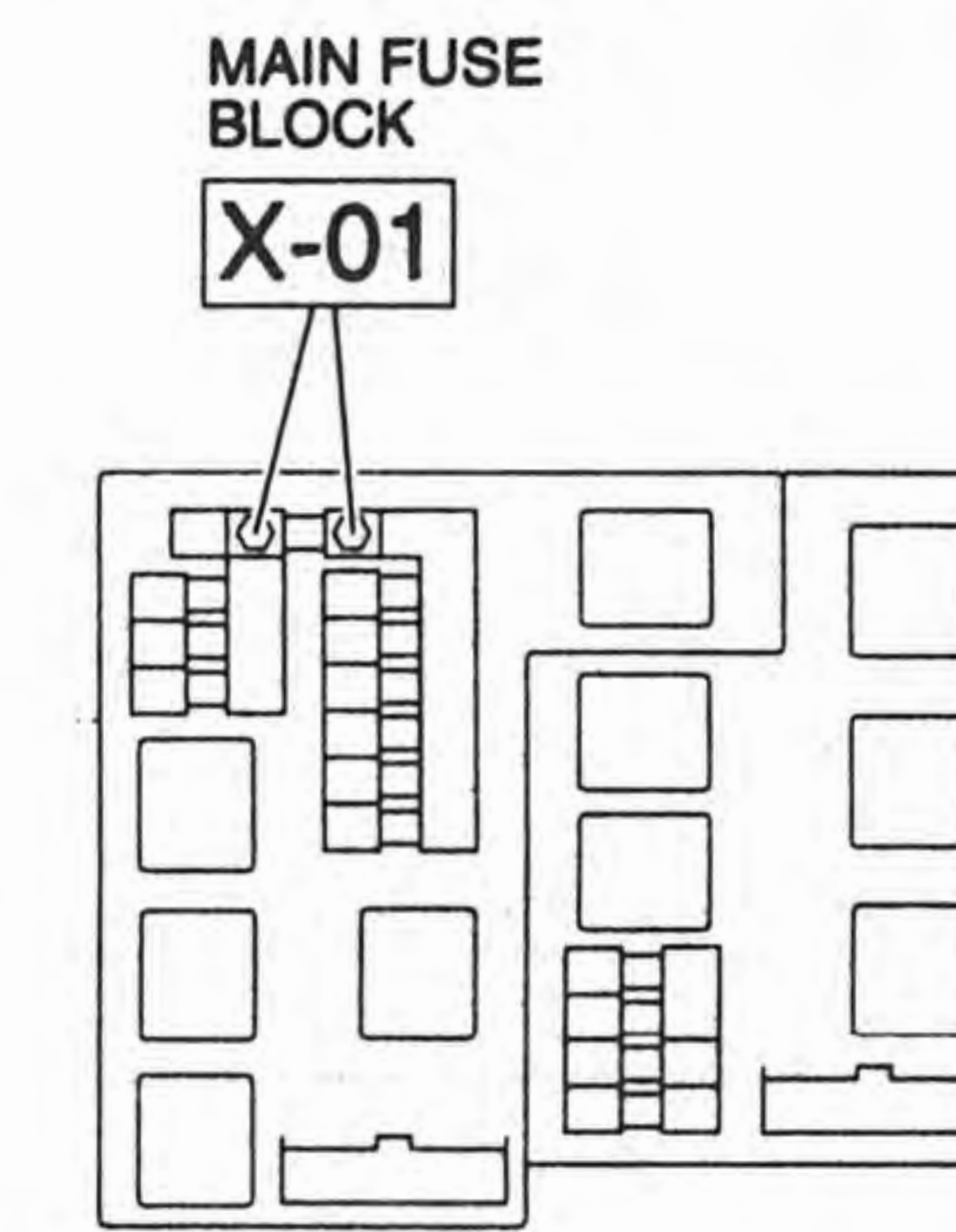

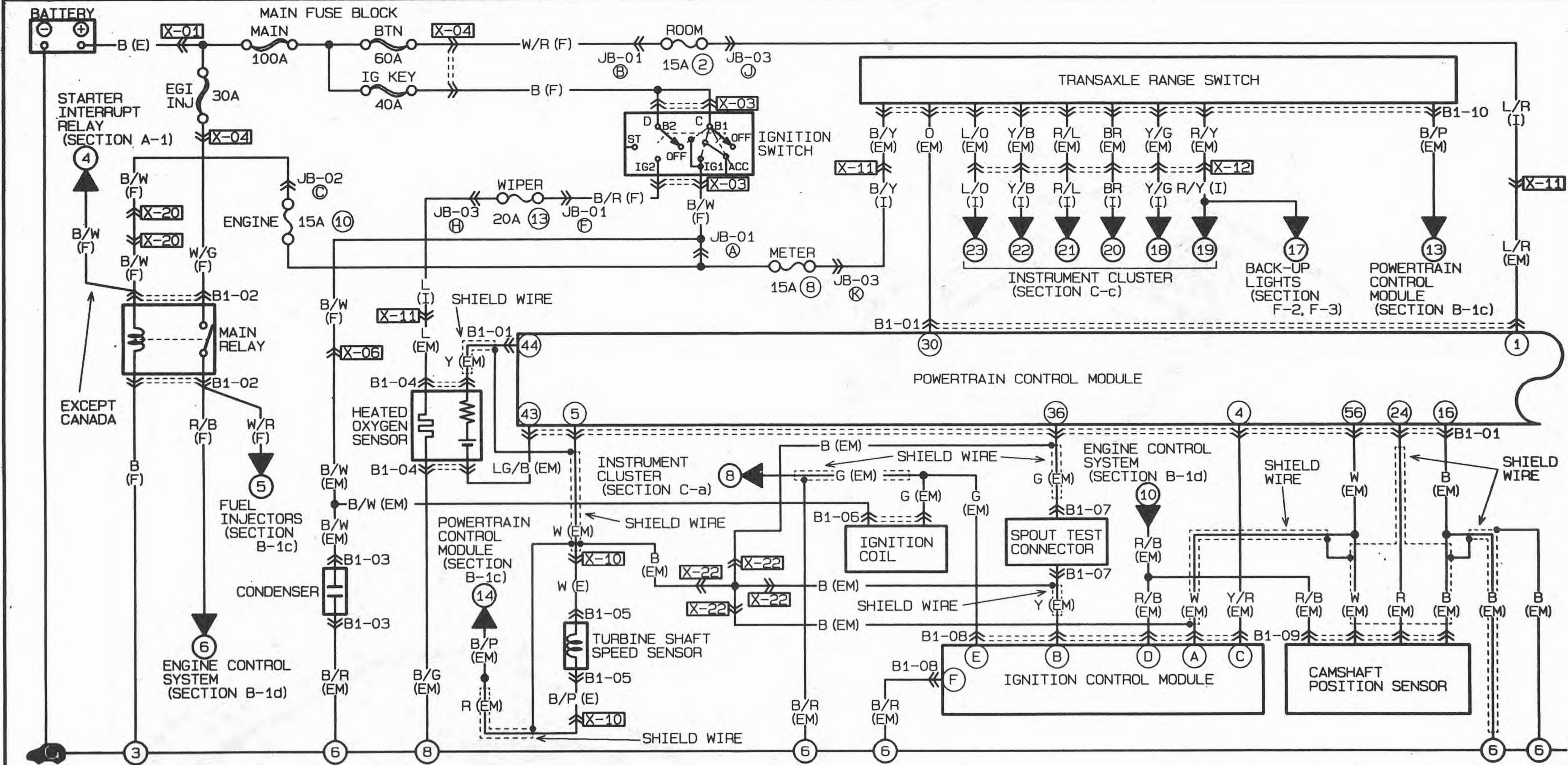

B1-01 POWERTRAIN CONTROL MODULE (EM)

20	19	18	17	16	15	14	13	12	11	10	9	8	7	6	5	4	3	2	1
*	*	*	L	B	*	Y/B	L/O	V/R	W/B	G/O	B/L	GY/R	O/G	R/B	W	Y/R	GY/L	W/G	L/R
40	39	38	37	36	35	34	33	32	31	30	29	28	27	26	25	24	23	22	21
B/G	L	GY	R/B	G	R/Y	BR/Y	W/L	LG/R	L/G	O	L/B	L/Y	R/G	G/L	Y/G	R	V	LG	GY/R
60	59	58	57	56	55	54	53	52	51	50	49	48	47	46	45	44	43	42	41
B/Y	L/W	R/W	R/B	W	BR/W	G/W	GY/B	G/R	P	P/B	BR/L	LG/W	P/L	B/P	*	Y	LG/B	GY/G	BR/B

B1-02 MAIN RELAY (F)

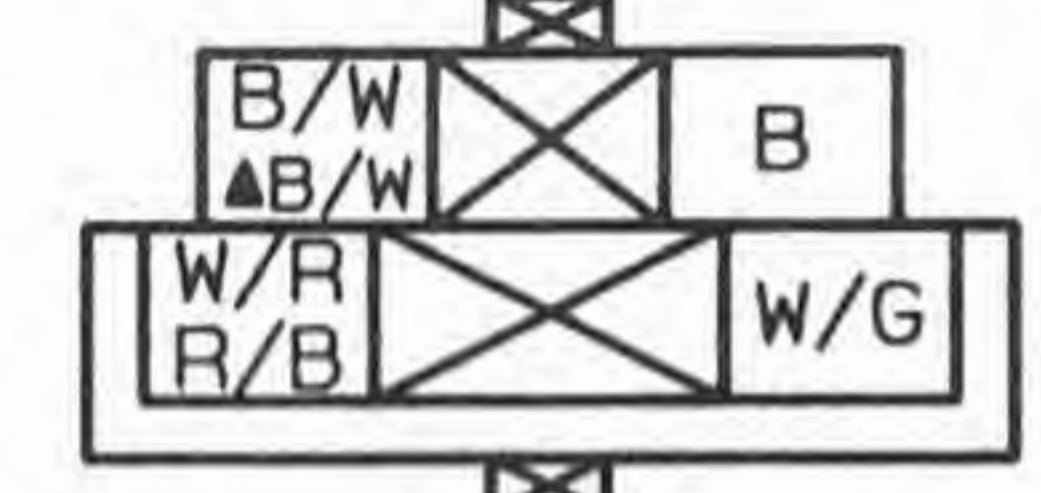

B1-03 CONDENSER (EM)

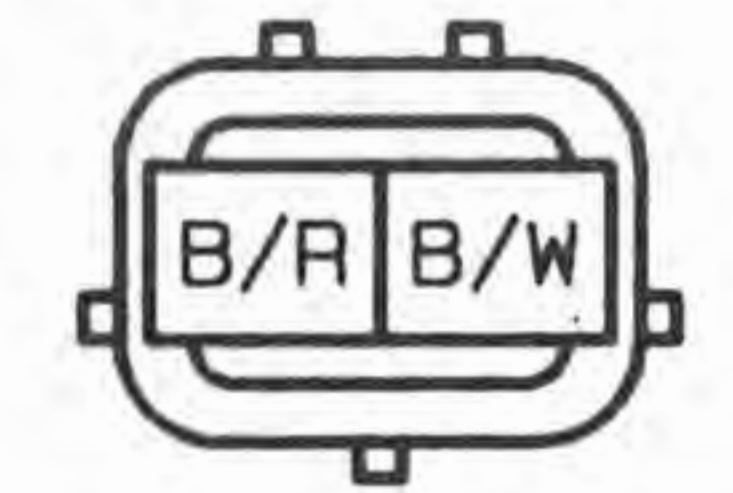

B1-04 HEATED OXYGEN SENSOR (EM)

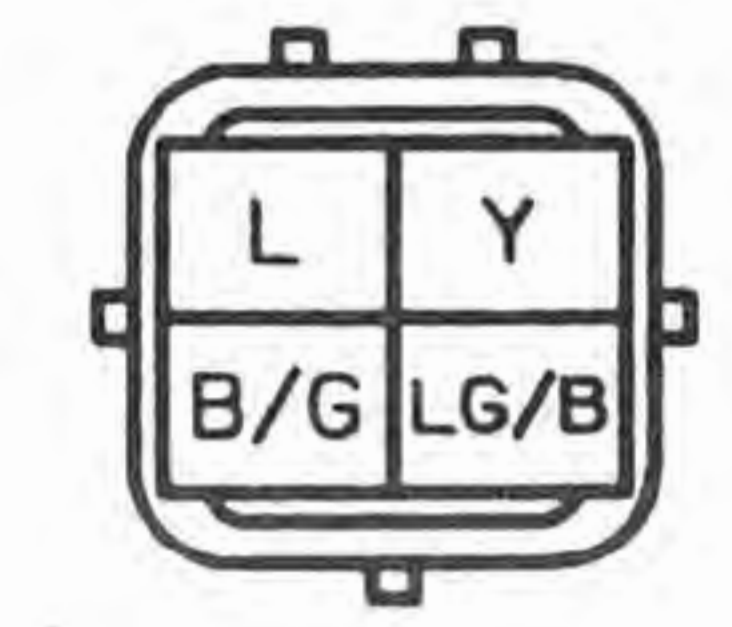

B1-05 TURBINE SHAFT SPEED SENSOR (E)

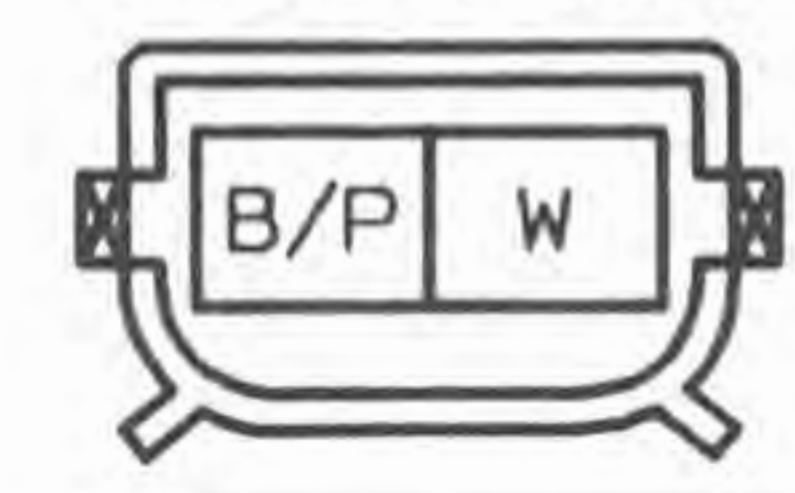

B1-06 IGNITION COIL (EM)

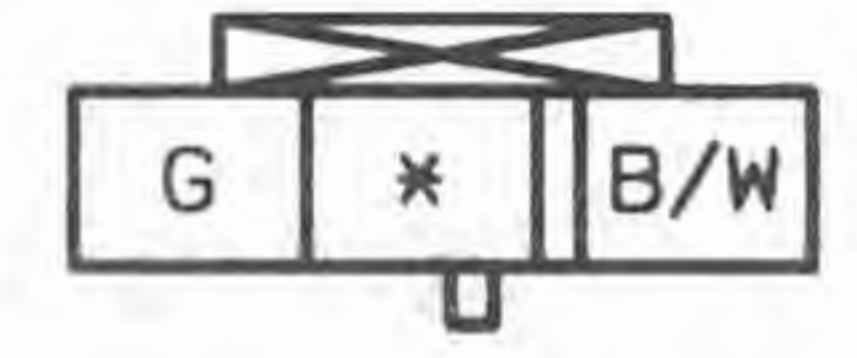

B1-07 SPOUT TEST CONNECTOR (EM)



B1-08 IGNITION CONTROL MODULE (EM)

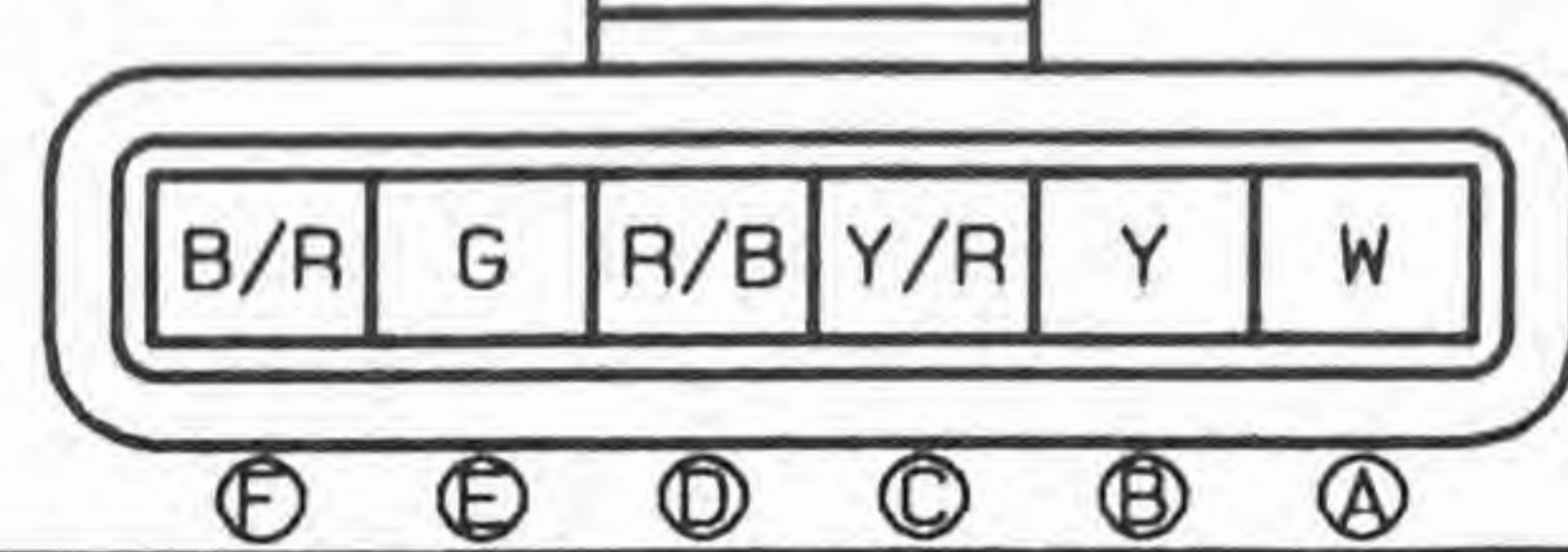

B1-09 CAMSHAFT POSITION SENSOR (EM)

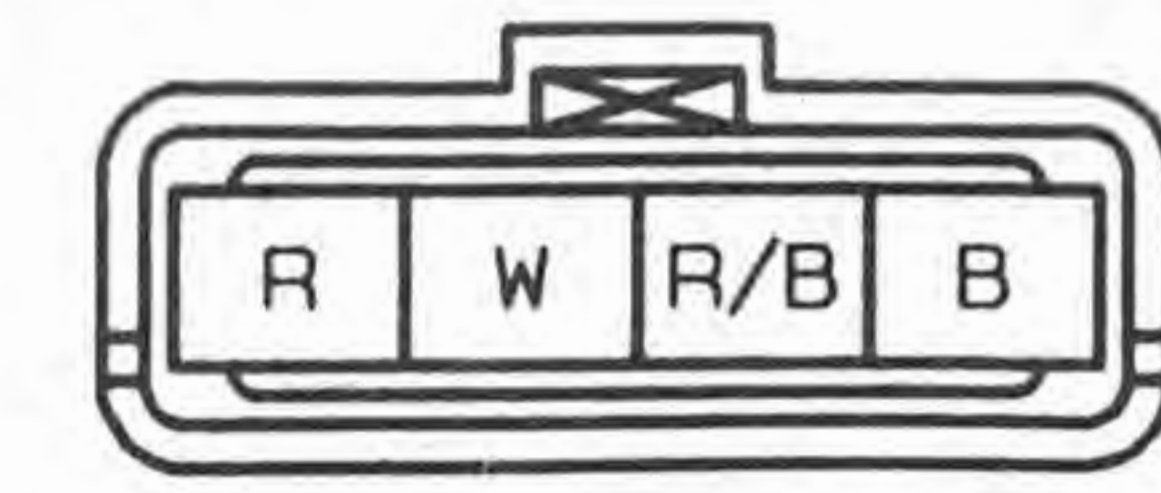

B1-10 TRANSAXLE RANGE SWITCH (EM)

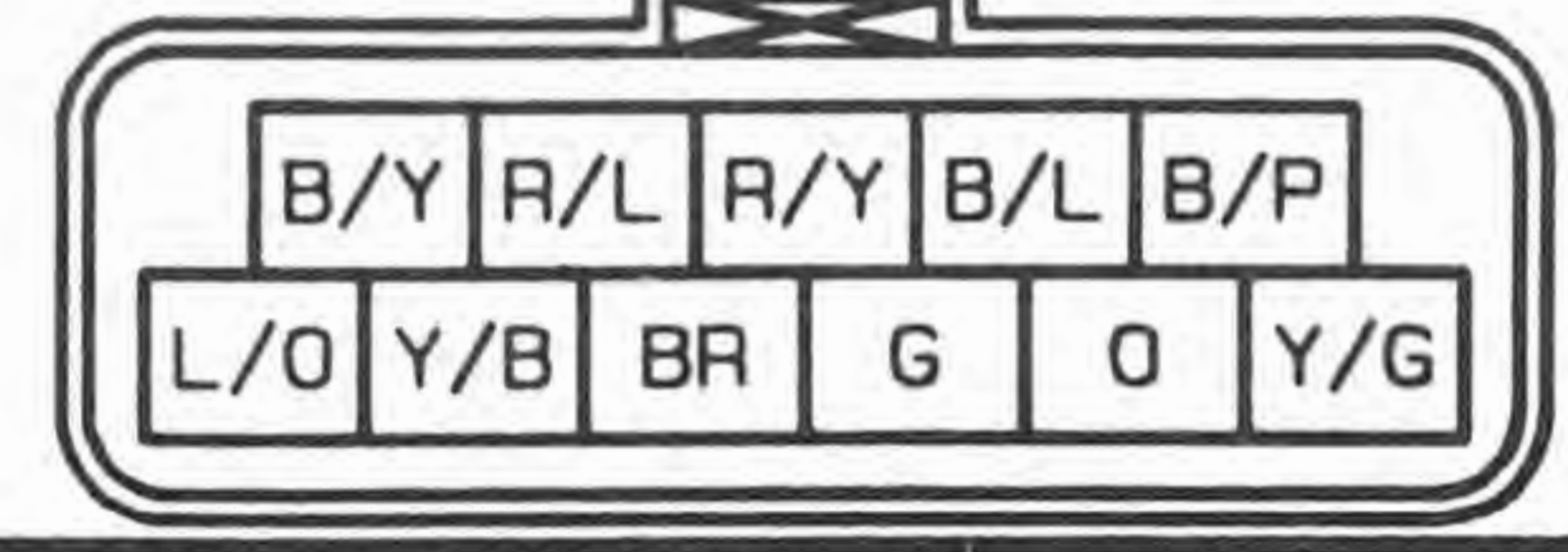

B-1a

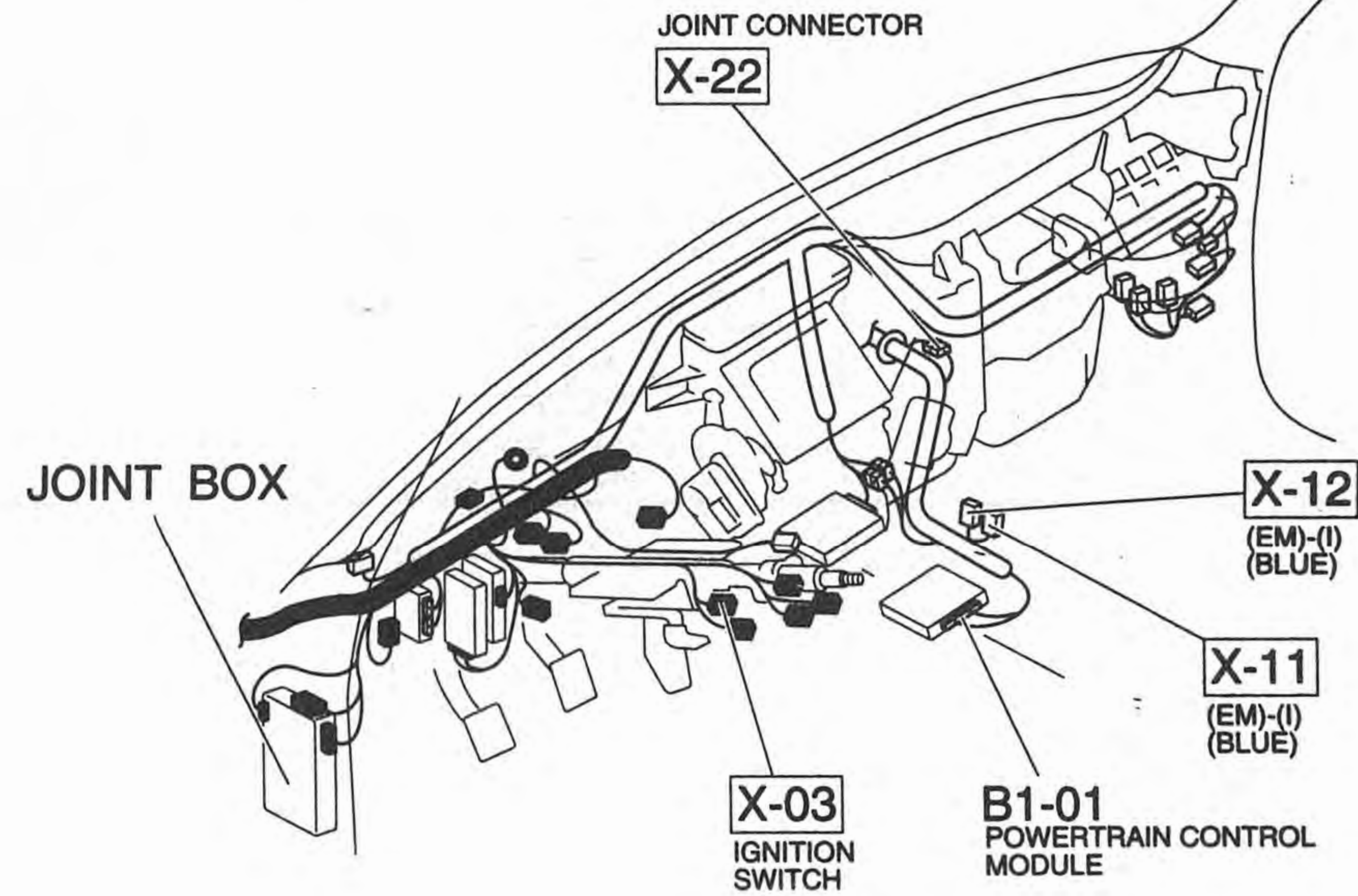
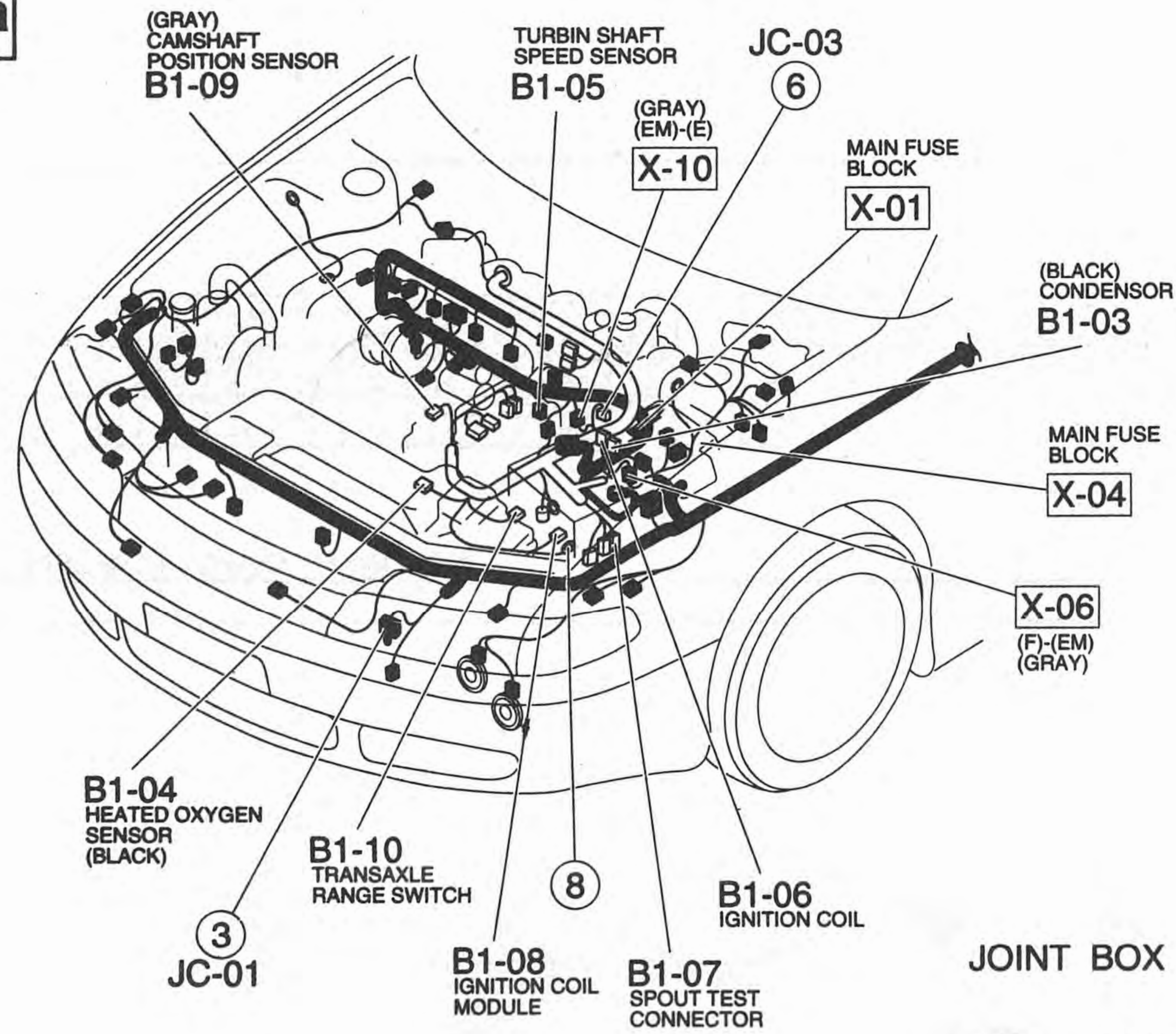

JOINT BOX

MAIN FUSE BOX

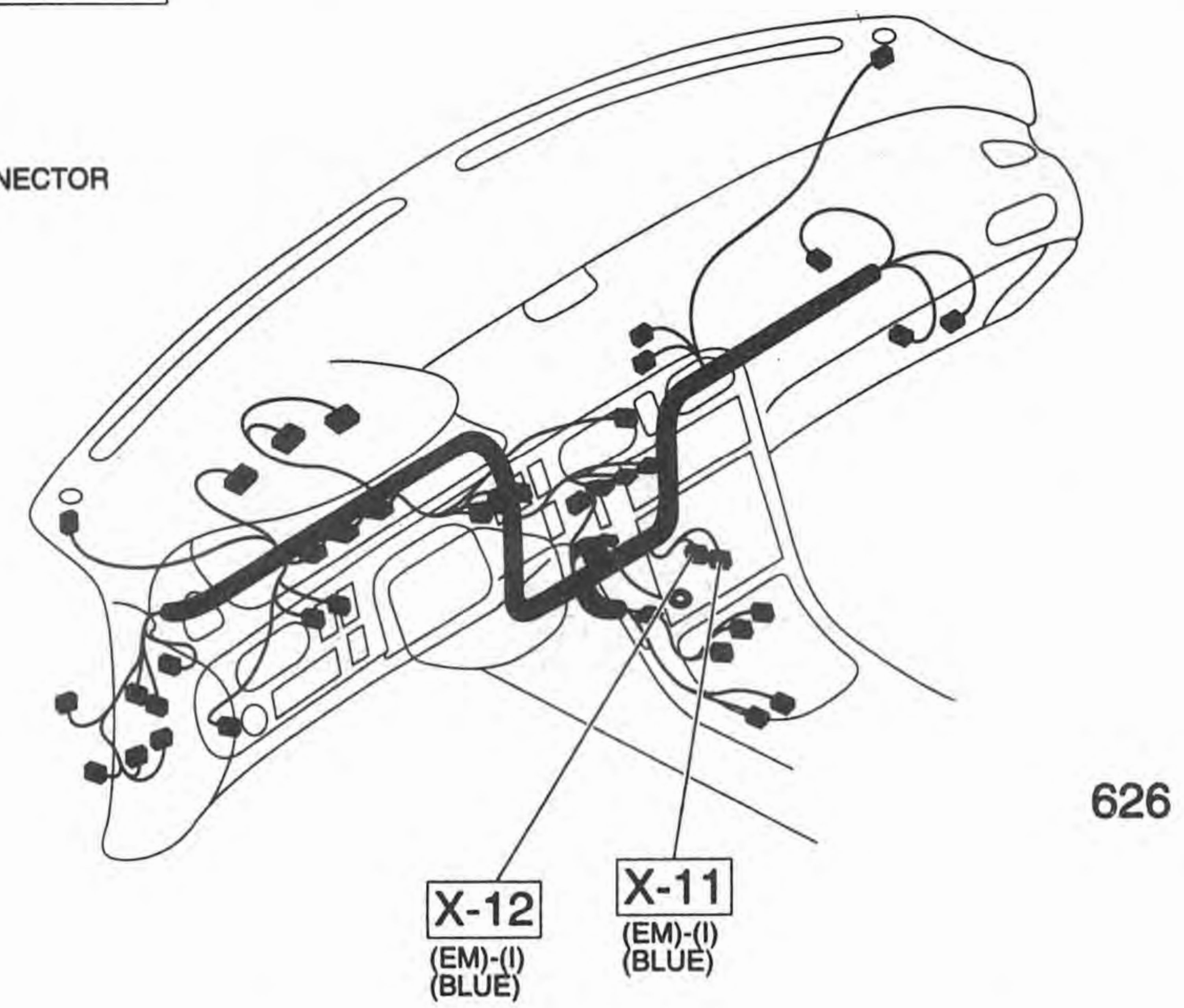
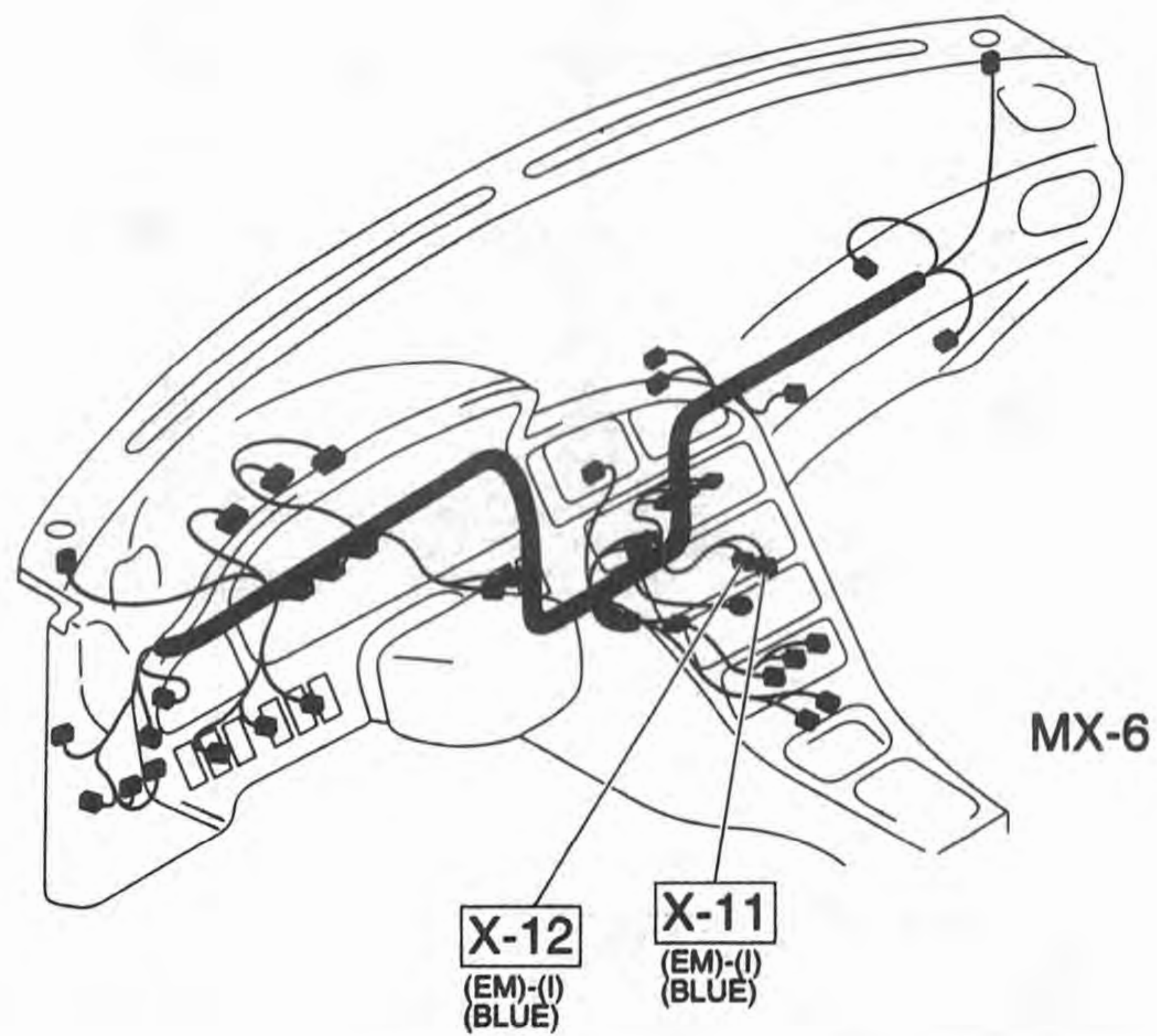
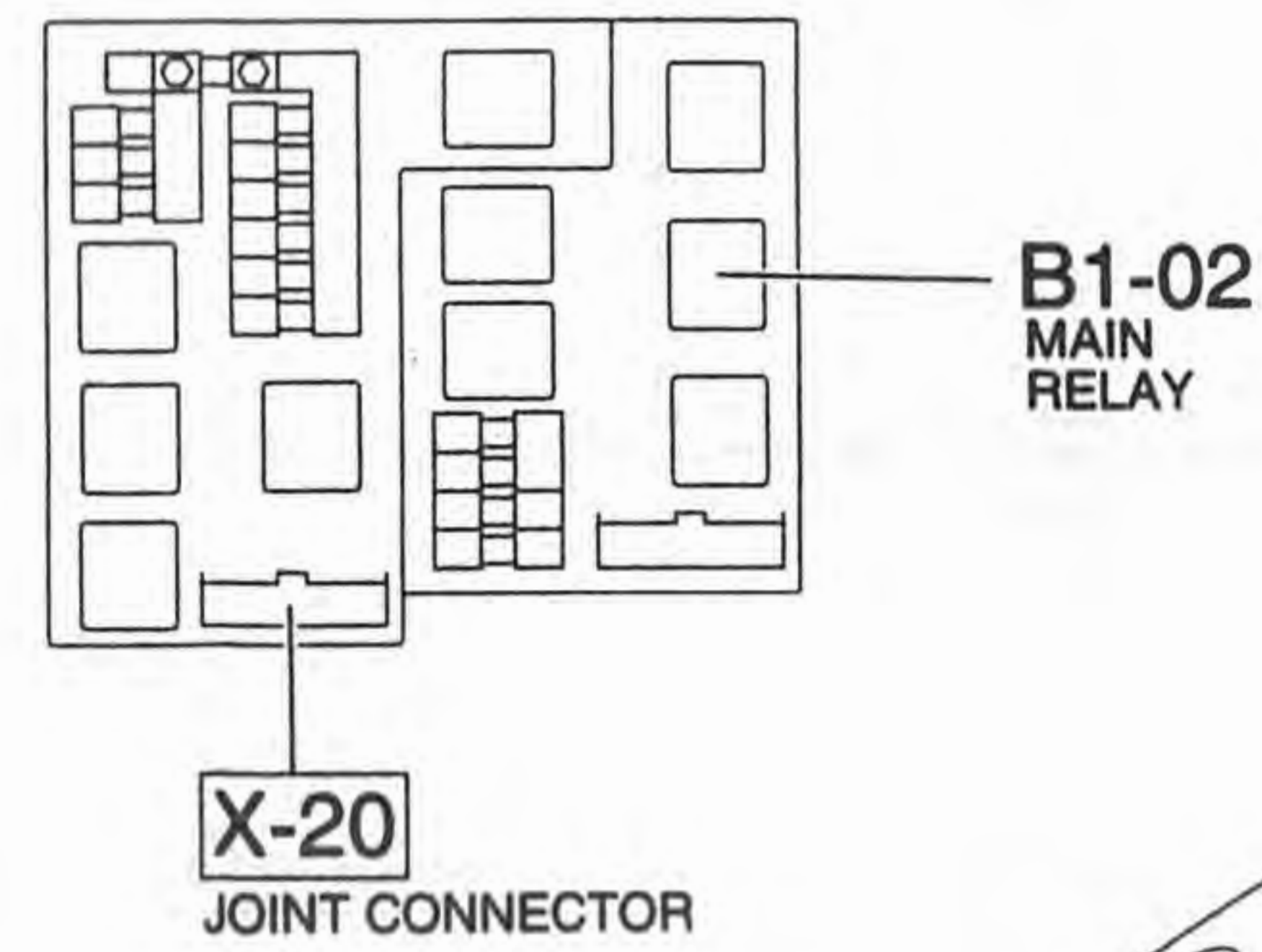
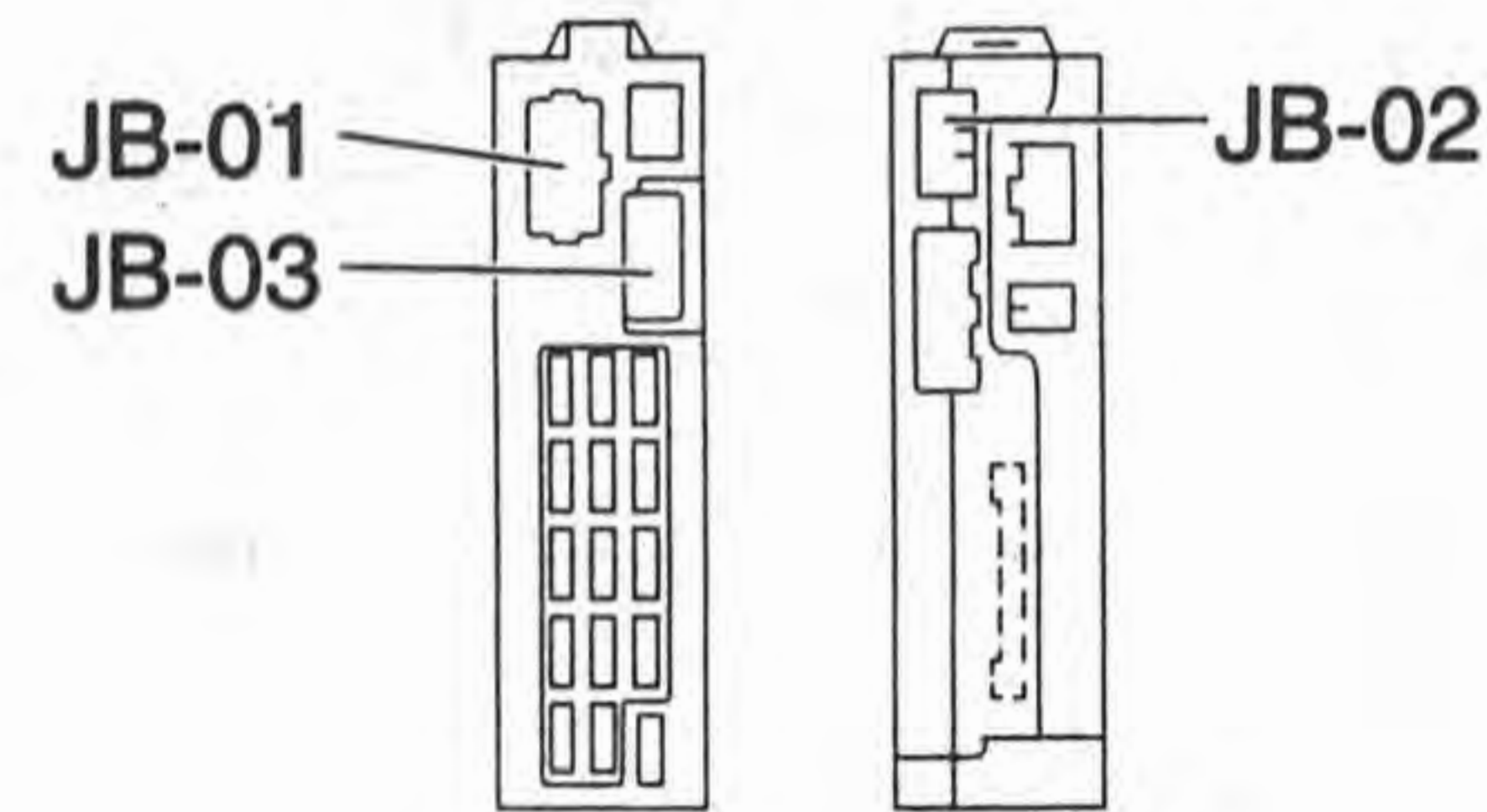

Z WIRING DIAGRAM

B-1b

FS ATX

■ EC-AT CONTROL SYSTEM
■ ENGINE CONTROL SYSTEM

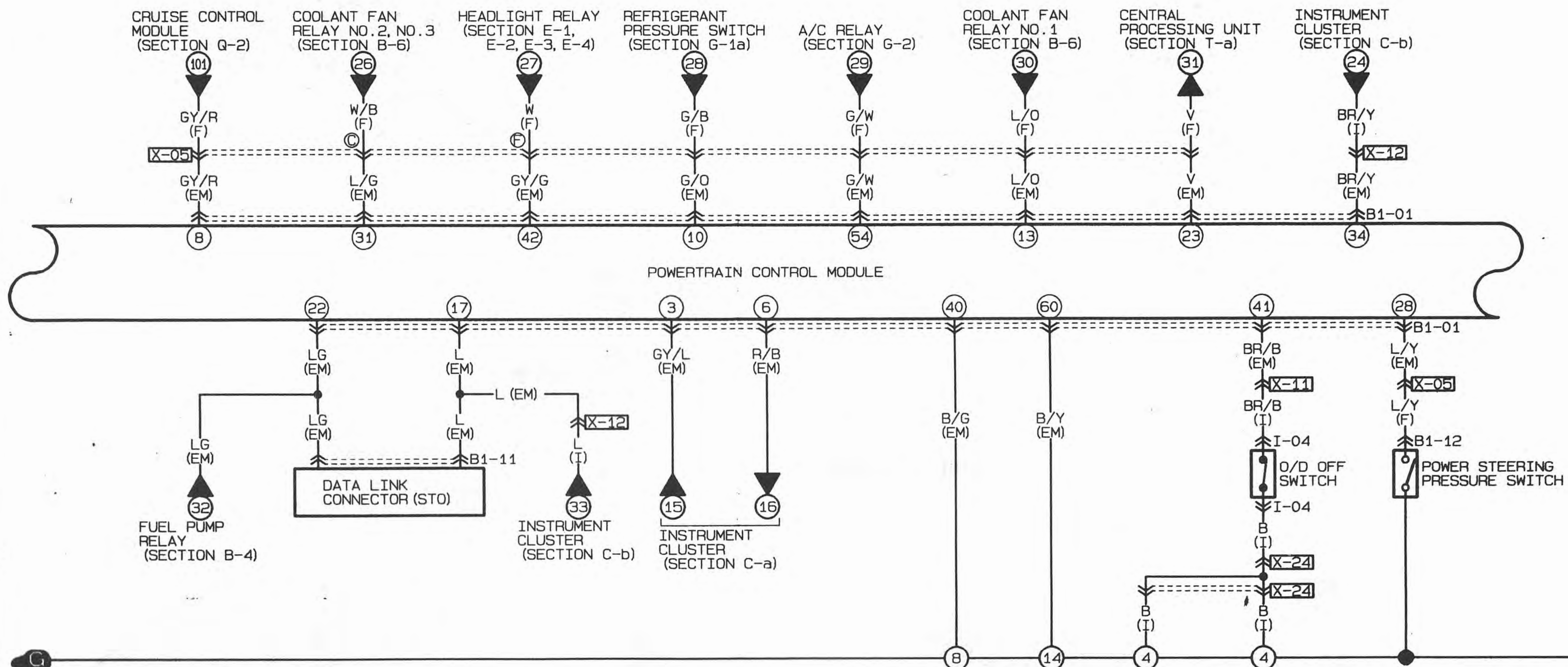

B1-01 POWERTRAIN CONTROL MODULE (EM)

20	19	18	17	16	15	14	13	12	11	10	9	8	7	6	5	4	3	2	1
*	*	*	L	B	*	Y/B	L/O	V/R	W/B	G/O	B/L	GY/R	O/G	R/B	W	Y/R	GY/L	W/G	L/R
40	39	38	37	36	35	34	33	32	31	30	29	28	27	26	25	24	23	22	21
B/G	L	GY	R/B	G	R/Y	BR/Y	W/L	LG/R	L/G	O	L/B	L/Y	R/G	G/L	Y/G	R	V	LG	GY/R
60	59	58	57	56	55	54	53	52	51	50	49	48	47	46	45	44	43	42	41
B/Y	L/W	R/W	R/B	W	BR/W	G/W	GY/B	G/R	P	P/B	BR/L	LG/W	P/L	B/P	*	Y	LG/B	GY/G	BR/B

B1-11 DATA LINK CONNECTOR (STO) (EM)

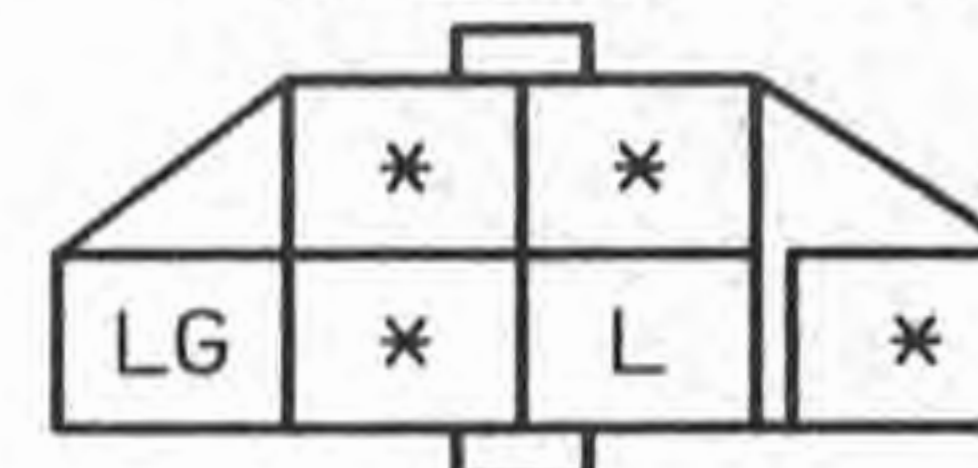

B1-12 POWER STEERING PRESSURE SWITCH (F)



I-04 O/D OFF SWITCH (I)

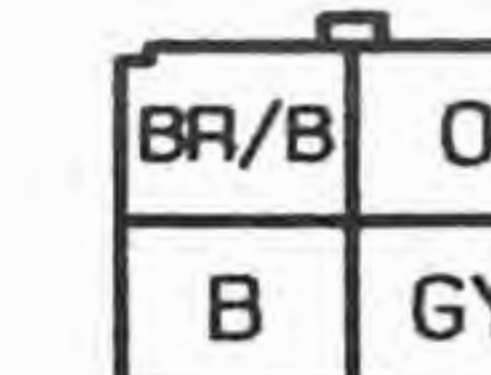

B-1b

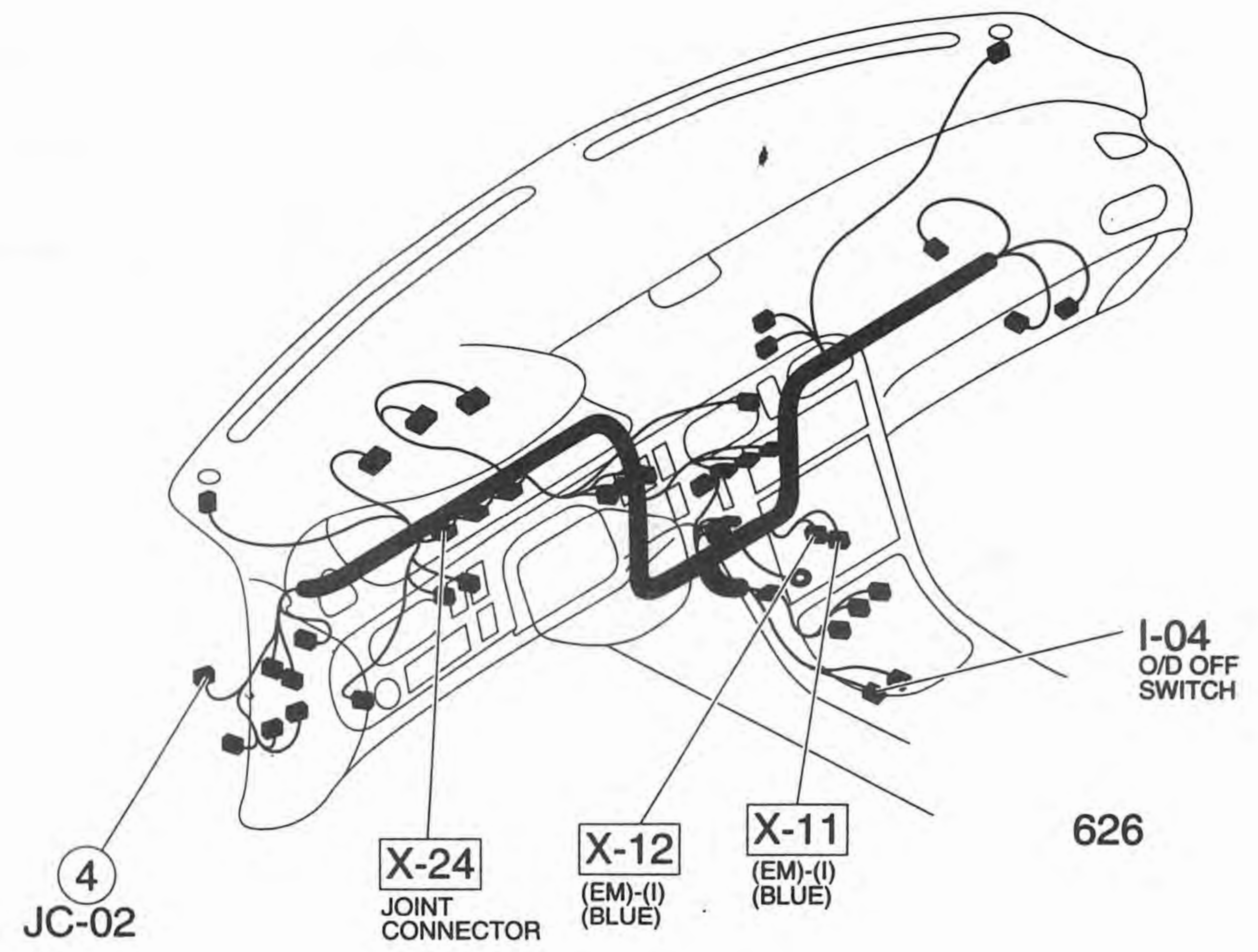
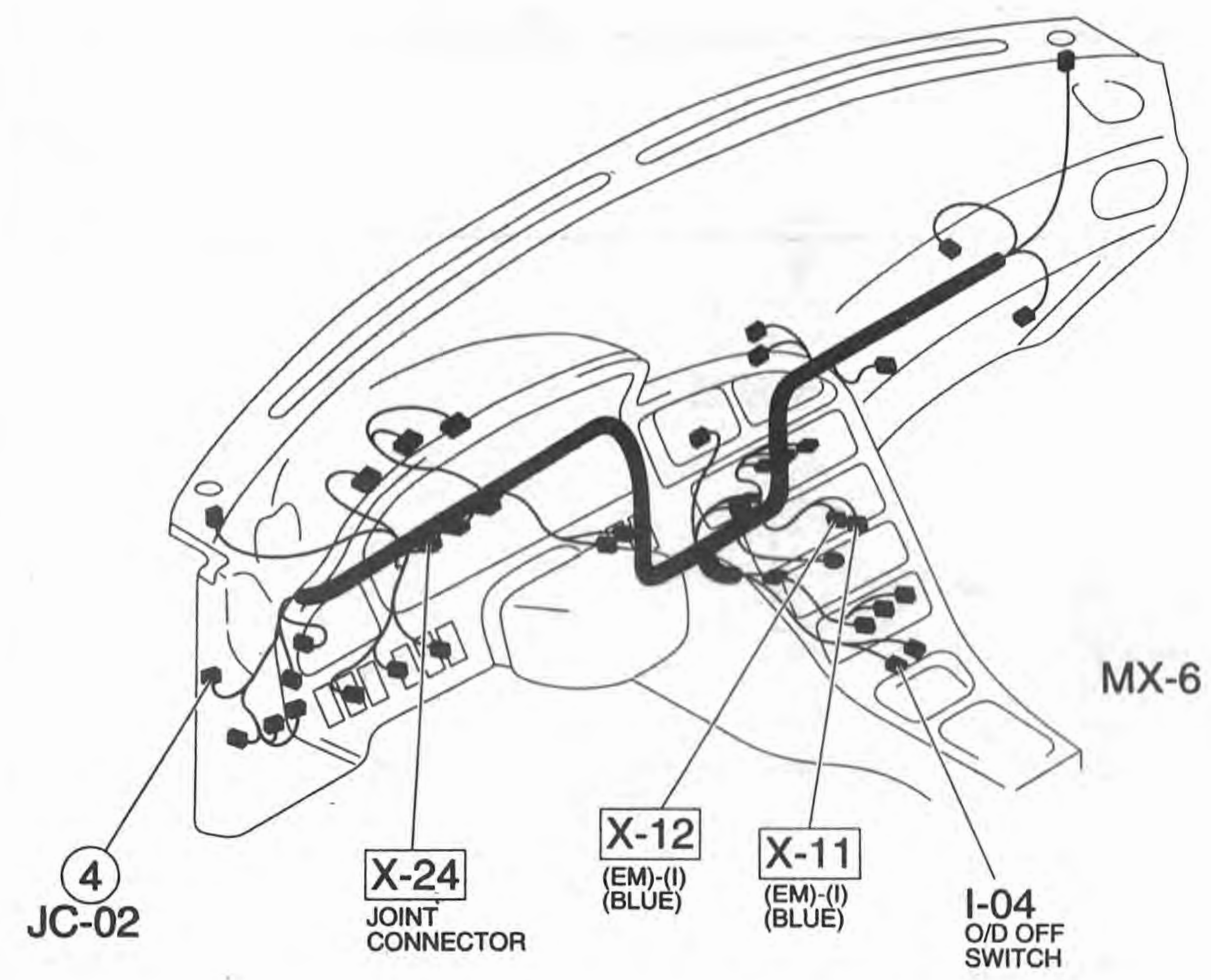
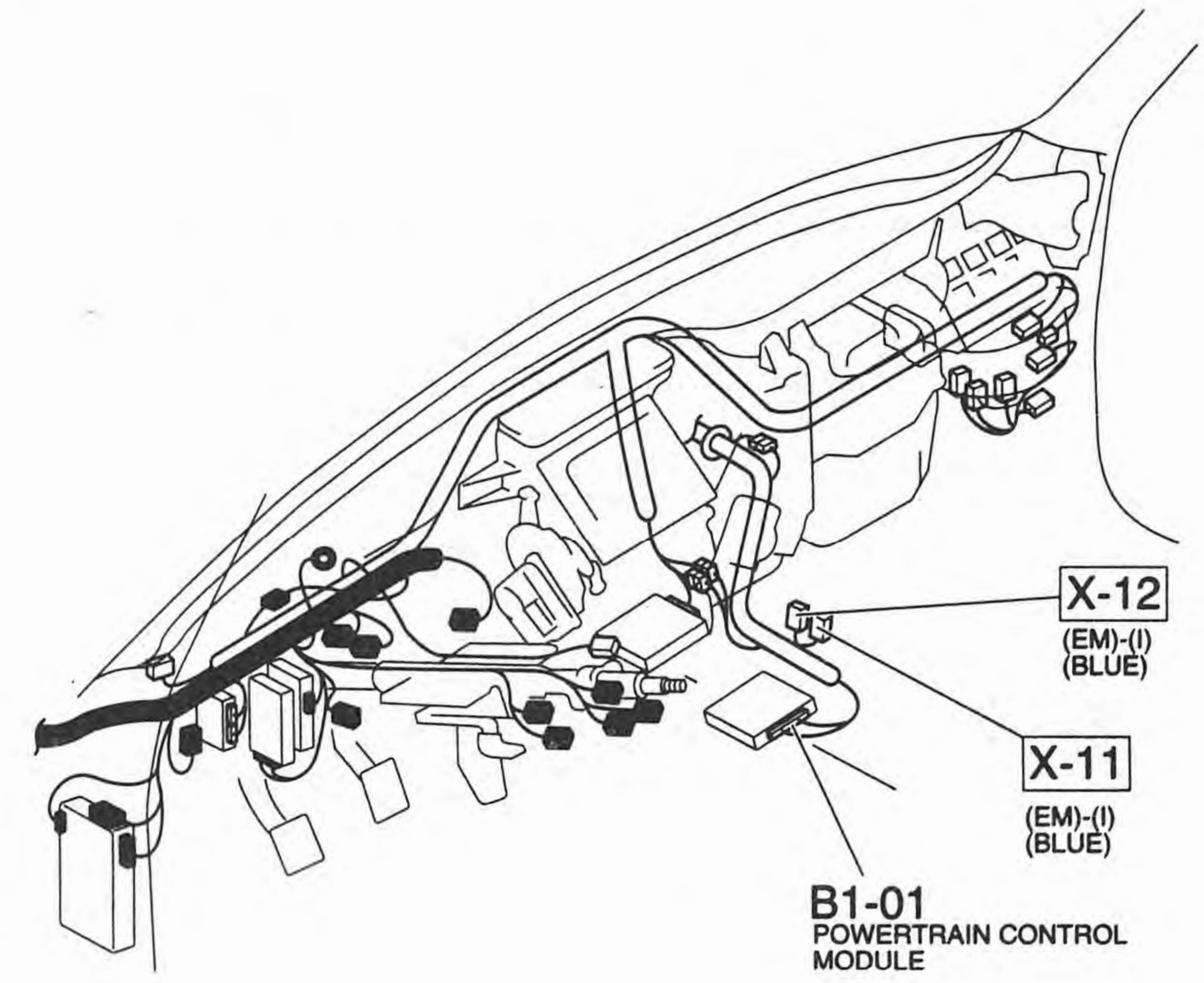
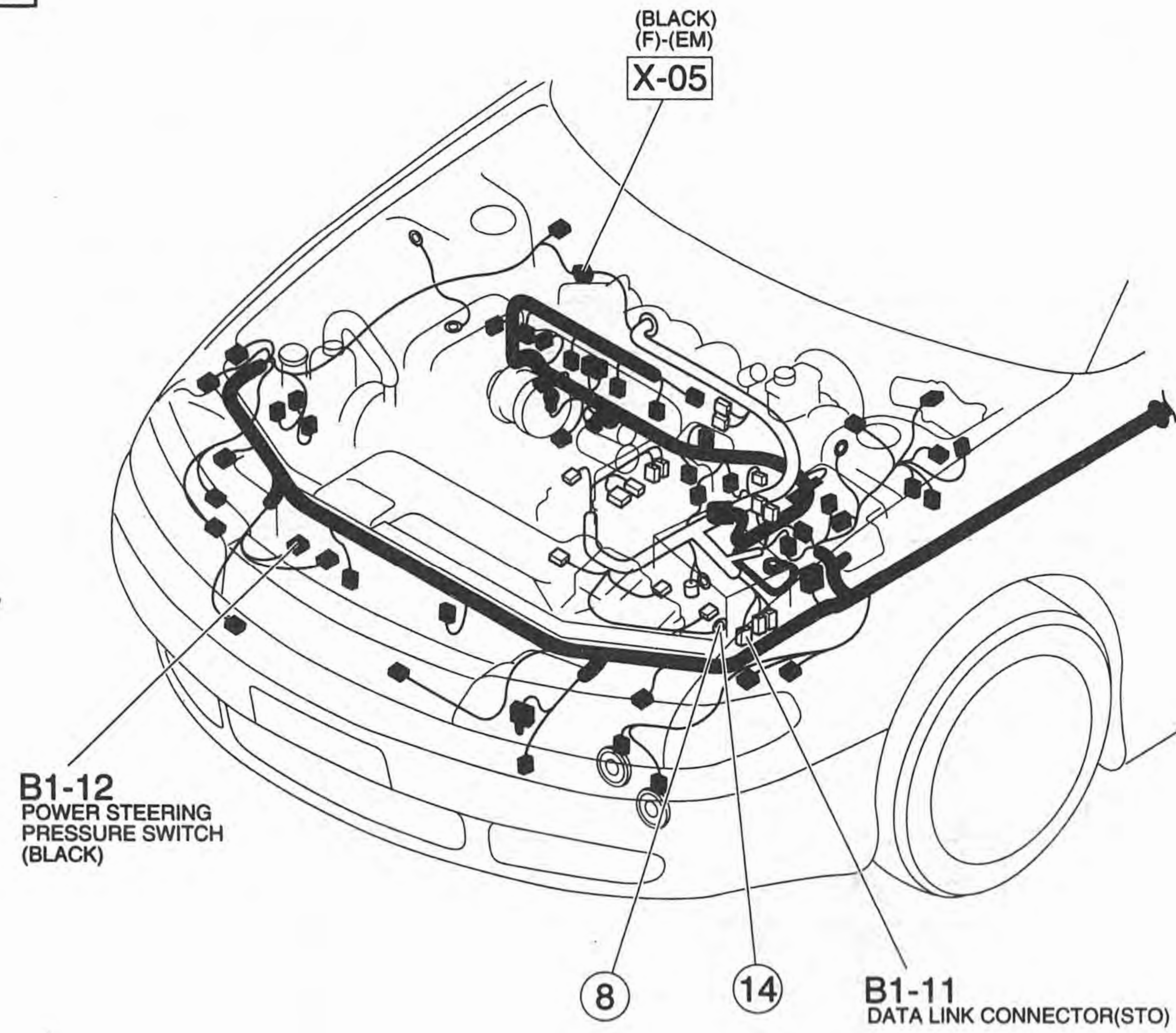

Z WIRING DIAGRAM

B-1c FS ATX ■ EC-AT CONTROL SYSTEM ■ ENGINE CONTROL SYSTEM

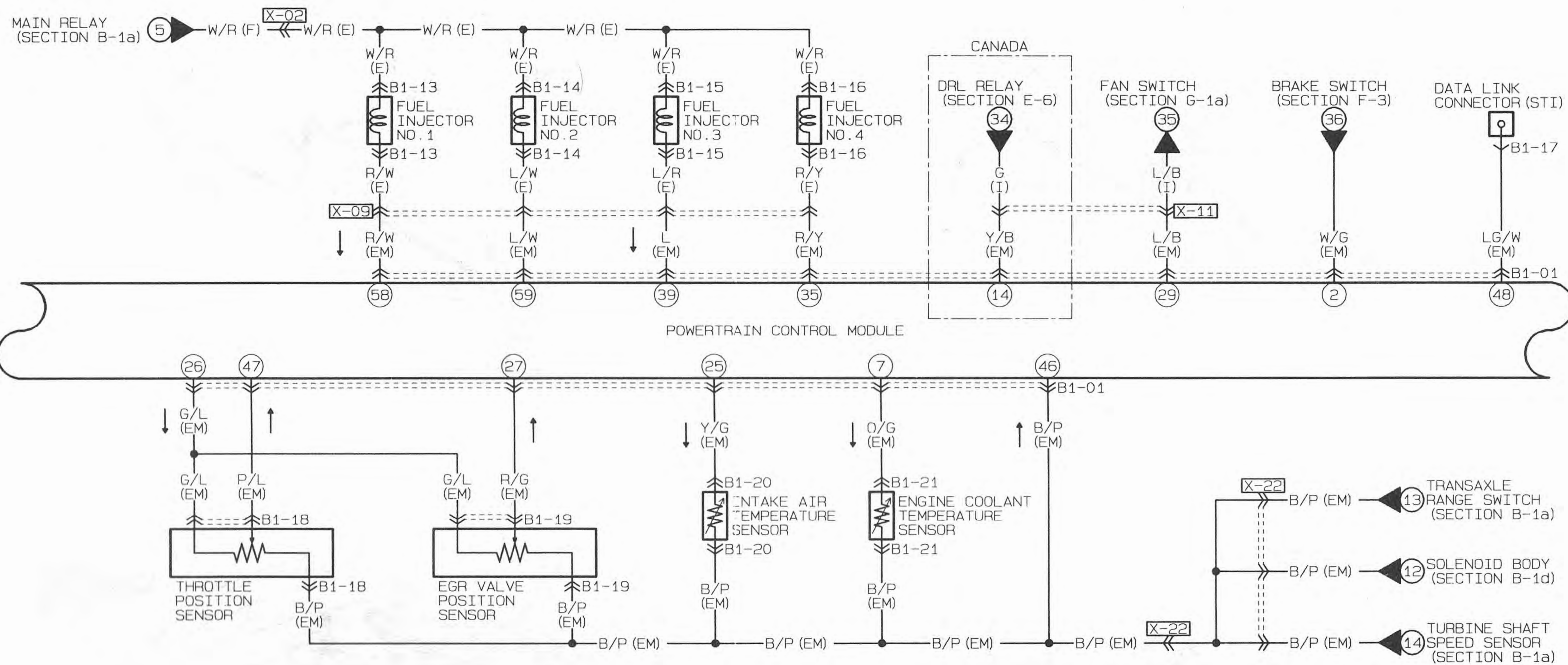

B1-01 POWERTRAIN CONTROL MODULE (EM)

20	19	18	17	16	15	14	13	12	11		10	9	8	7	6	5	4	3	2	1
*	*	*	L	B	*	Y/B	L/O	V/R	W/B		G/O	B/L	GY/R	O/G	R/B	W	Y/R	GY/L	W/G	L/R
40	39	38	37	36	35	34	33	32	31		30	29	28	27	26	25	24	23	22	21
B/G	L	GY	R/B	G	R/Y	BR/Y	W/L	LG/R	L/G		O	L/B	L/Y	R/G	G/L	Y/G	R	V	LG	GY/R
60	59	58	57	56	55	54	53	52	51		50	49	48	47	46	45	44	43	42	41
B/Y	L/W	R/W	R/B	W	BR/W	G/W	GY/B	G/R	P		P/B	BR/L	LG/W	P/L	B/P	*	Y	LG/B	GY/G	BR/B

B1-13 FUEL INJECTOR NO. 1 (E)



B1-14 FUEL INJECTOR NO. 2 (E)

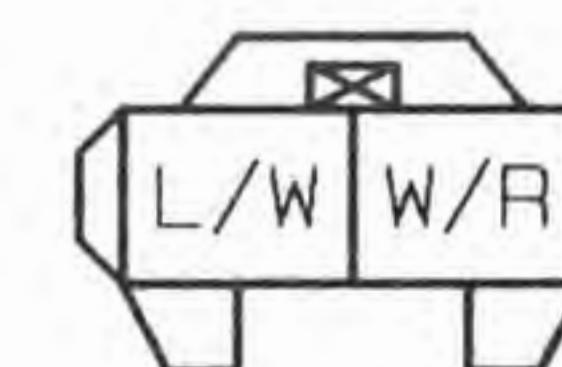

B1-15 FUEL INJECTOR NO. 3 (E)



B1-16 FUEL INJECTOR NO. 4 (E)



B1-17 DATA LINK CONNECTOR (STI) (EM)

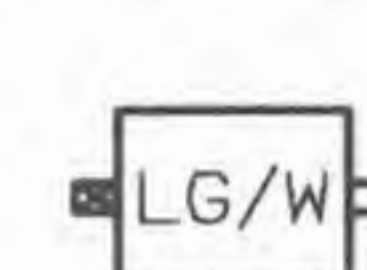

B1-18 THROTTLE POSITION SENSOR (EM)

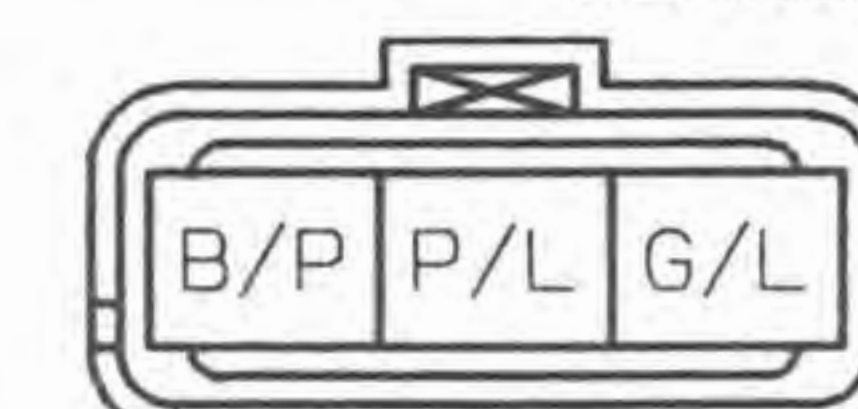

B1-19 EGR VALVE POSITION SENSOR (EM)

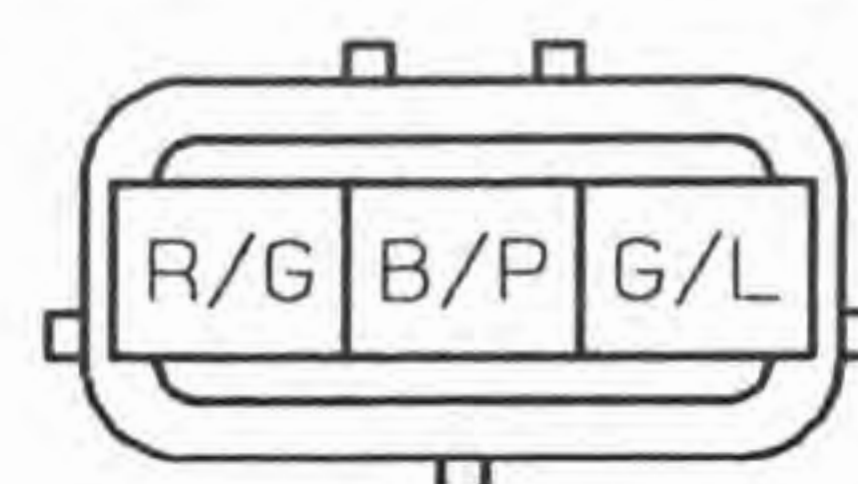

B1-20 INTAKE AIR TEMPERATURE SENSOR (EM)

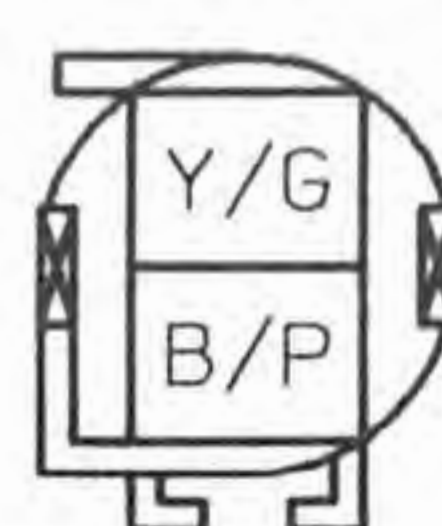

B1-21 ENGINE COOLANT TEMPERATURE SENSOR (EM)

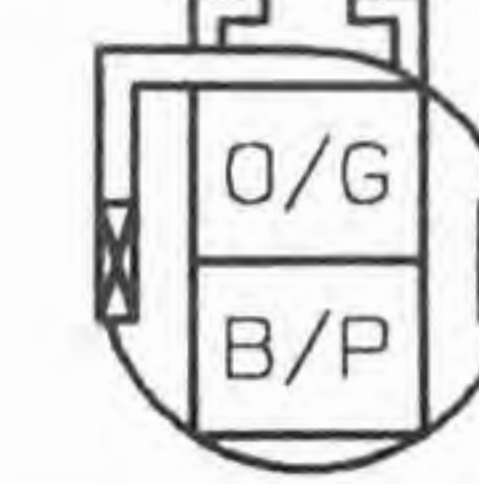

B-1c

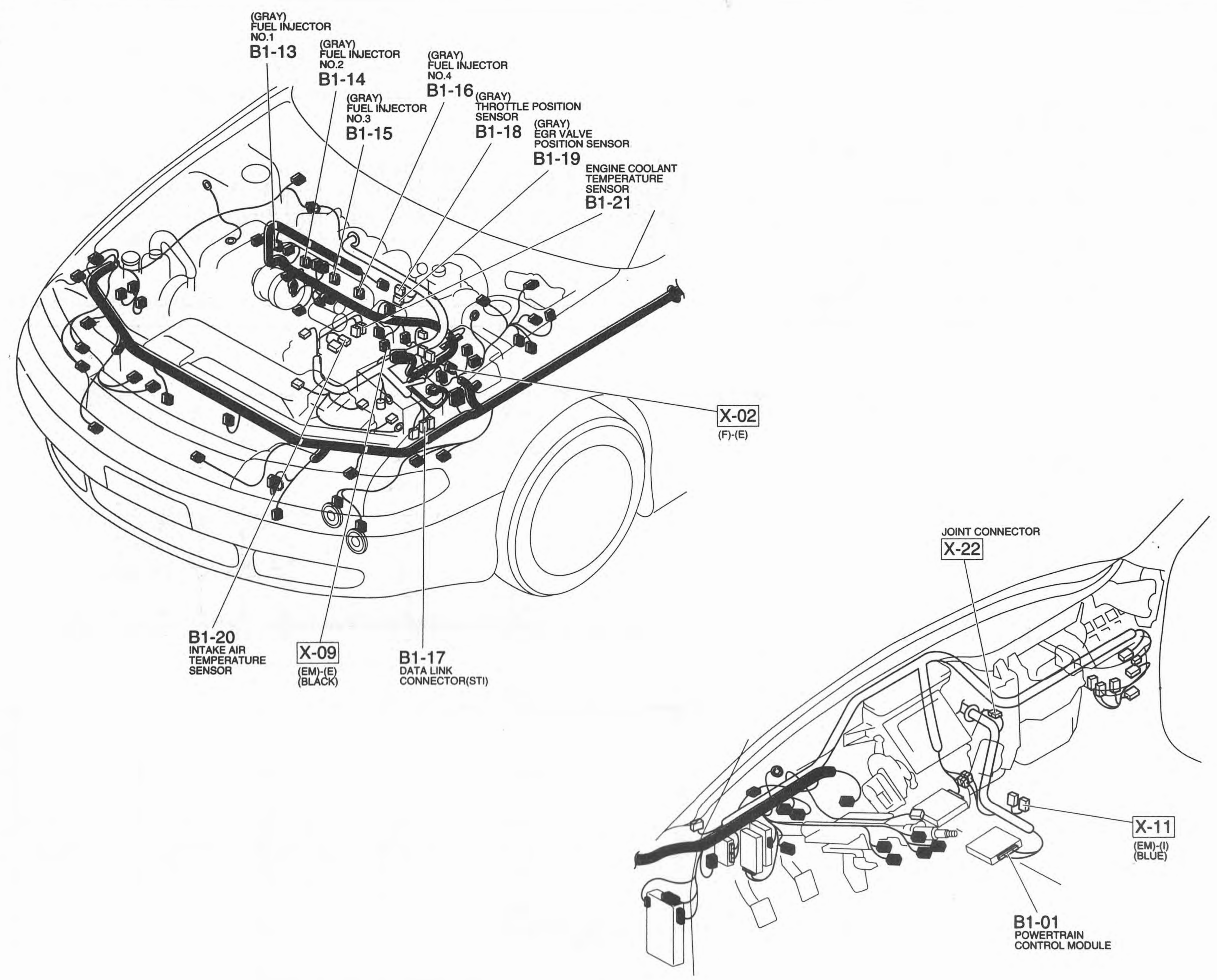

Z WIRING DIAGRAM

B-1d FS ATX ■ EC-AT CONTROL SYSTEM ■ ENGINE CONTROL SYSTEM

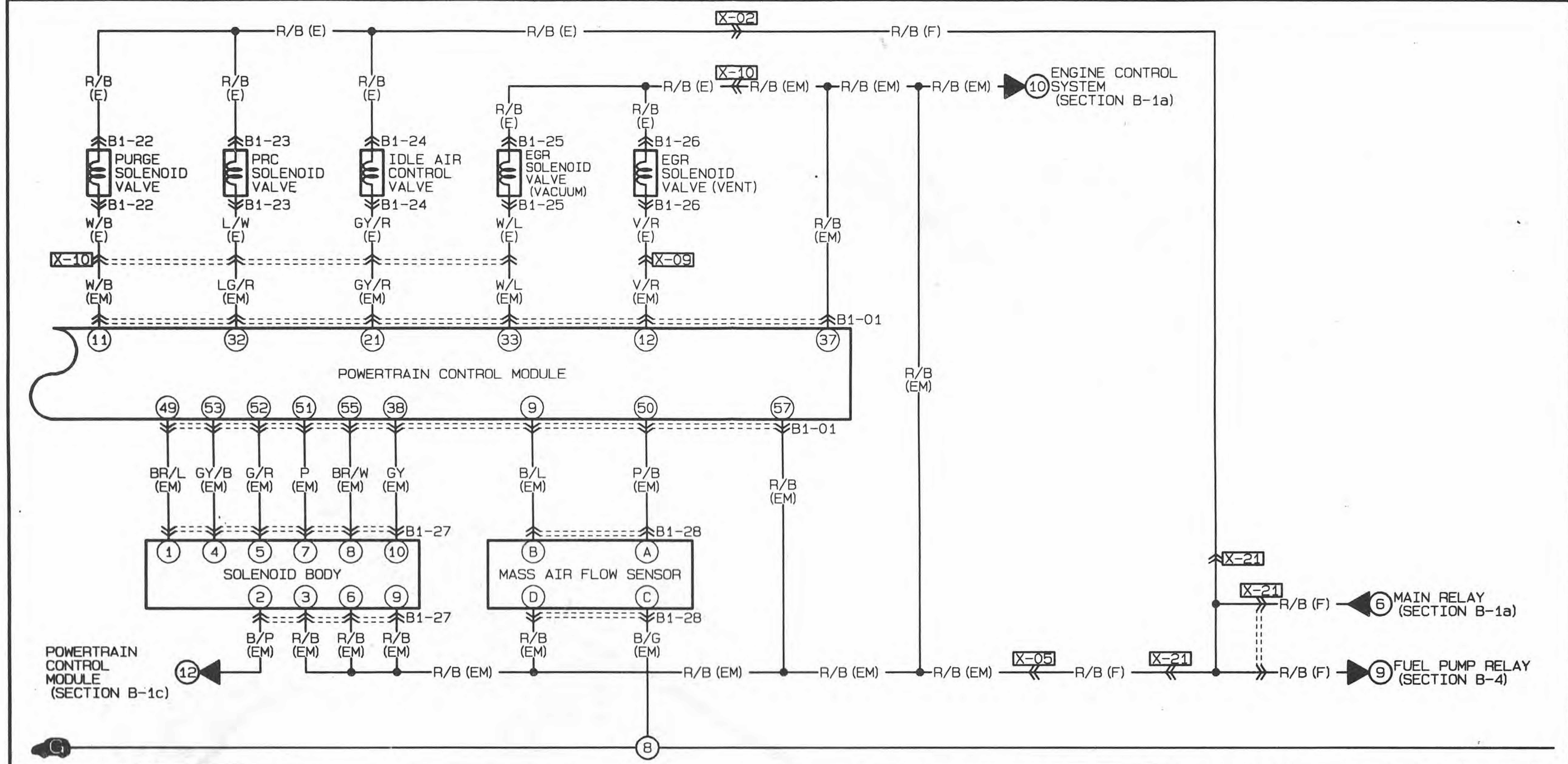

B1-01 POWERTRAIN CONTROL MODULE (EM)

20	19	18	17	16	15	14	13	12	11	10	9	8	7	6	5	4	3	2	1
*	*	*	L	B	*	Y/B	L/O	V/R	W/B	G/O	B/L	GY/R	O/G	R/B	W	Y/R	GY/L	W/G	L/R
40	39	38	37	36	35	34	33	32	31	30	29	28	27	26	25	24	23	22	21
B/G	L	GY	R/B	G	R/Y	BR/Y	W/L	LG/R	L/G	D	L/B	L/Y	R/G	G/L	Y/G	R	V	LG	GY/R
60	59	58	57	56	55	54	53	52	51	50	49	48	47	46	45	44	43	42	41
B/Y	L/W	R/W	R/B	W	BR/W	G/W	GY/B	G/R	P	P/B	BR/L	LG/W	P/L	B/P	*	Y	LG/B	GY/G	BR/B

B1-22 PURGE SOLENOID VALVE (E)

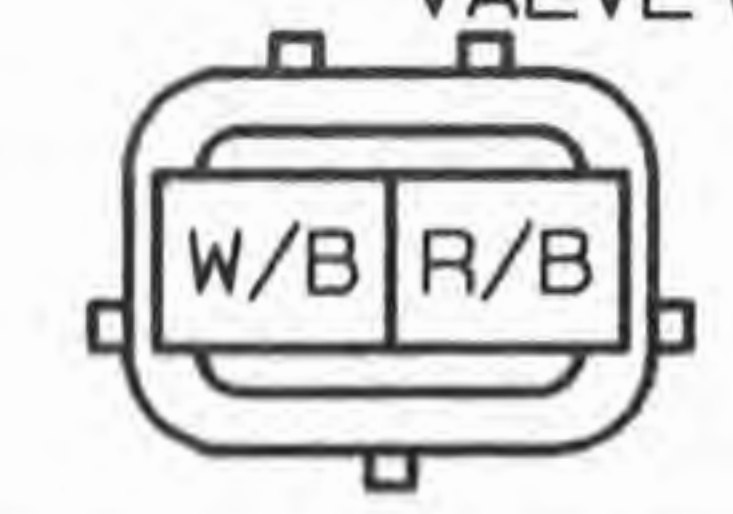

B1-23 PRC SOLENOID VALVE (E)

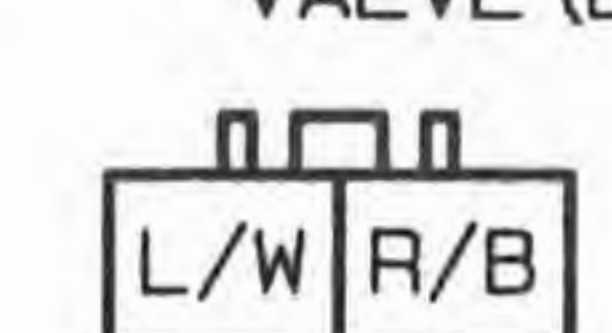

B1-24 IDLE AIR CONTROL VALVE (E)



B1-25 EGR SOLENOID VALVE (VACUUM) (E)



B1-26 EGR SOLENOID VALVE (VENT) (E)

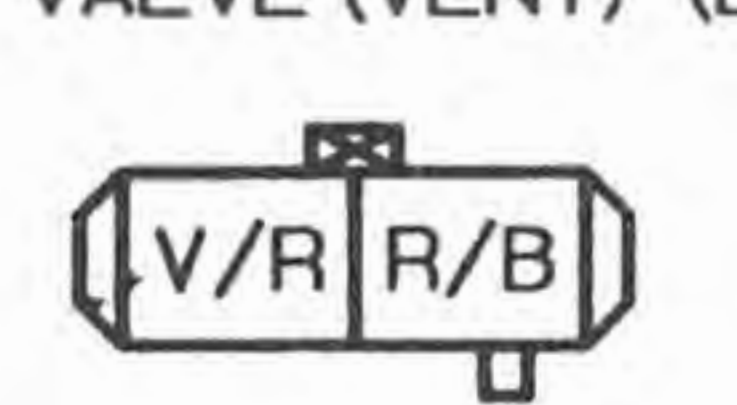

B1-28 MASS AIR FLOW SENSOR (EM)

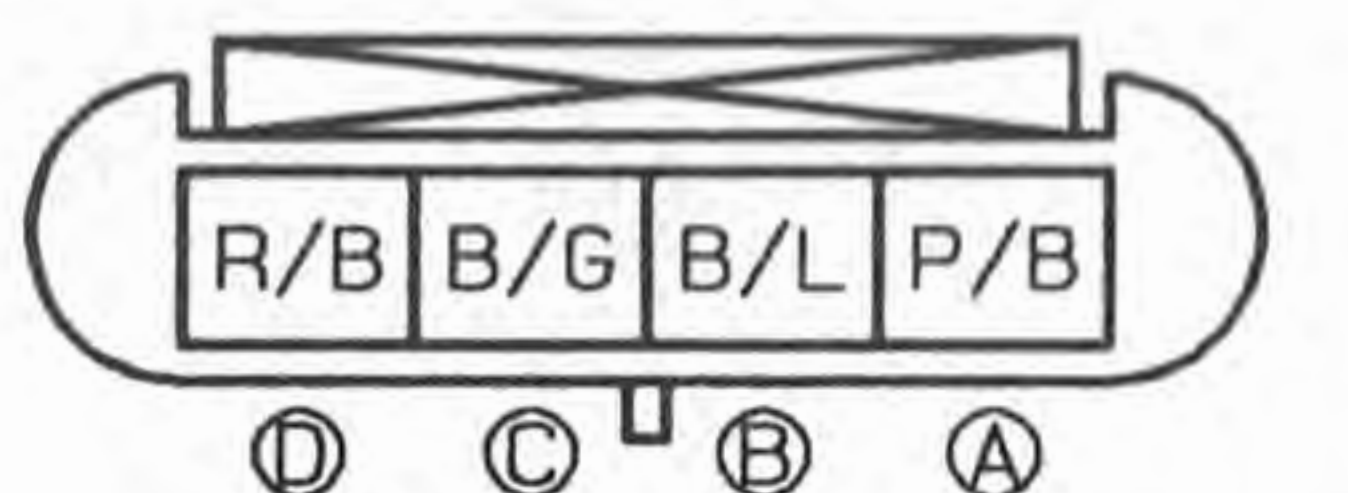

B1-27 SOLENOID BODY (EM)

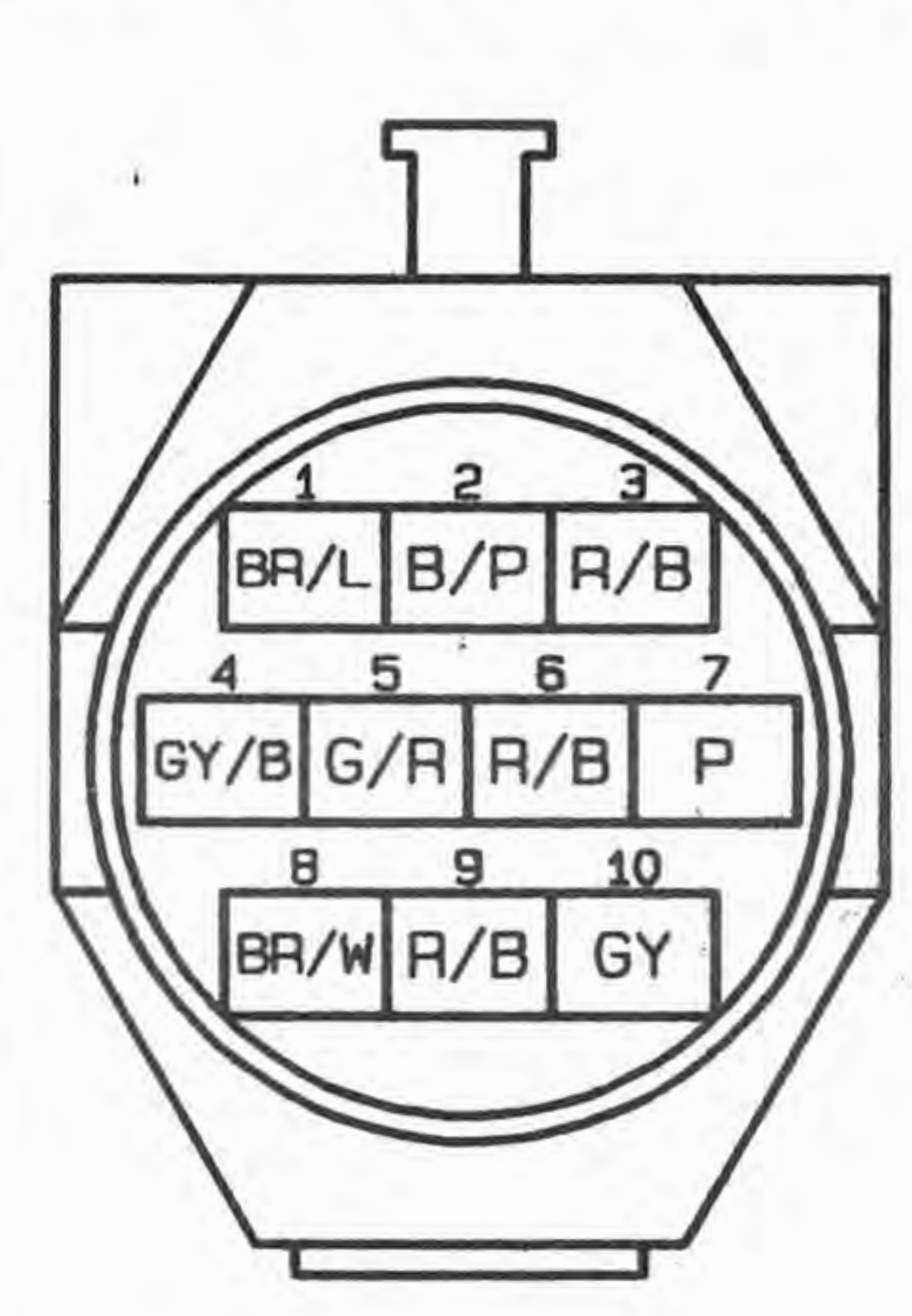

B-1d

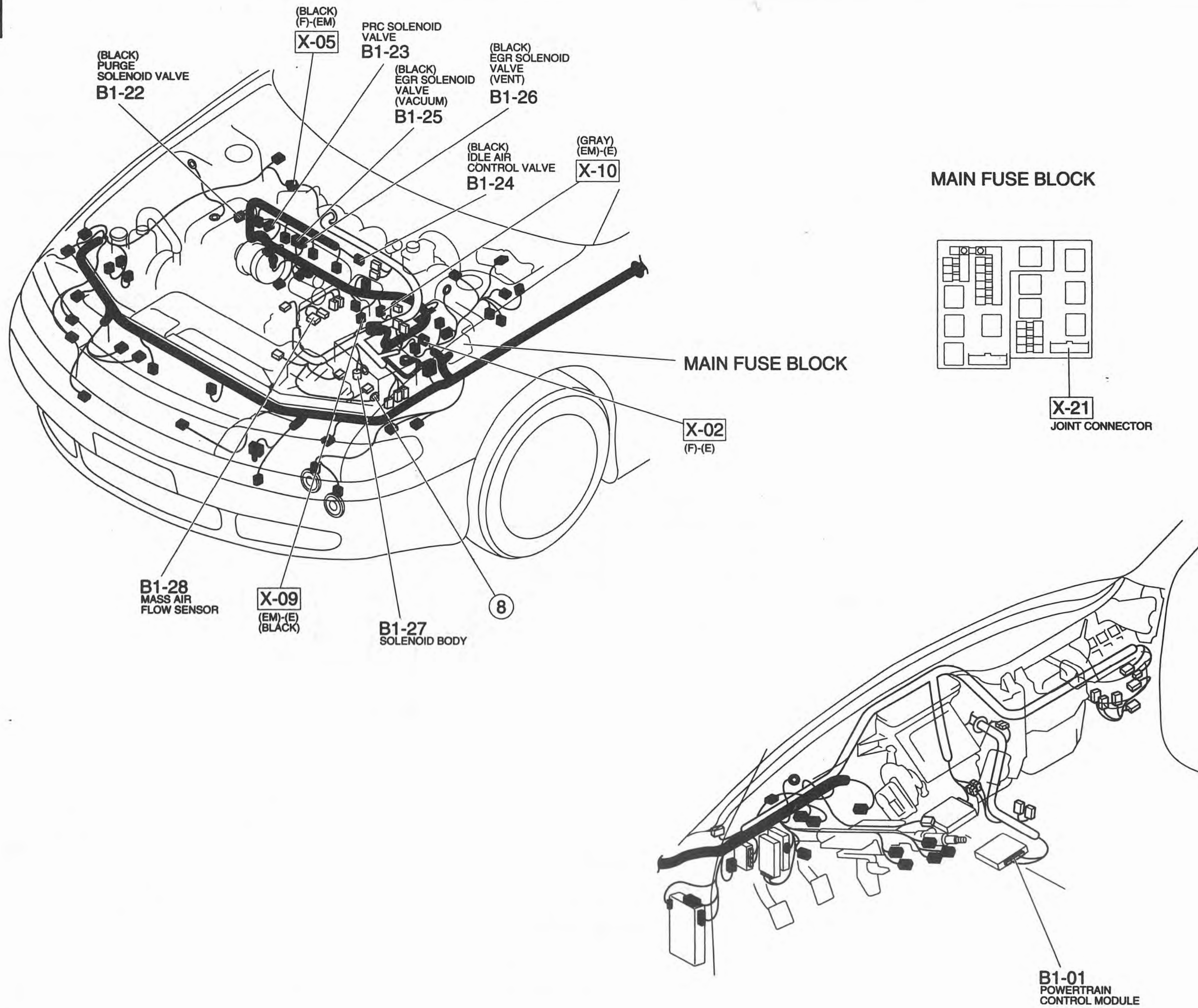

Z WIRING DIAGRAM

B-2a

FS MTX

- ENGINE CONTROL SYSTEM
- IGNITION SYSTEM

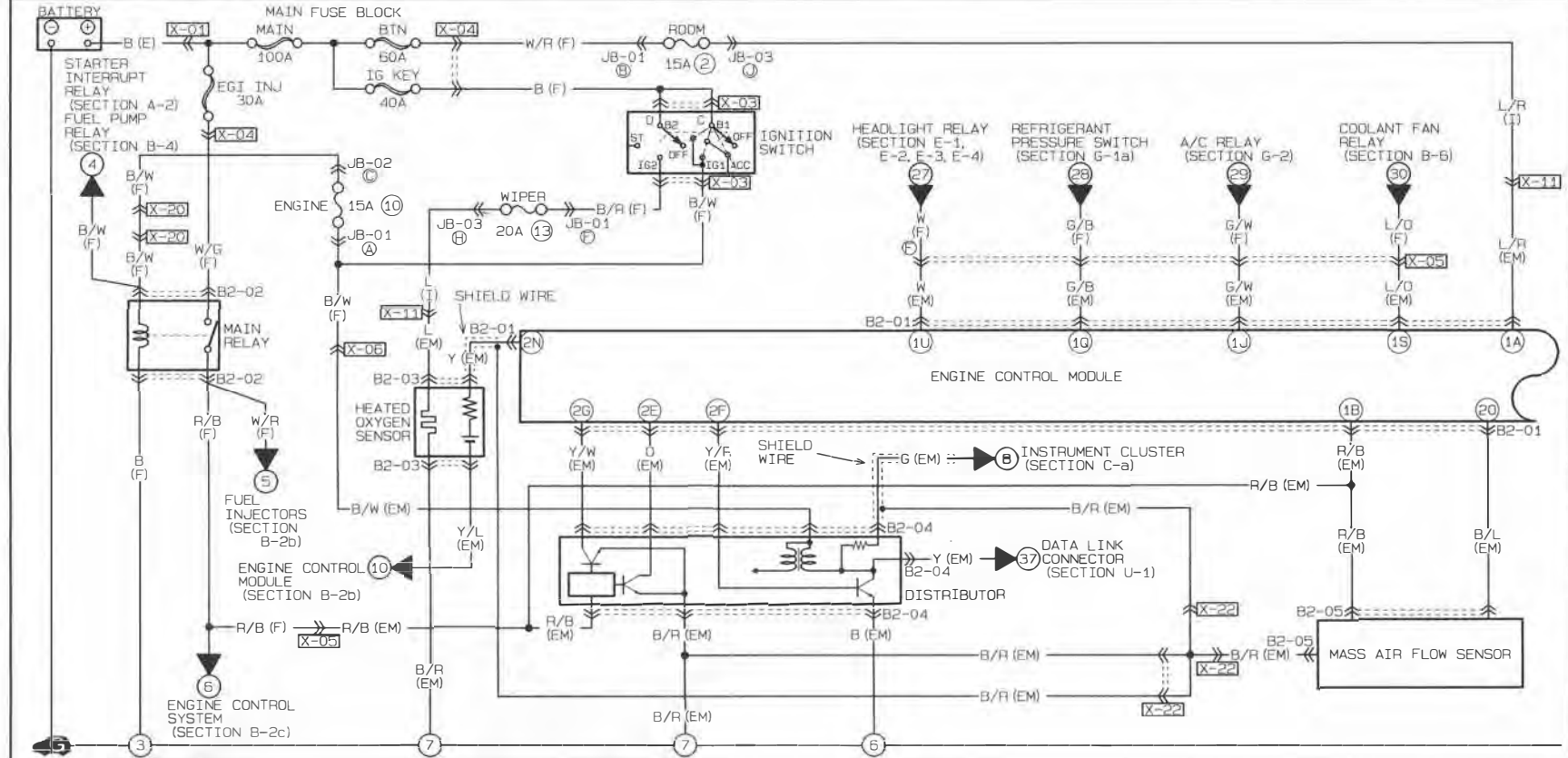

B2-01 ENGINE CONTROL MODULE (EM)

1U	1S	1Q	1O	1M	1K	1J	1G	1E	1C	1A	2Y	2W	2U	2S	2Q	2O	2M	2K	2I	2G	2E	2C	2A
W	L/O	G/B	W/G	G/R	R/W	G	*	L	B/L	L/R	L/R	GY/R	R/W	W/L	R/B	B/L	P/G	G/L	*	Y/W	O	B/R	B
G/Y	*	L/B	L/Y	BR	V	G/W	LG	LG/R	W	R/B	R/Y	W/B	L/W	L/W	V/R	*	Y	L/R	R	*	Y/R	Y/L	B
1V	1T	1R	1P	1N	1L	1J	1H	1F	1D	1B	2Z	2X	2V	2T	2R	2P	2N	2L	2J	2H	2F	2D	2B

B2-02 MAIN RELAY (F)

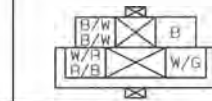

B2-03 HEATED OXYGEN SENSOR (EM)



B2-04 DISTRIBUTOR (EM)



B2-05 MASS AIR FLOW SENSOR (EM)

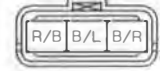

B-2a

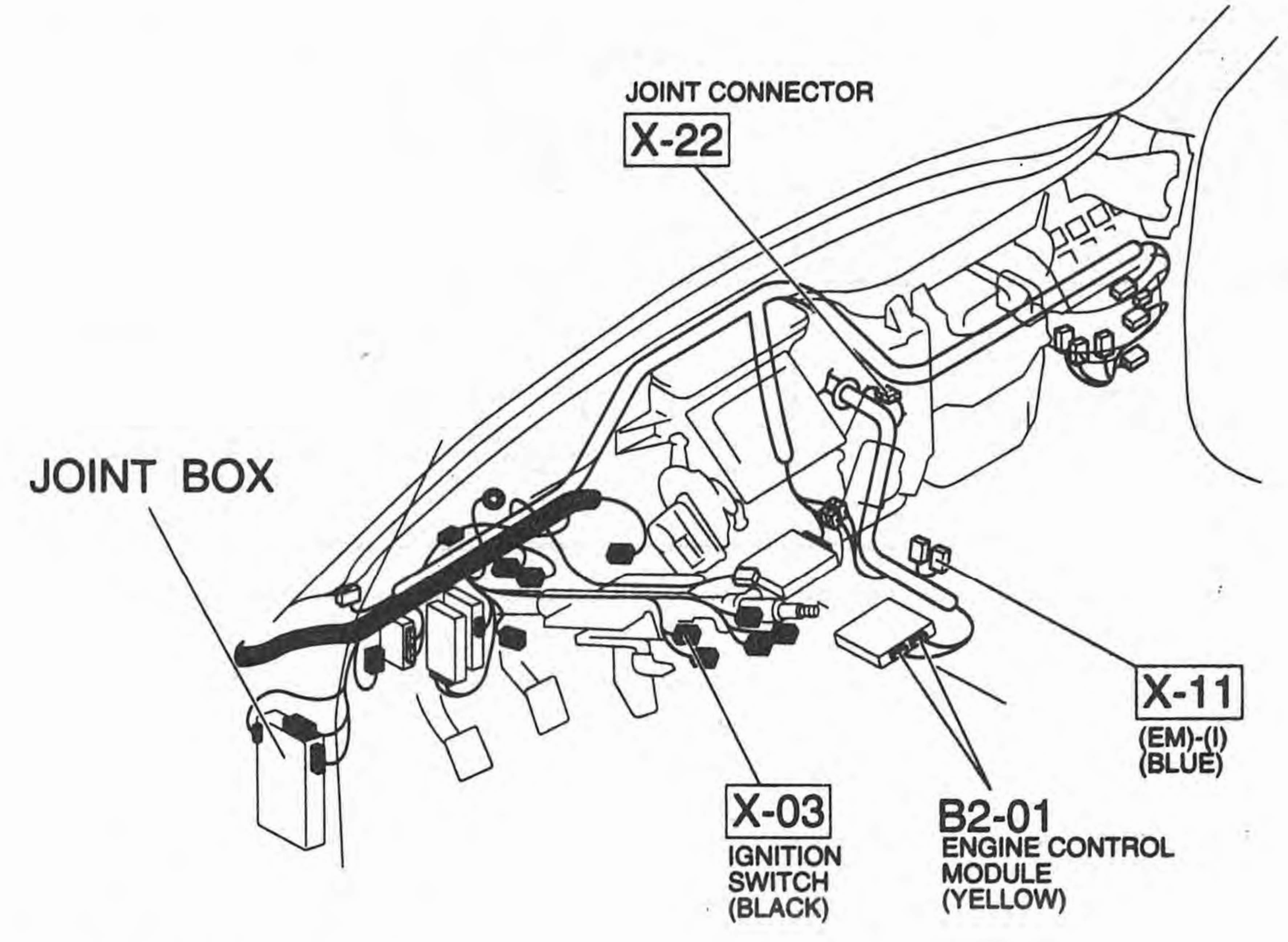
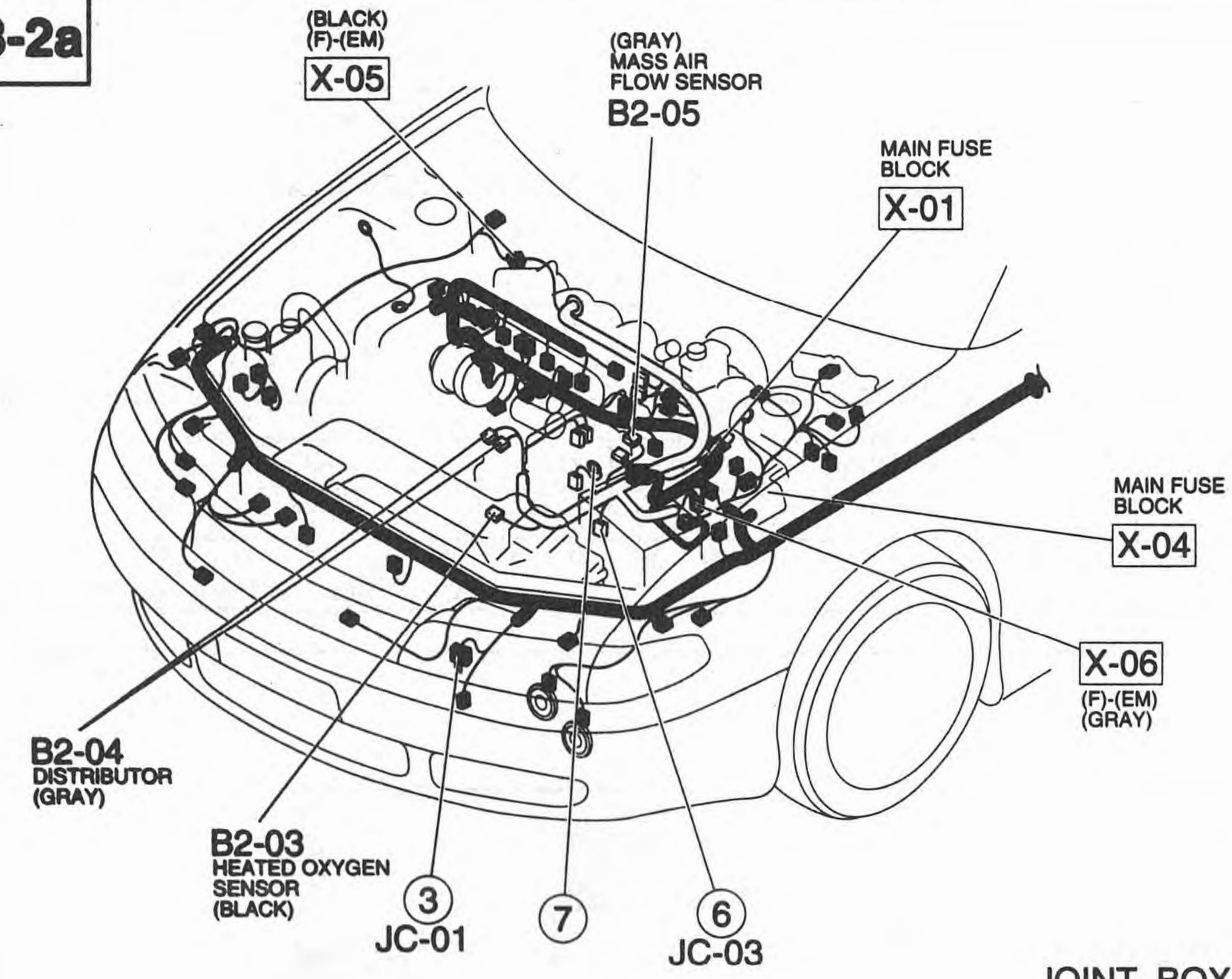

JOINT BOX

MAIN FUSE BOX

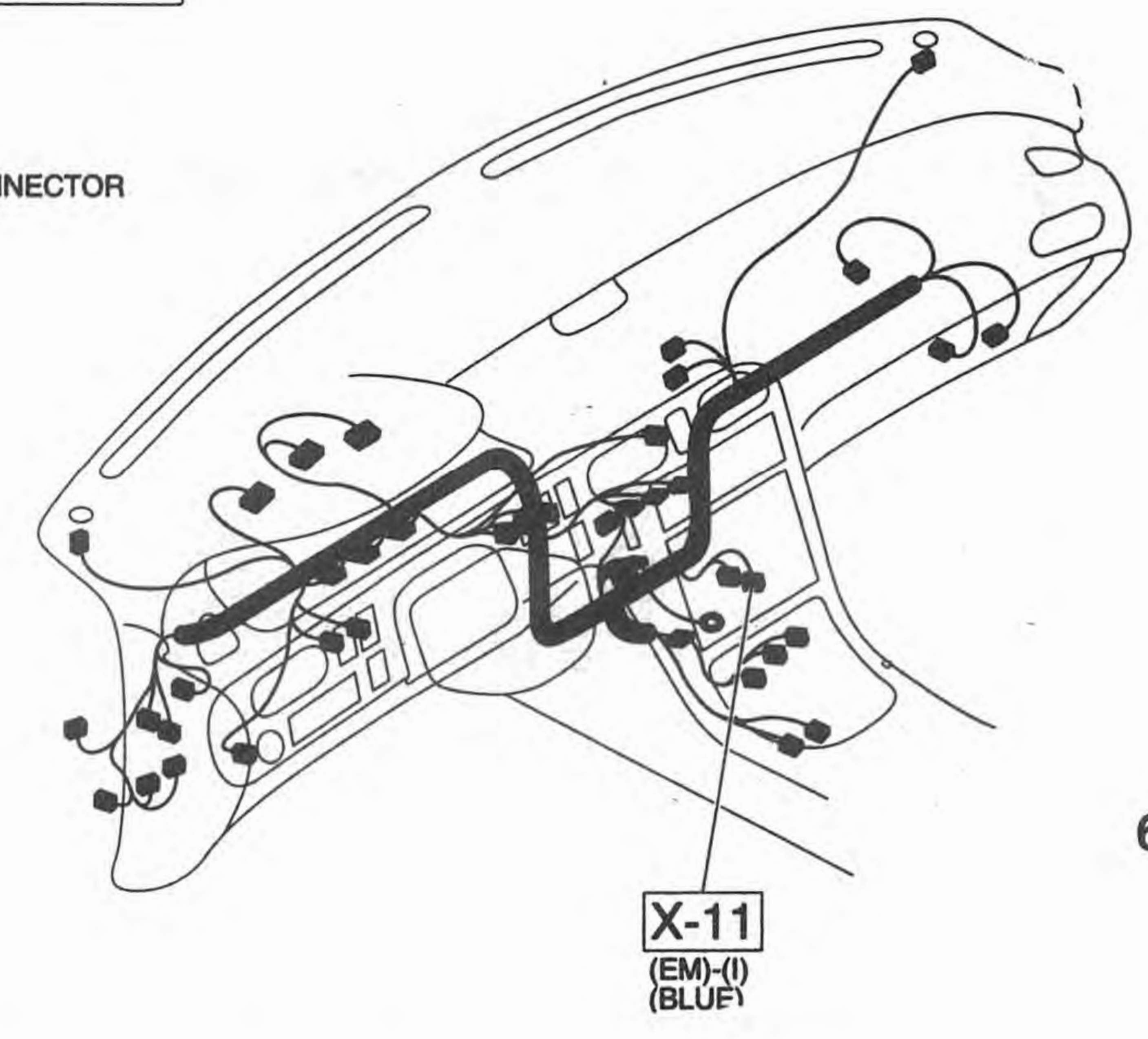
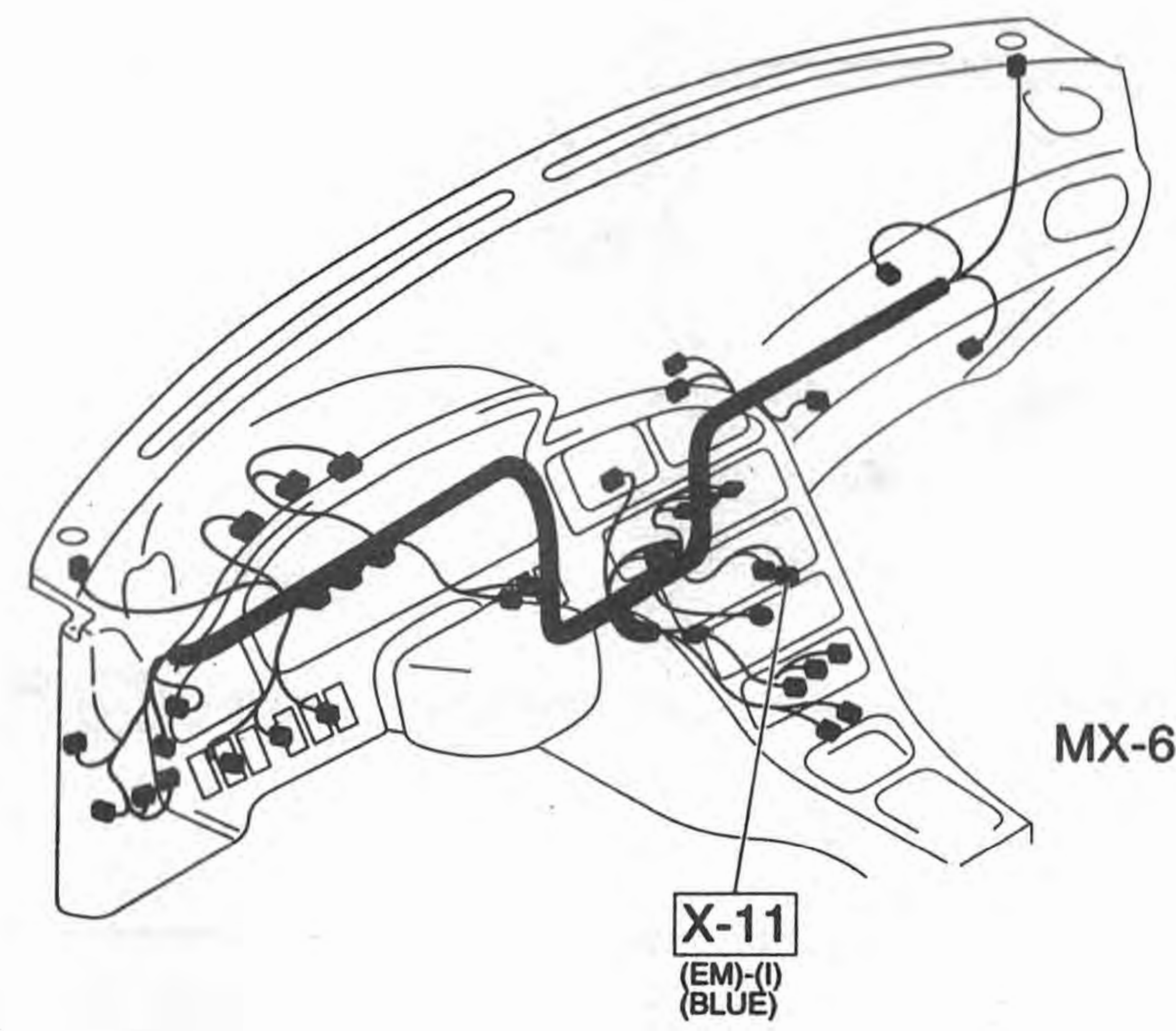
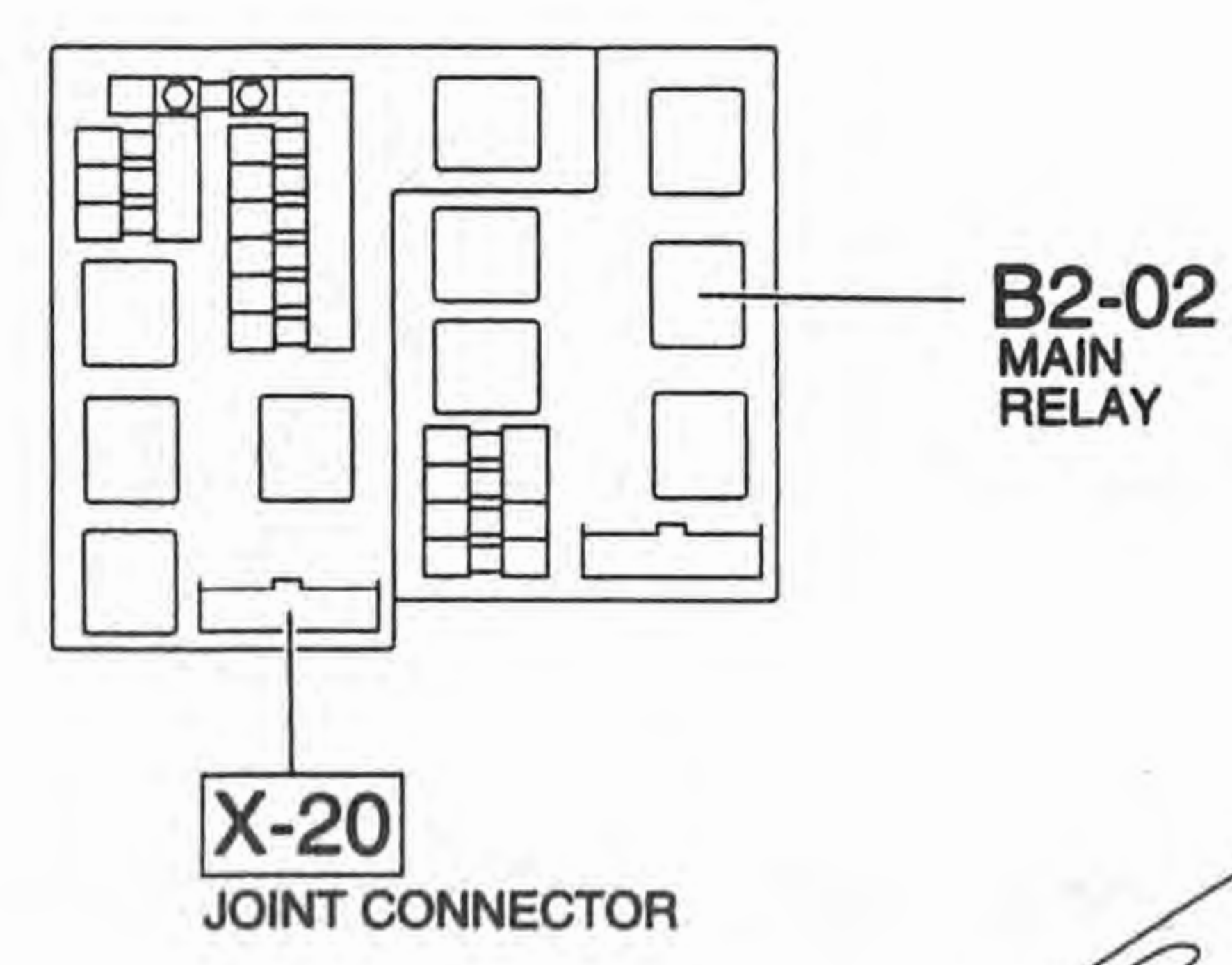
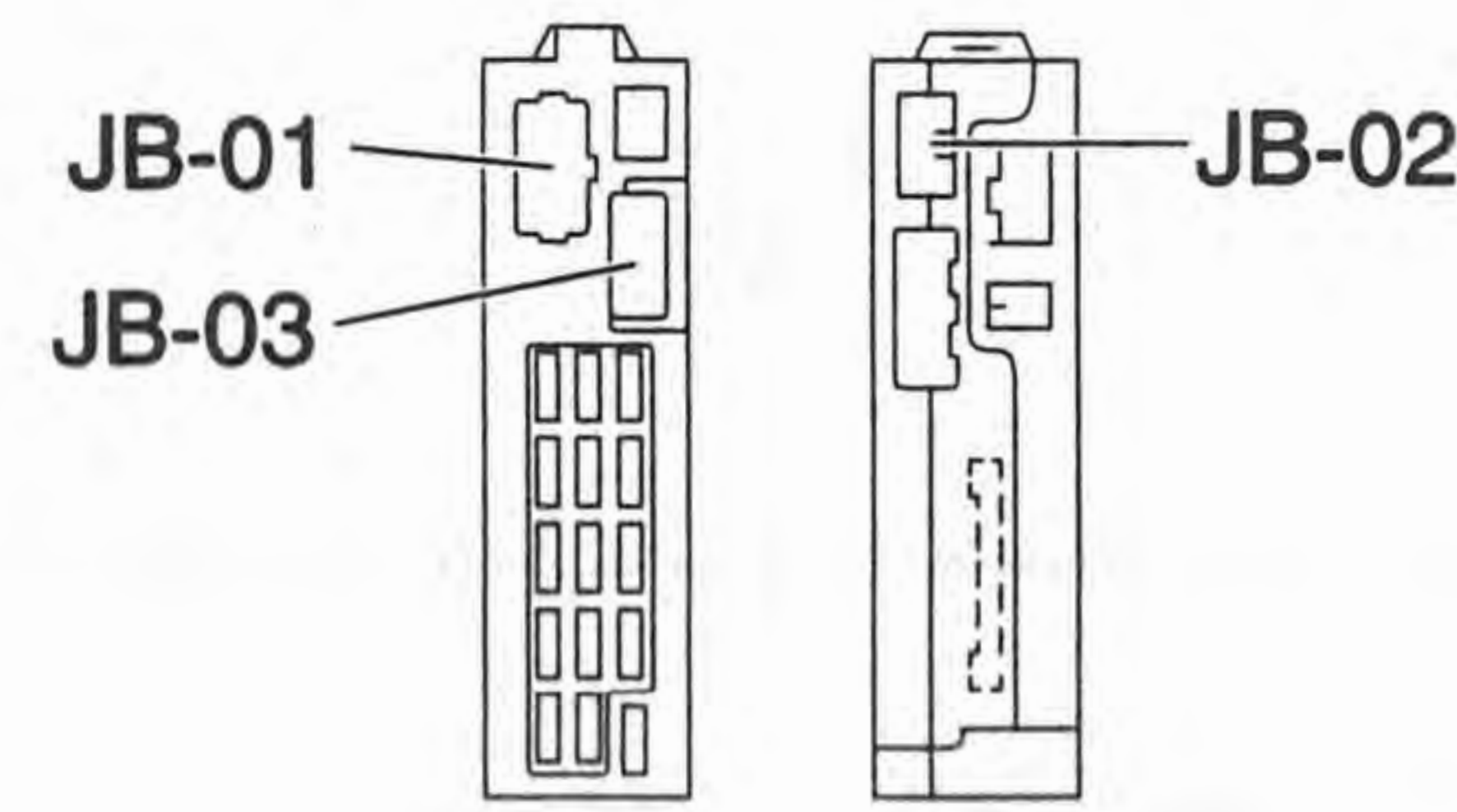

626

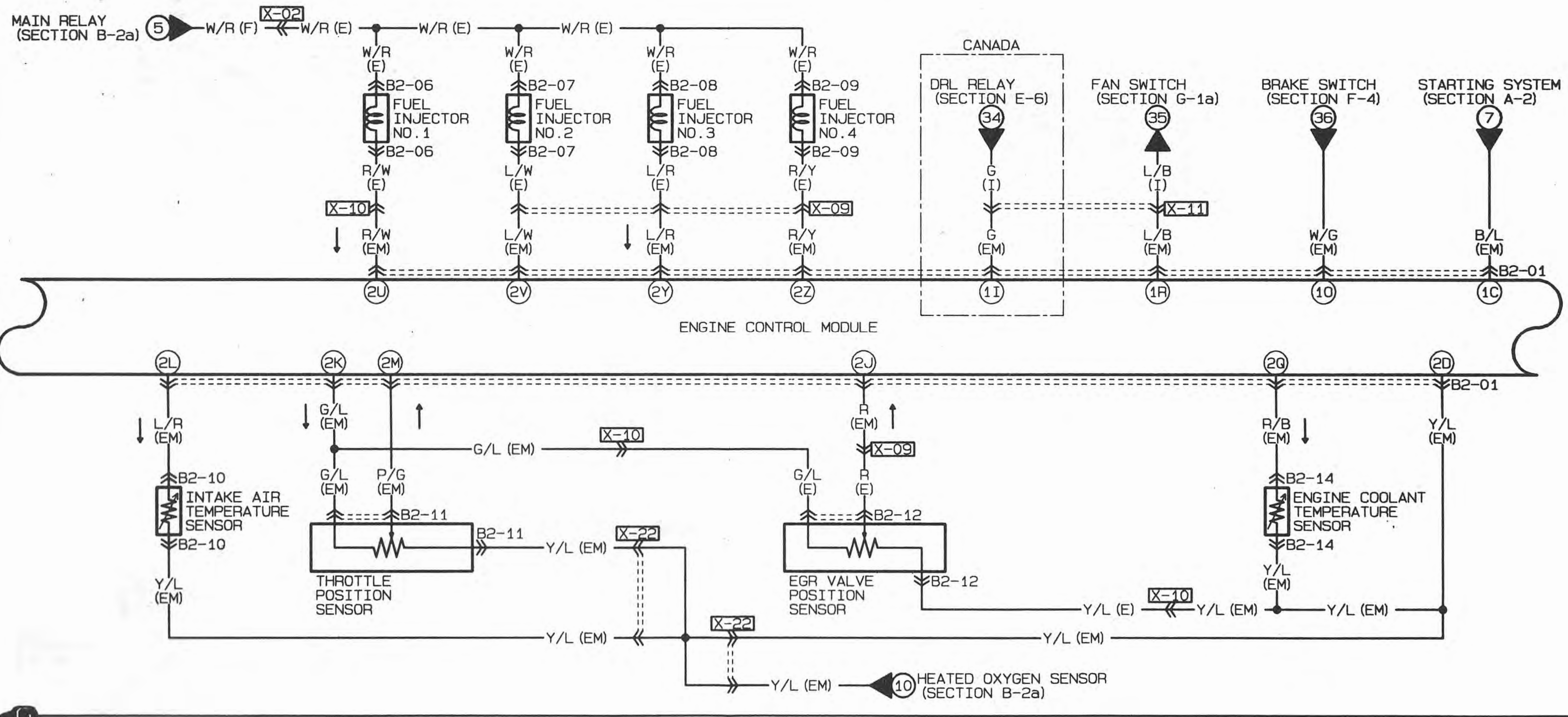

B2-01 ENGINE CONTROL MODULE (EM)

1U	1S	1Q	1O	1M	1K	1I	1G	1E	1C	1A
W	L/D	G/B	W/G	G/R	R/W	G	*	L	B/L	L/R
G/Y	*	L/B	L/Y	BR	V	G/W	LG	LG/R	W	R/B
1V	1T	1R	1P	1N	1L	1J	1H	1F	1D	1B

2Y	2W	2U	2S	2Q	2O	2M	2K	2I	2G	2E	2C	2A
L/R	G/Y	R/W	W/L	R/B	B/L	P/G	G/L	*	Y/W	O	B/R	B
R/Y	W/B	L/W	L/W	V/R	*	Y	L/R	R	*	Y/R	Y/L	B
2Z	2X	2V	2T	2R	2P	2N	2L	2J	2H	2F	2D	2B

B2-06 FUEL INJECTOR NO. 1 (E)



B2-07 FUEL INJECTOR NO. 2 (E)



B2-08 FUEL INJECTOR NO. 3 (E)



B2-09 FUEL INJECTOR NO. 4 (E)



B2-10 INTAKE AIR TEMPERATURE SENSOR (EM)



B2-11 THROTTLE POSITION SENSOR (EM)

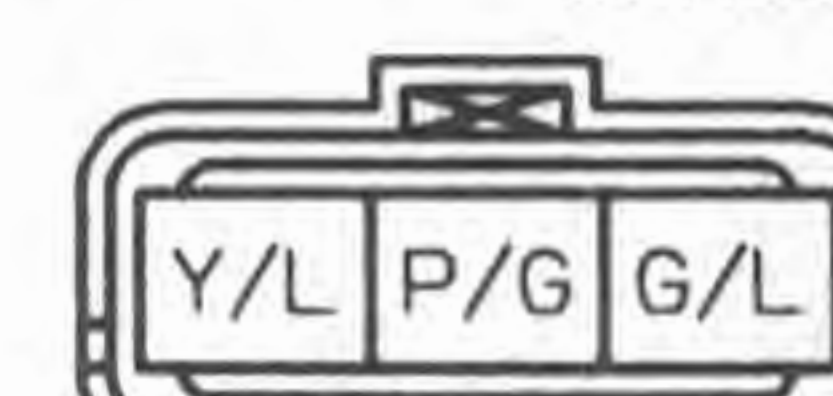

B2-12 EGR VALVE POSITION SENSOR (E)



B2-14 ENGINE COOLANT TEMPERATURE SENSOR (EM)



B-2b

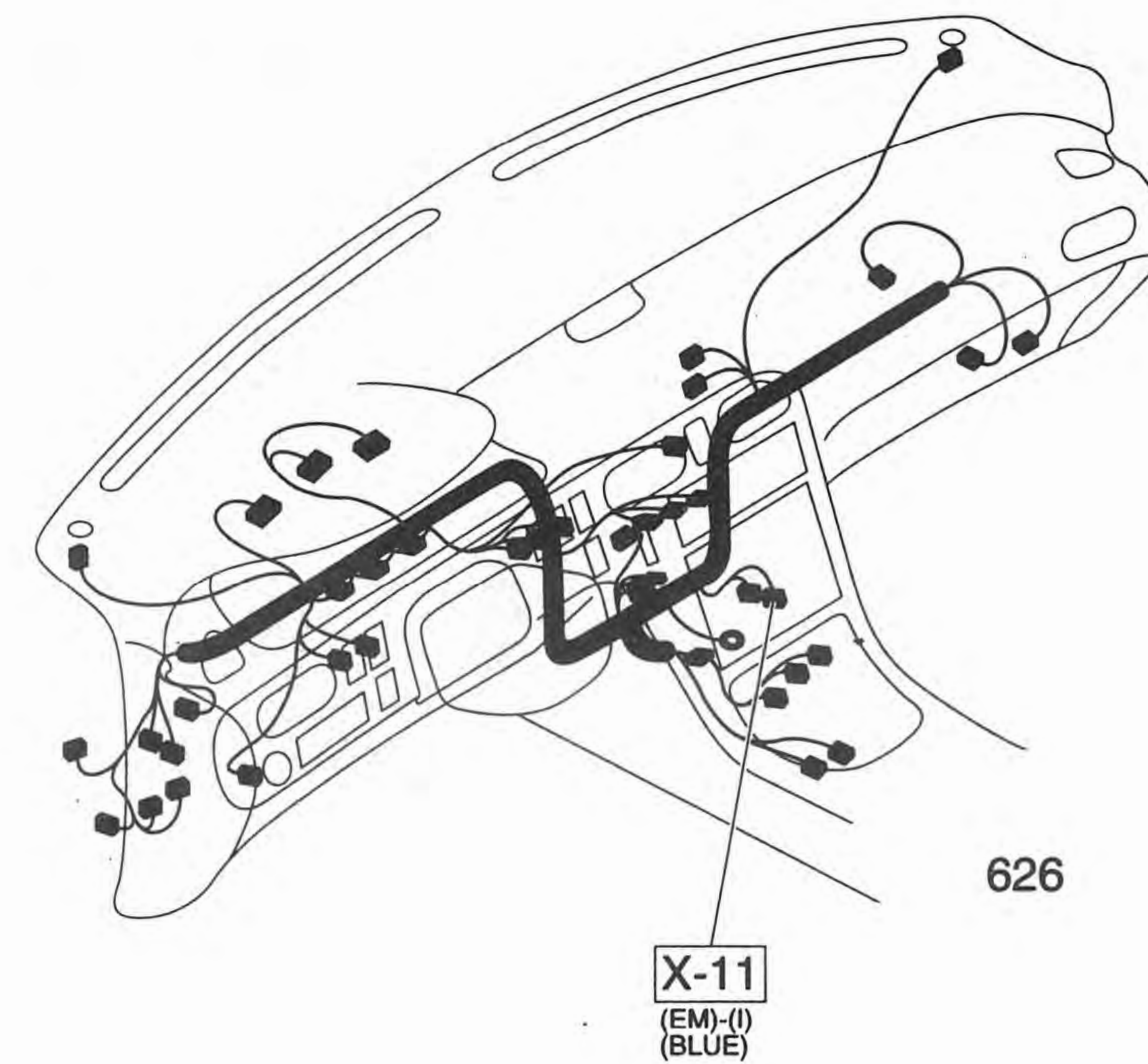
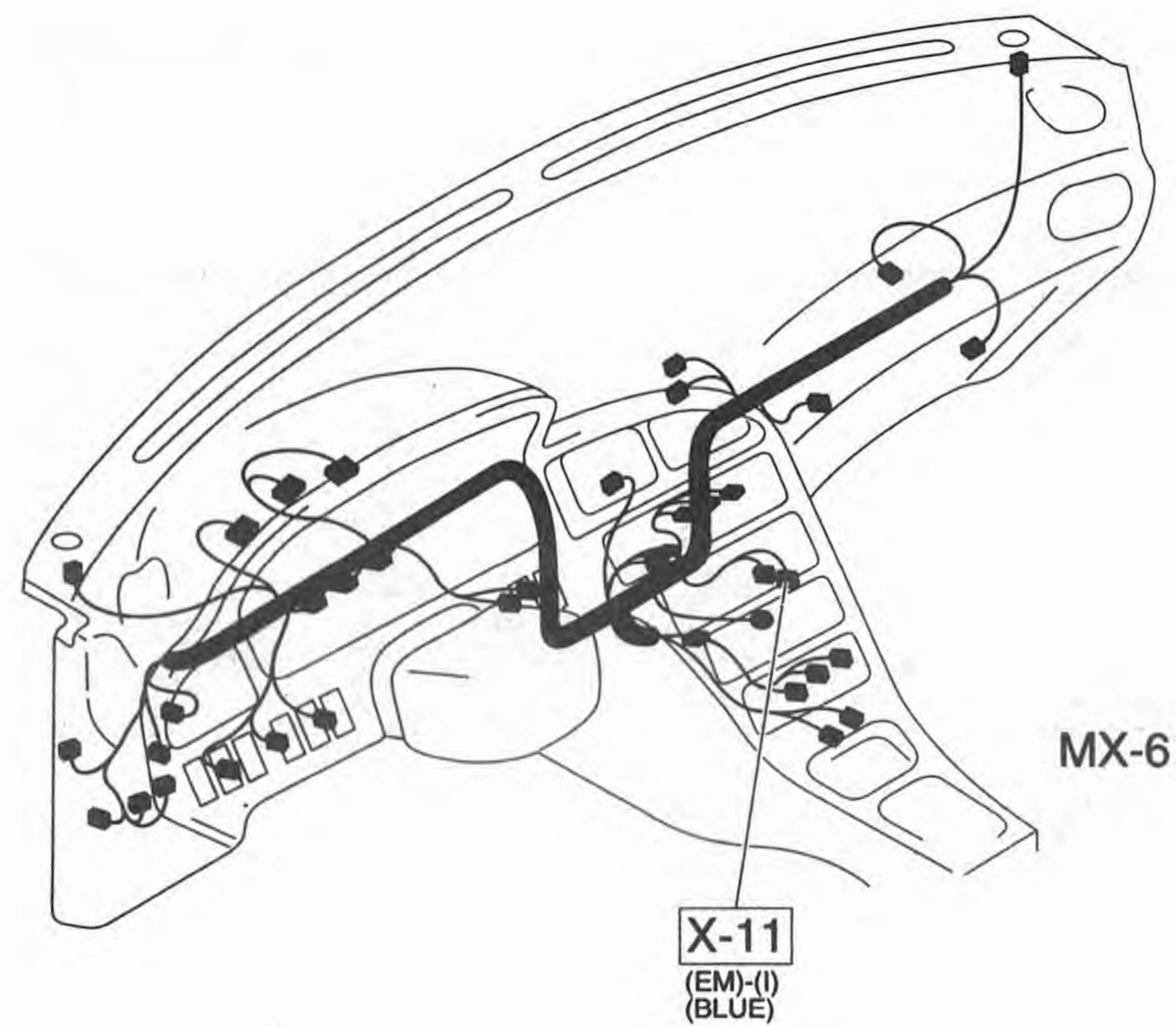
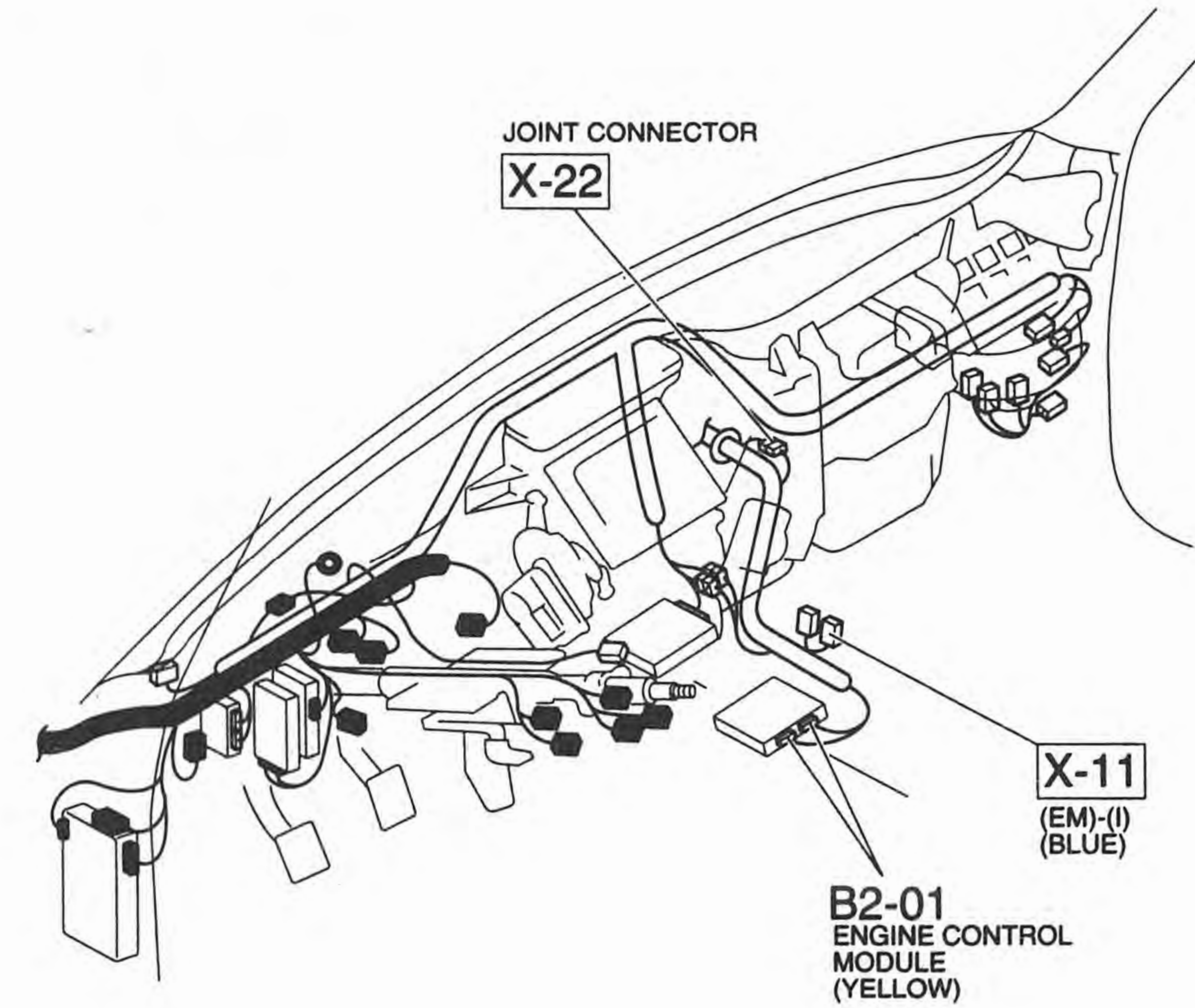
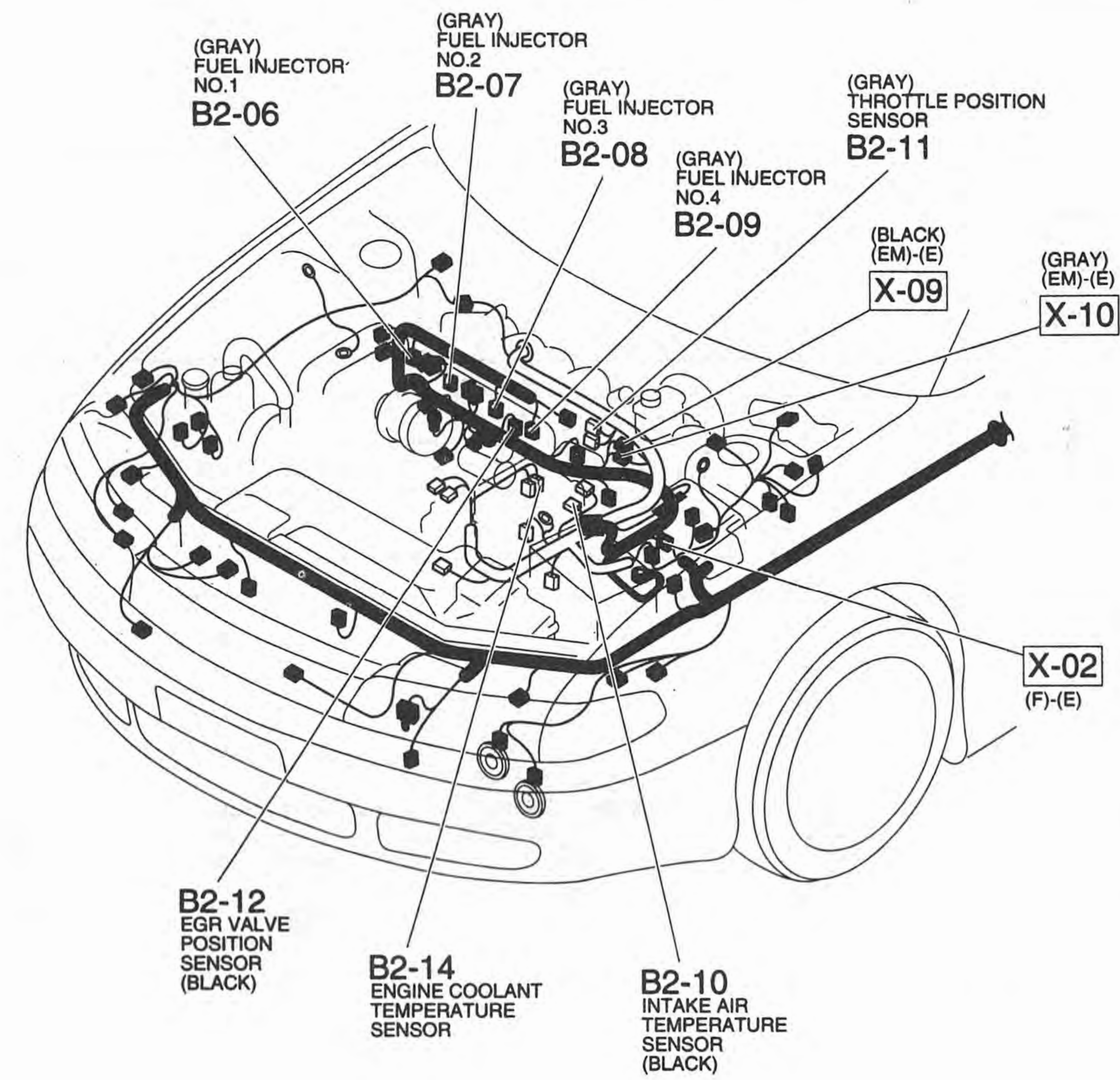

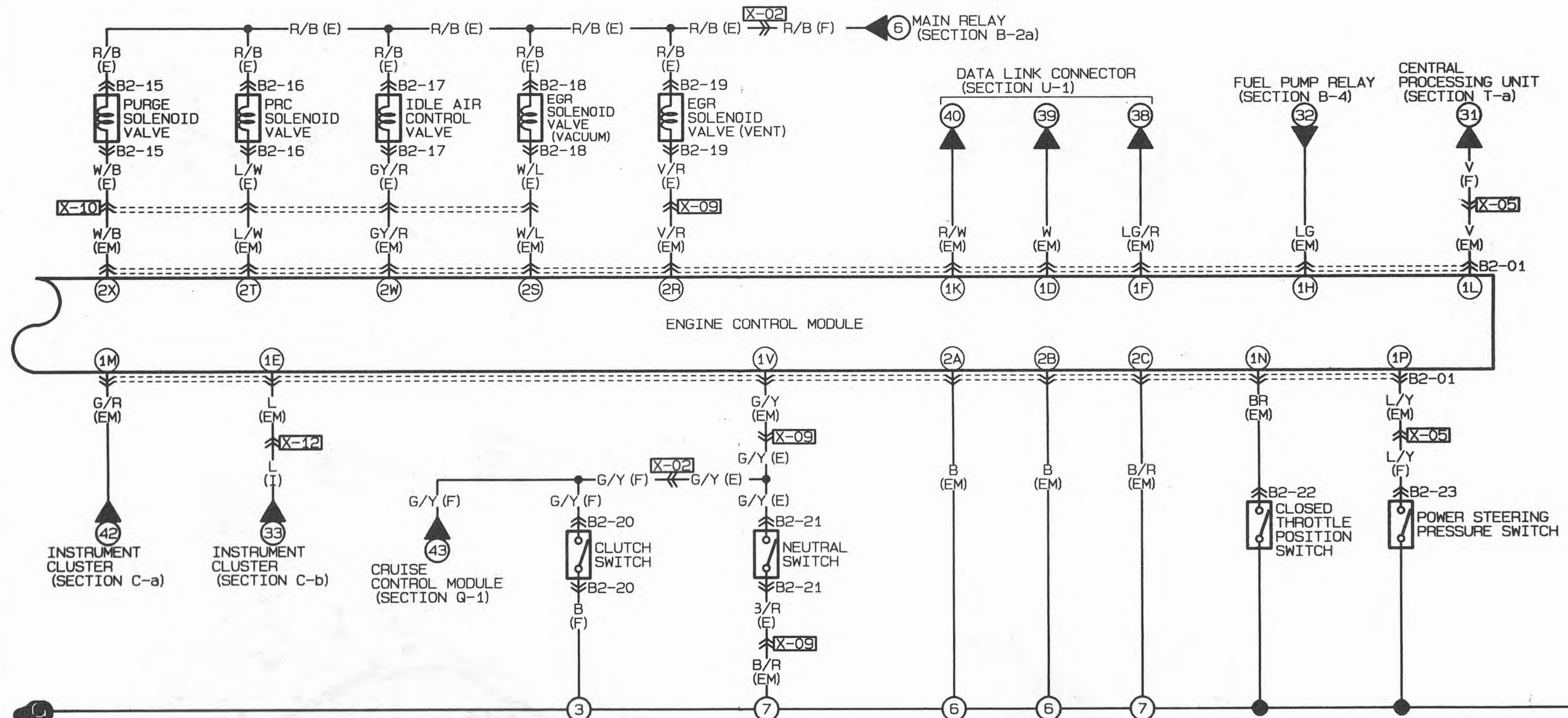

B2-01 ENGINE CONTROL MODULE (EM)

1U	1S	1Q	1O	1M	1K	1I	1G	1E	1C	1A	2Y	2W	2U	2S	2Q	2O	2M	2K	2I	2G	2E	2C	2A
W	L/D	G/B	W/G	G/R	R/W	G	*	L	B/L	L/R	L/R	GY/R	R/W	W/L	R/B	B/L	P/G	G/L	*	Y/W	O	B/R	B
G/Y	*	L/B	L/Y	BR	V	G/W	LG	LG/R	W	R/B	R/Y	W/B	L/W	L/W	V/R	*	Y	L/R	R	*	Y/R	Y/L	B
1V	1T	1R	1P	1N	1L	1J	1H	1F	1D	1B	2Z	2X	2V	2T	2R	2P	2N	2L	2J	2H	2F	2D	2B

B2-15 PURGE SOLENOID VALVE (E)

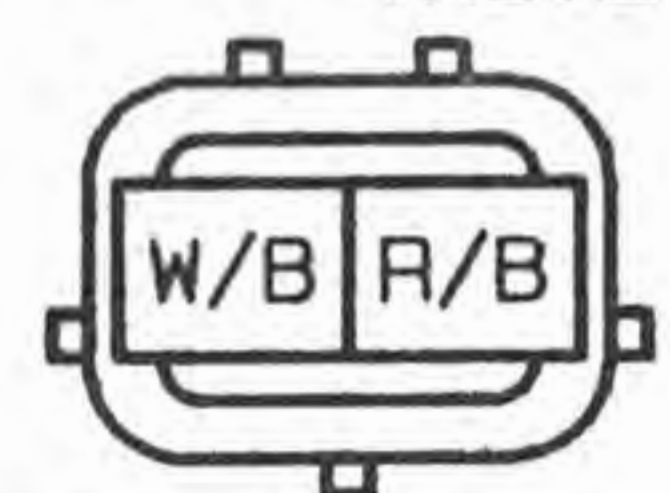

B2-16 PRC SOLENOID VALVE (E)



B2-17 IDLE AIR CONTROL VALVE (E)



B2-18 EGR SOLENOID VALVE (VACUUM) (E)



B2-19 EGR SOLENOID VALVE (VENT) (E)



B2-20 CLUTCH SWITCH (F)

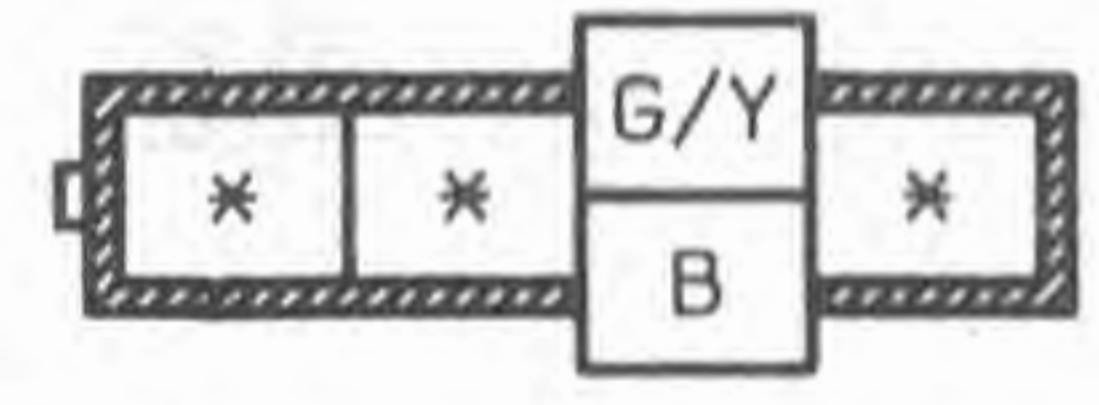

B2-21 NEUTRAL SWITCH (E)



B2-22 CLOSED THROTTLE POSITION SWITCH (EM)



B2-23 POWER STEERING PRESSURE SWITCH (F)



B-2c

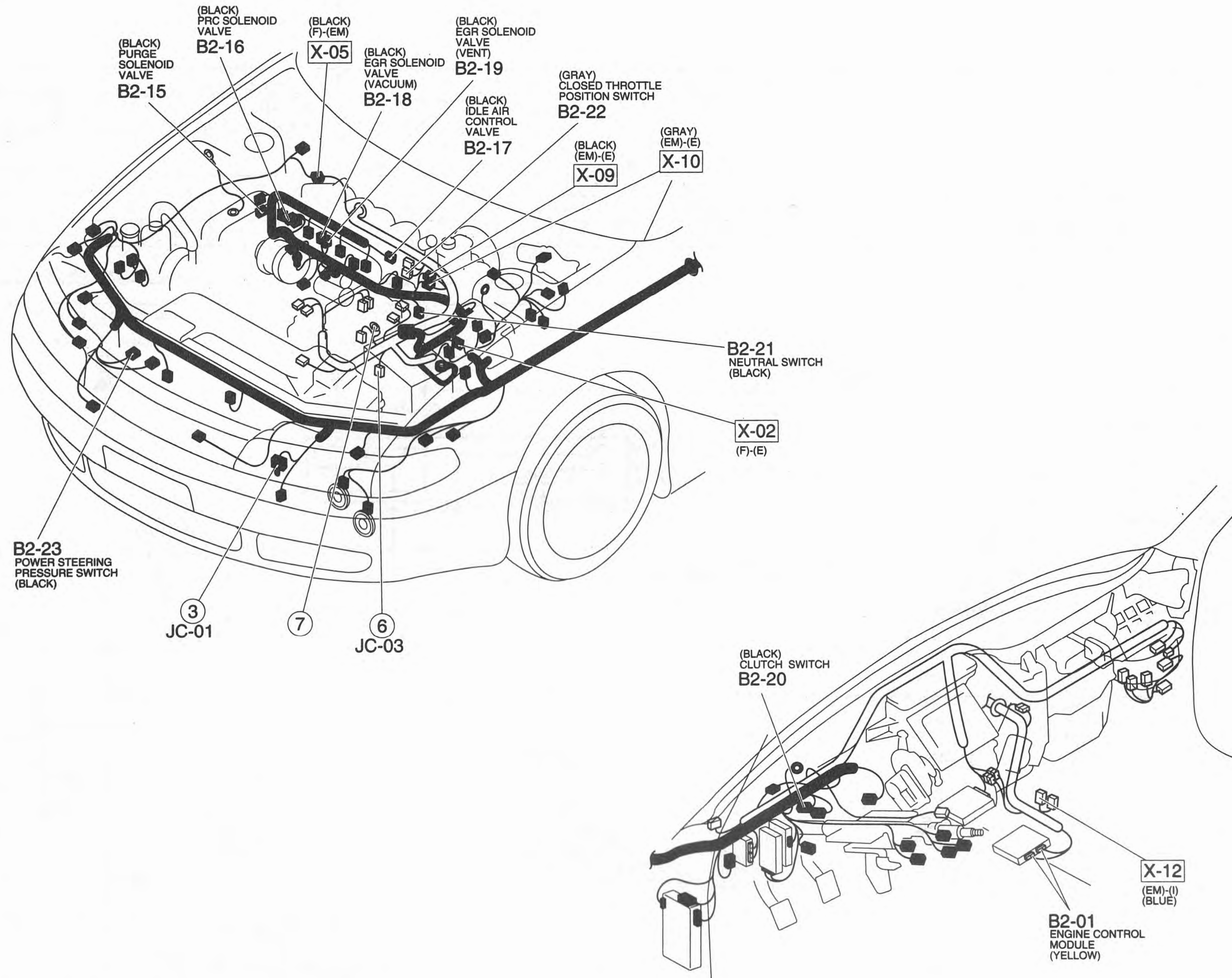

Z WIRING DIAGRAM

B-3a KL

**ENGINE CONTROL SYSTEM
IGNITION SYSTEM**

() ... ATX
▲ ... EXCEPT CANADA

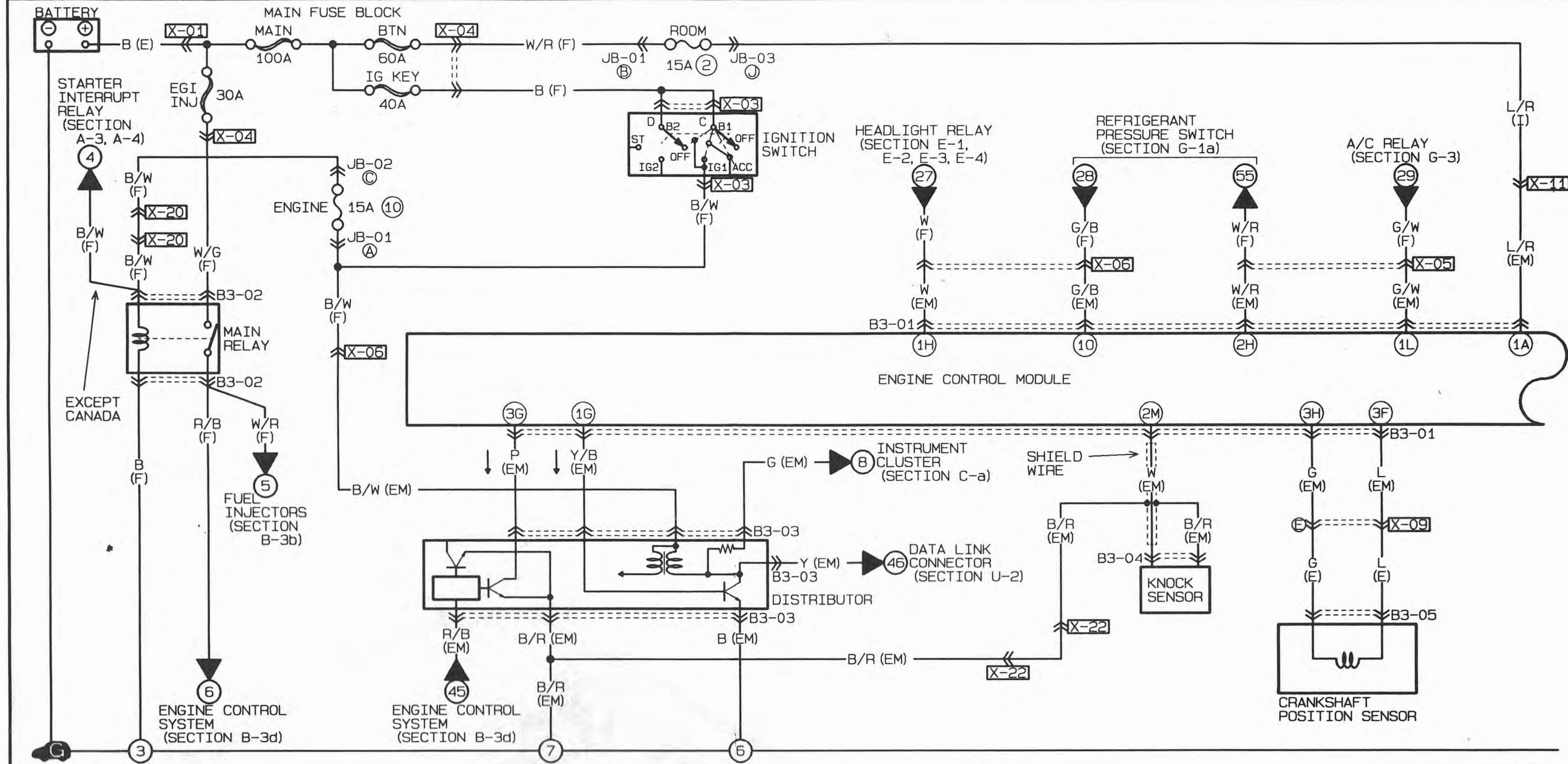

B3-01 ENGINE CONTROL MODULE (EM)

1U	1S	1Q	1O	1M	1K	1I	1G	1E	1C	1A
B/R (*)	*(BR/W)	W/G	G/B	G/R	*(Y/L)	R/W	Y/B	L	B/L	L/R
*(L)	BR	G/Y	L/B	L/Y	G/W	V	W	L	W	R/B
1V	1T	1R	1P	1N	1L	1J	1H	1F	1D	1B

20	2M	2K	2I	2G	2E	2C	2A
L/W	W	GY/B	G/L	*	R/G	Y	*(G/D)
W/B	*	B/Y (G)	R/B	W/R	P/G	G	R
2P	2N	2L	2J	2H	2F	2D	2B

3Y	3W	3U	3S	3Q	3O	3M	3K	3I	3G	3E	3C	3A
W	L/R	R/W	*	GY/R	P/B	GY/G	*	GY	P	LG (*)	B/R	B
W/G	R/Y	L/W	BR/B	*(L/G)	W/L	R	L/O	L/R	G	L	B/L	B
3Z	3X	3V	3T	3R	3P	3N	3L	3J	3H	3F	3D	3B

B3-02 MAIN RELAY (F)

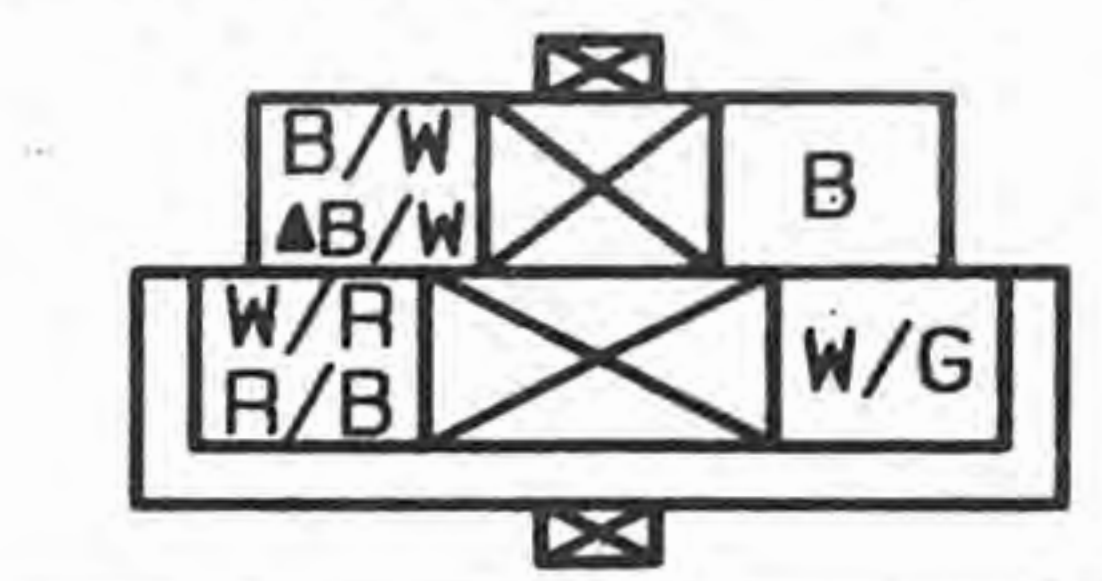

B3-03 DISTRIBUTOR (EM)

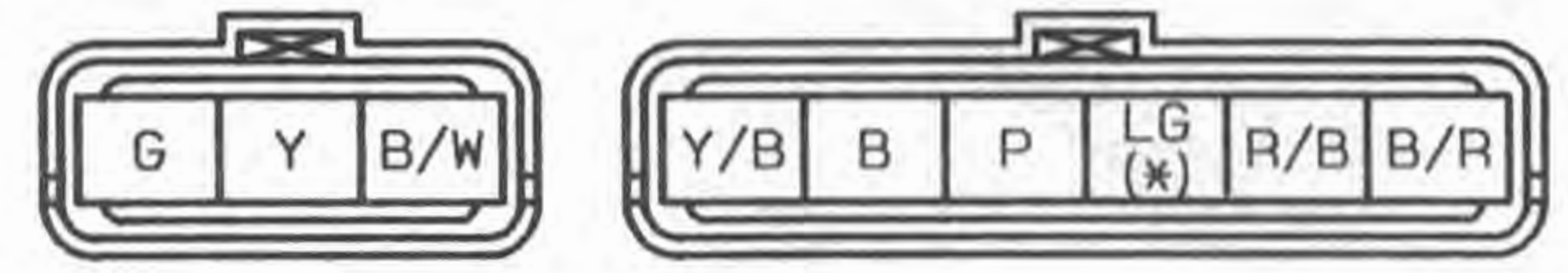

B3-04 KNOCK SENSOR (EM)



B3-05 CRANKSHAFT POSITION SENSOR (E)

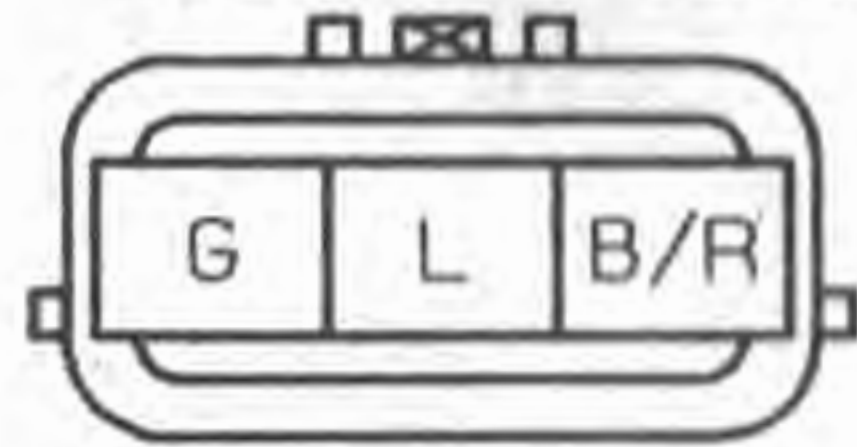

B-3a

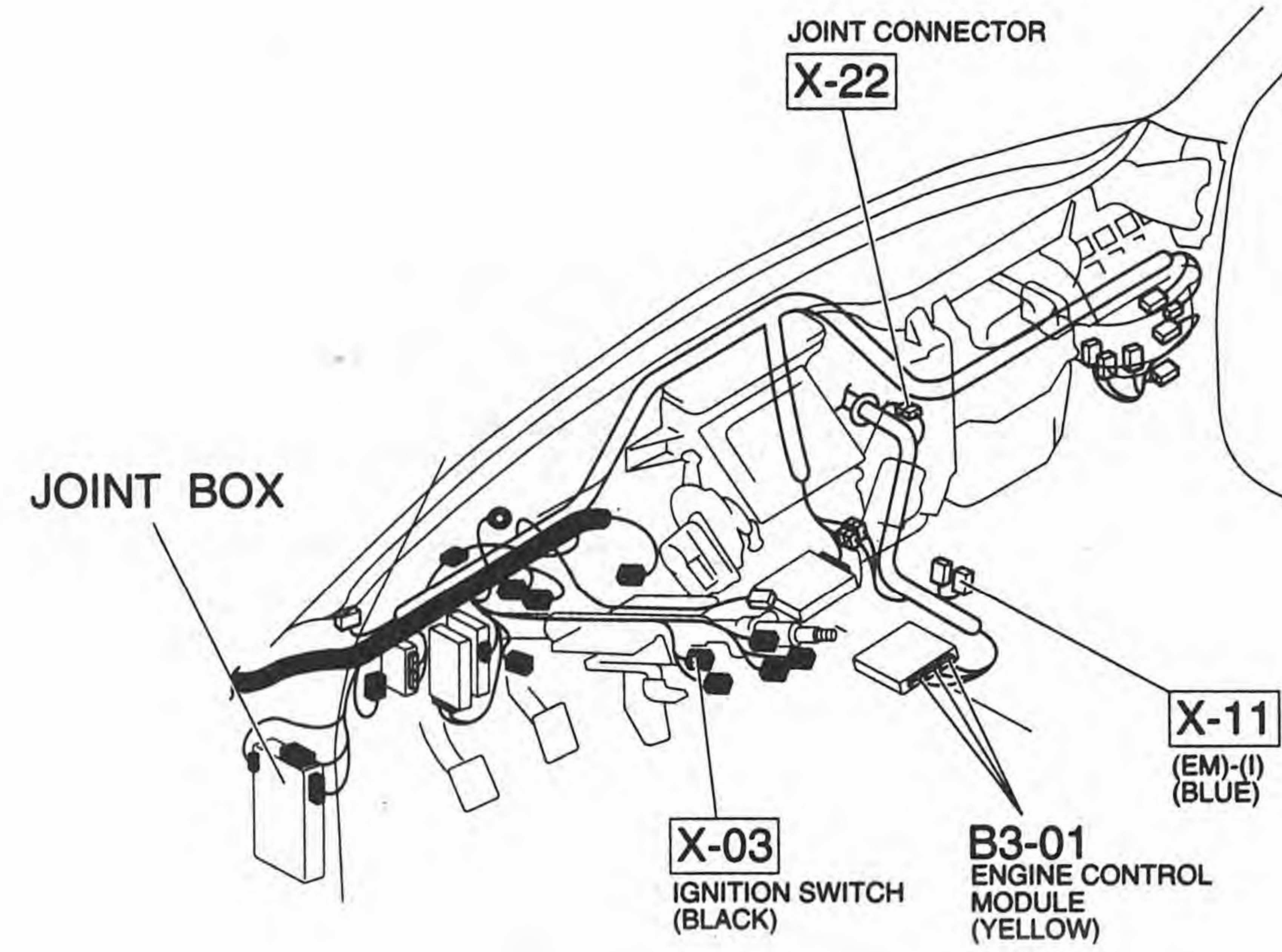
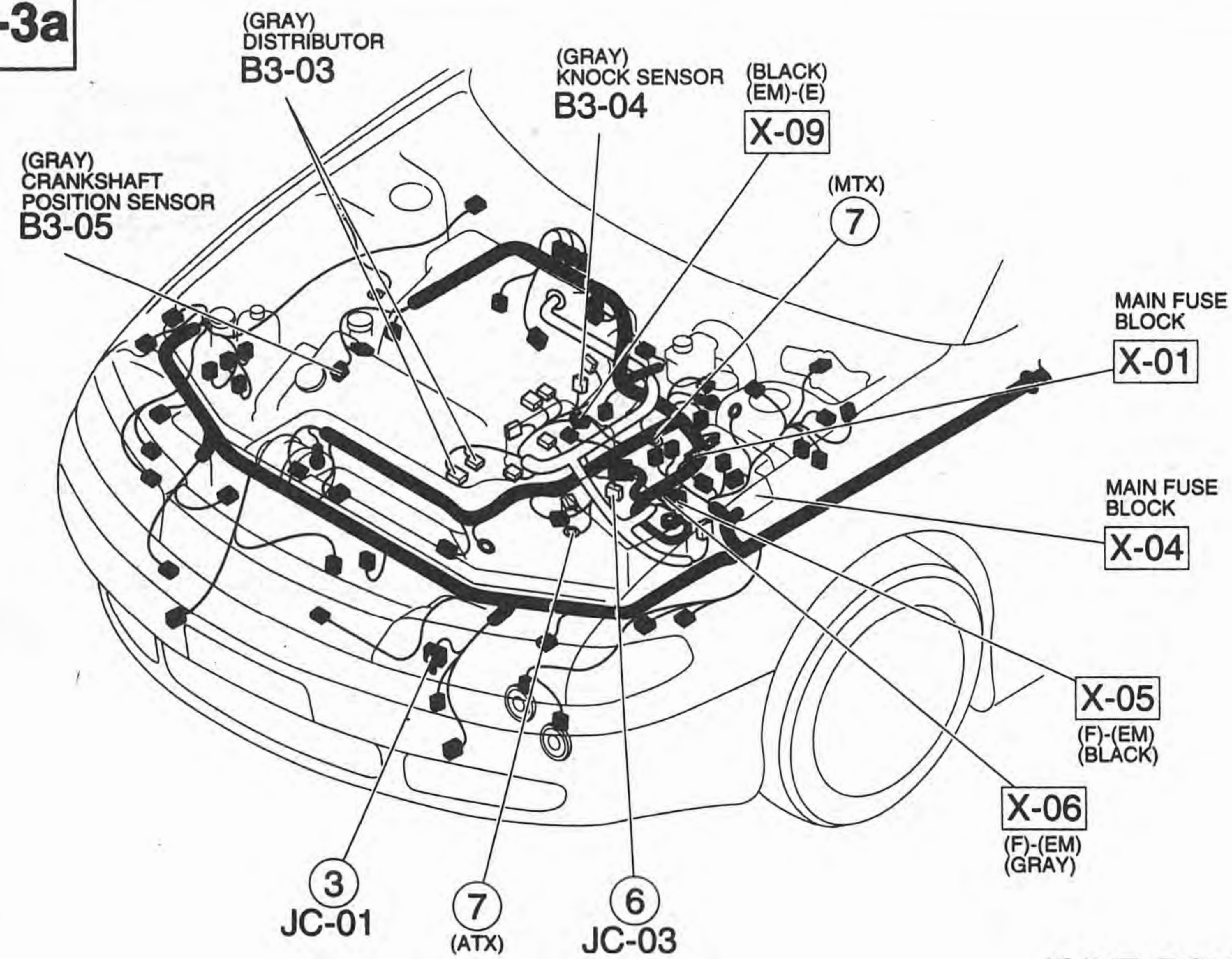

JOINT BOX

MAIN FUSE BOX

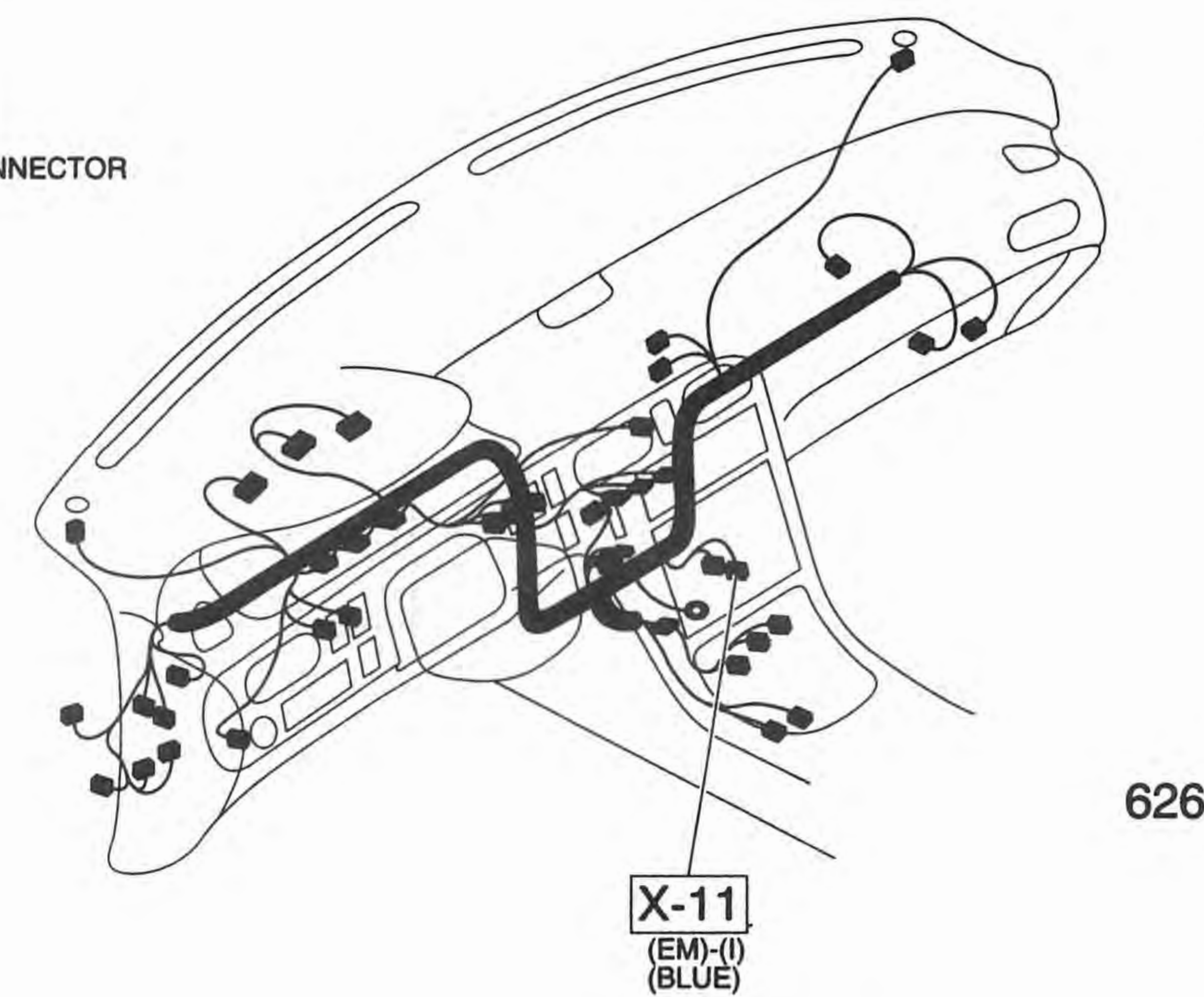
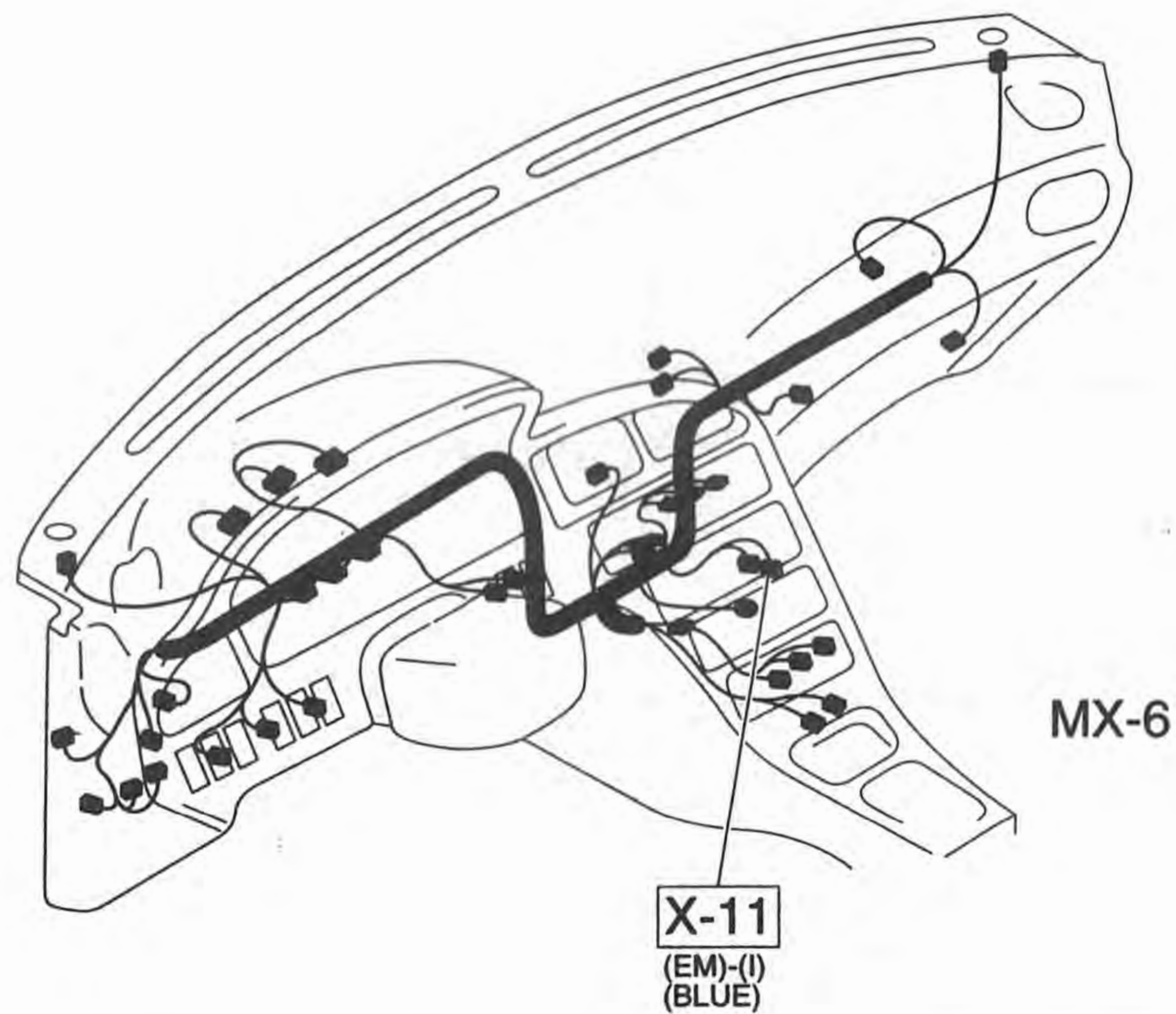
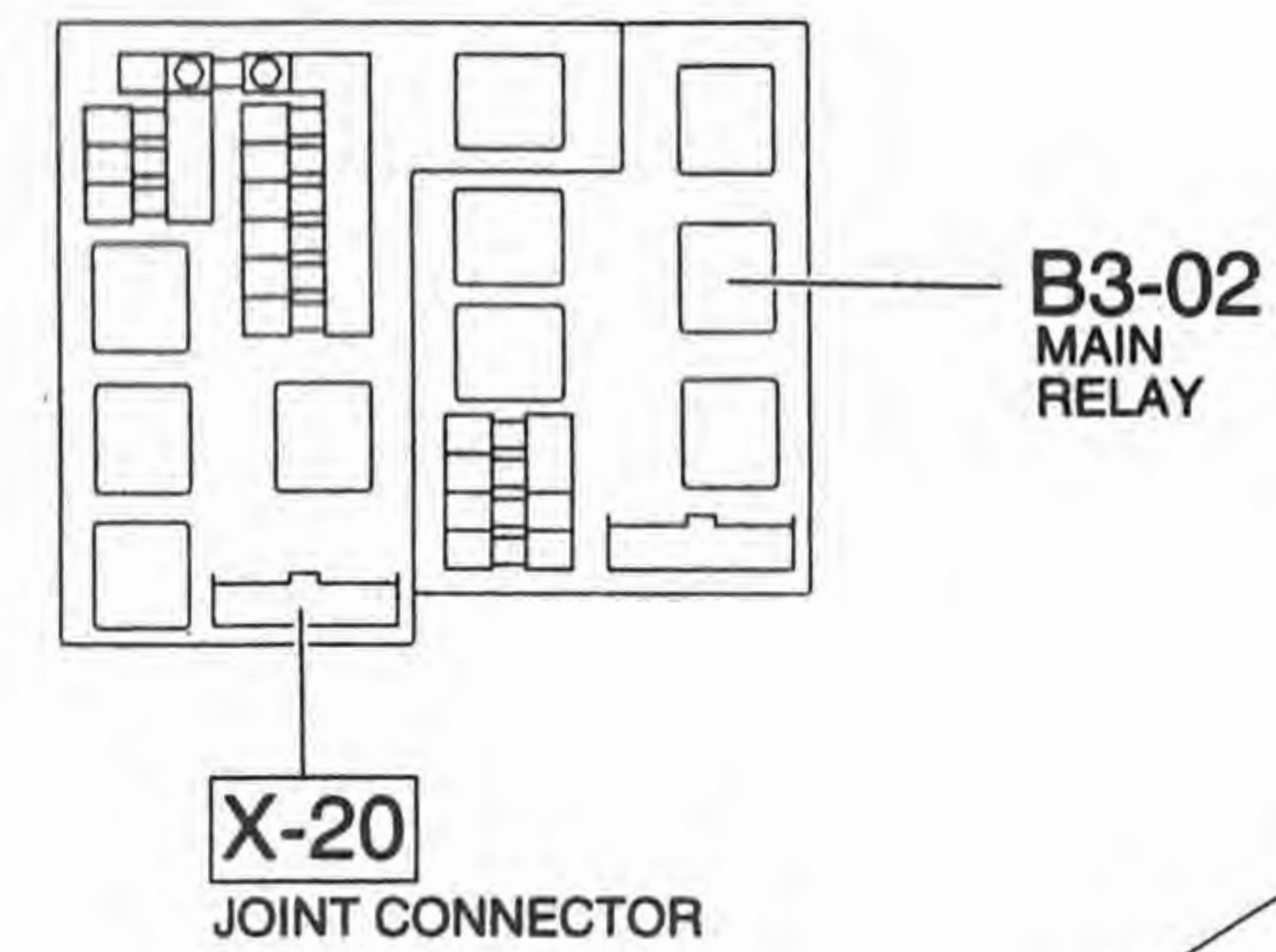
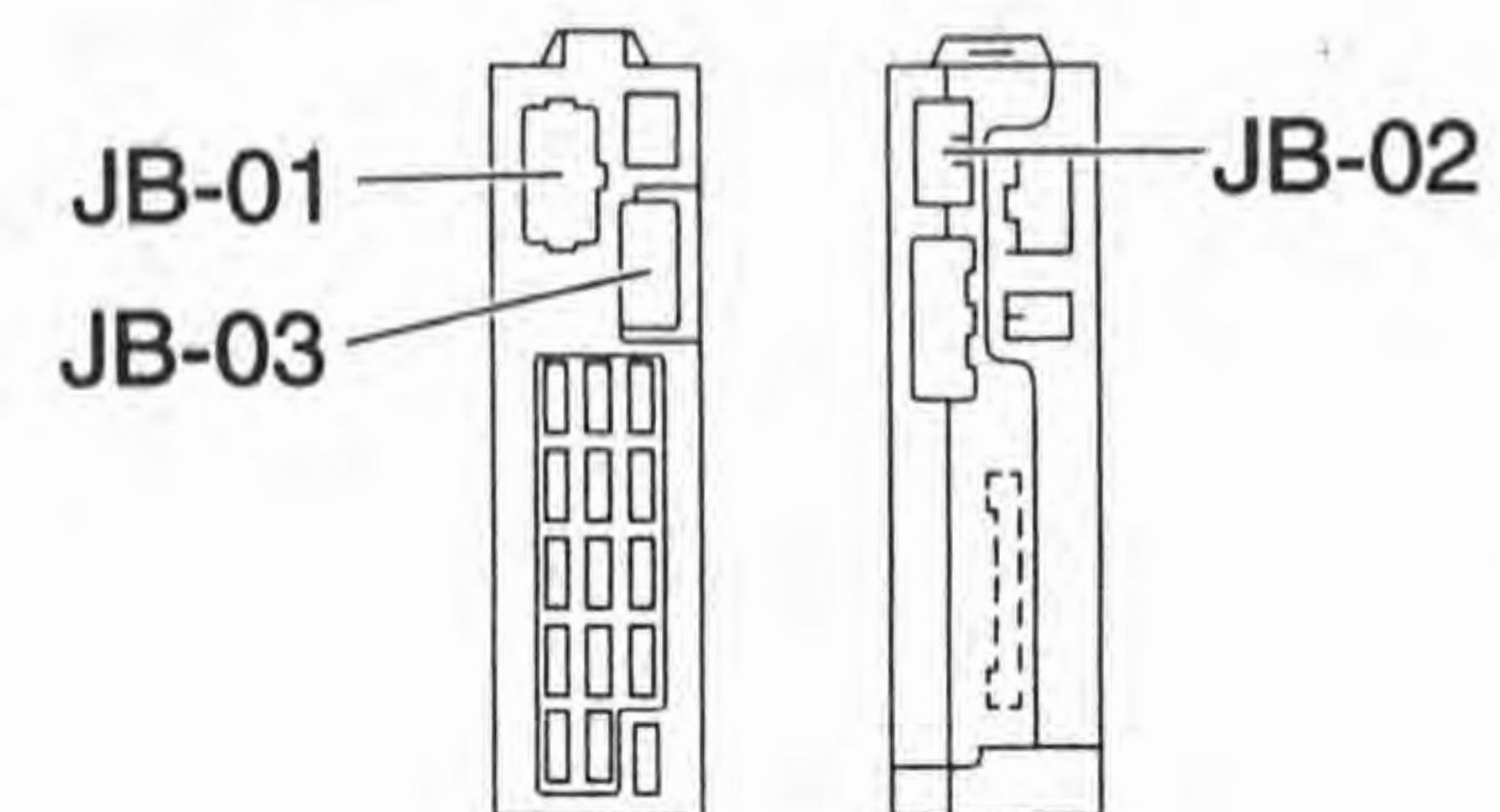

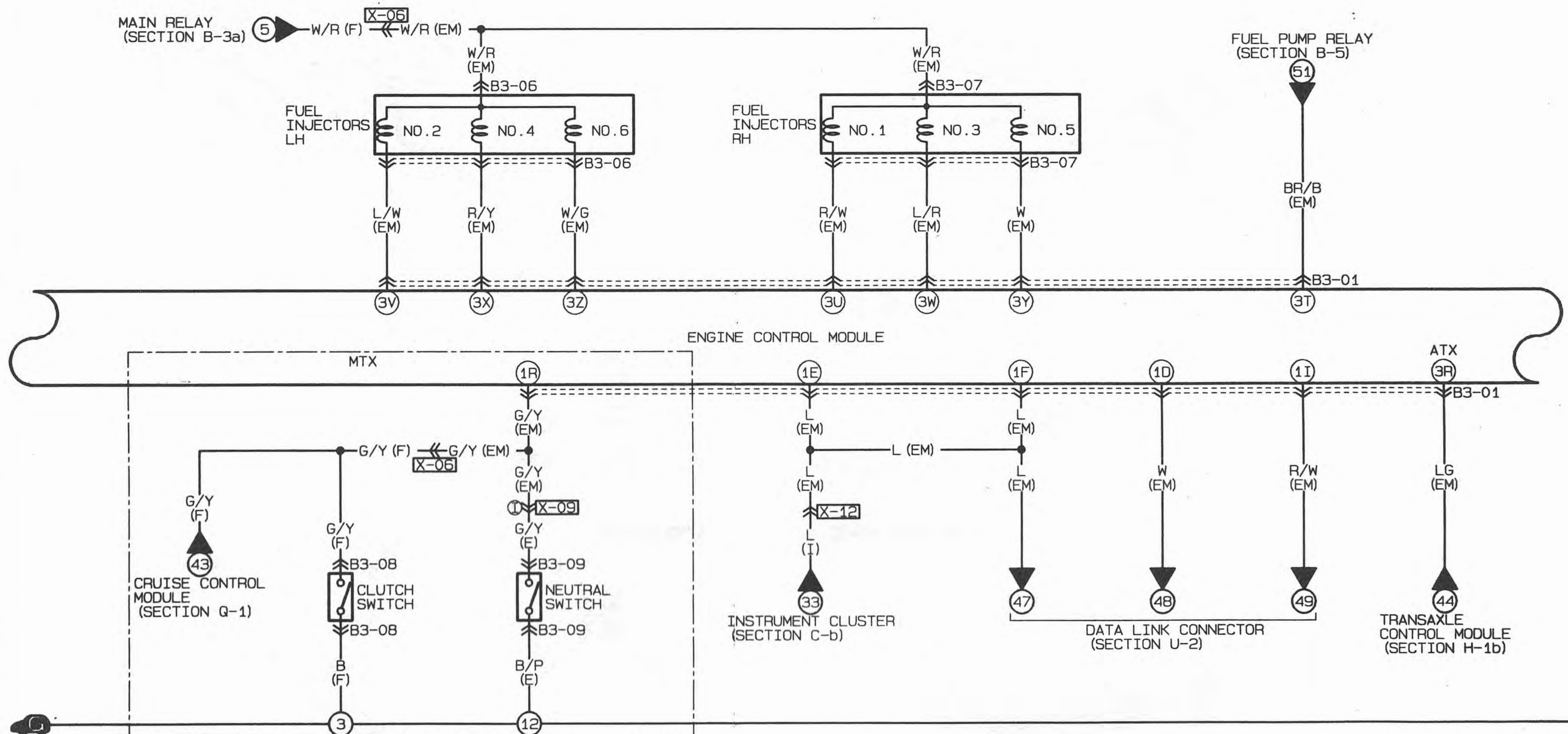

B3-01 ENGINE CONTROL MODULE (EM)

1U	1S	1Q	1O	1M	1K	1I	1G	1E	1C	1A
B/R (*)	*(BR/W)	W/G	G/B	G/R	*(Y/L)	R/W	Y/B	L	B/L	L/R
*(L)	BR	G/Y	L/B	L/Y	G/W	V	W	L	W	R/B
1V	1T	1R	1P	1N	1L	1J	1H	1F	1D	1B

20	2M	2K	2I	2G	2E	2C	2A
L/W	W	GY/B	G/L	*	R/G	Y	*(G/O)
W/B	*	B/Y (G)	R/B	W/R	P/G	G	R
2P	2N	2L	2J	2H	2F	2D	2B

3Y	3W	3U	3S	3Q	3O	3M	3K	3I	3G	3E	3C	3A
W	L/R	R/W	*	GY/R	P/B	GY/G	*	GY	P	LG (*)	B/R	B
W/G	R/Y	L/W	BR/B	*(L,G)	W/L	R	L/O	L/R	G	L	B/L	B
3Z	3X	3V	3T	3R	3P	3N	3L	3J	3H	3F	3D	3B

B3-06 FUEL INJECTORS LH (EM)



B3-07 FUEL INJECTORS RH (EM)



B3-08 CLUTCH SWITCH (F)

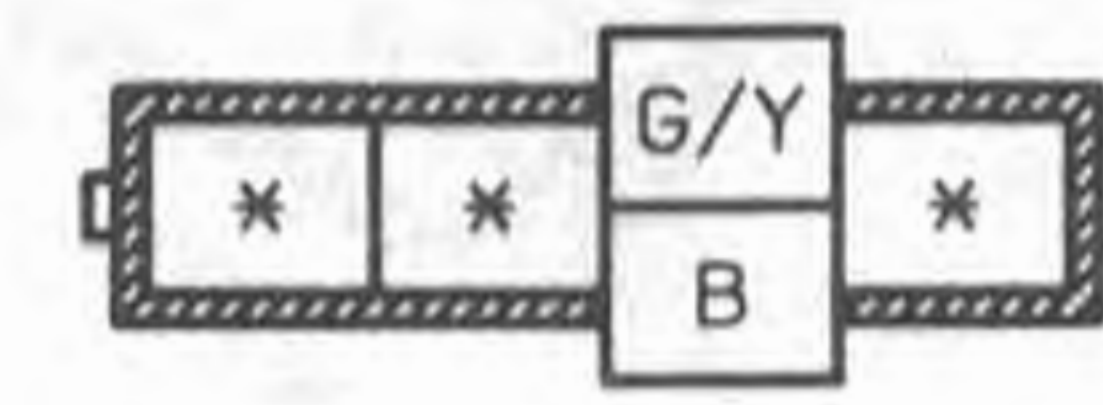

B3-09 NEUTRAL SWITCH (E)



B-3b

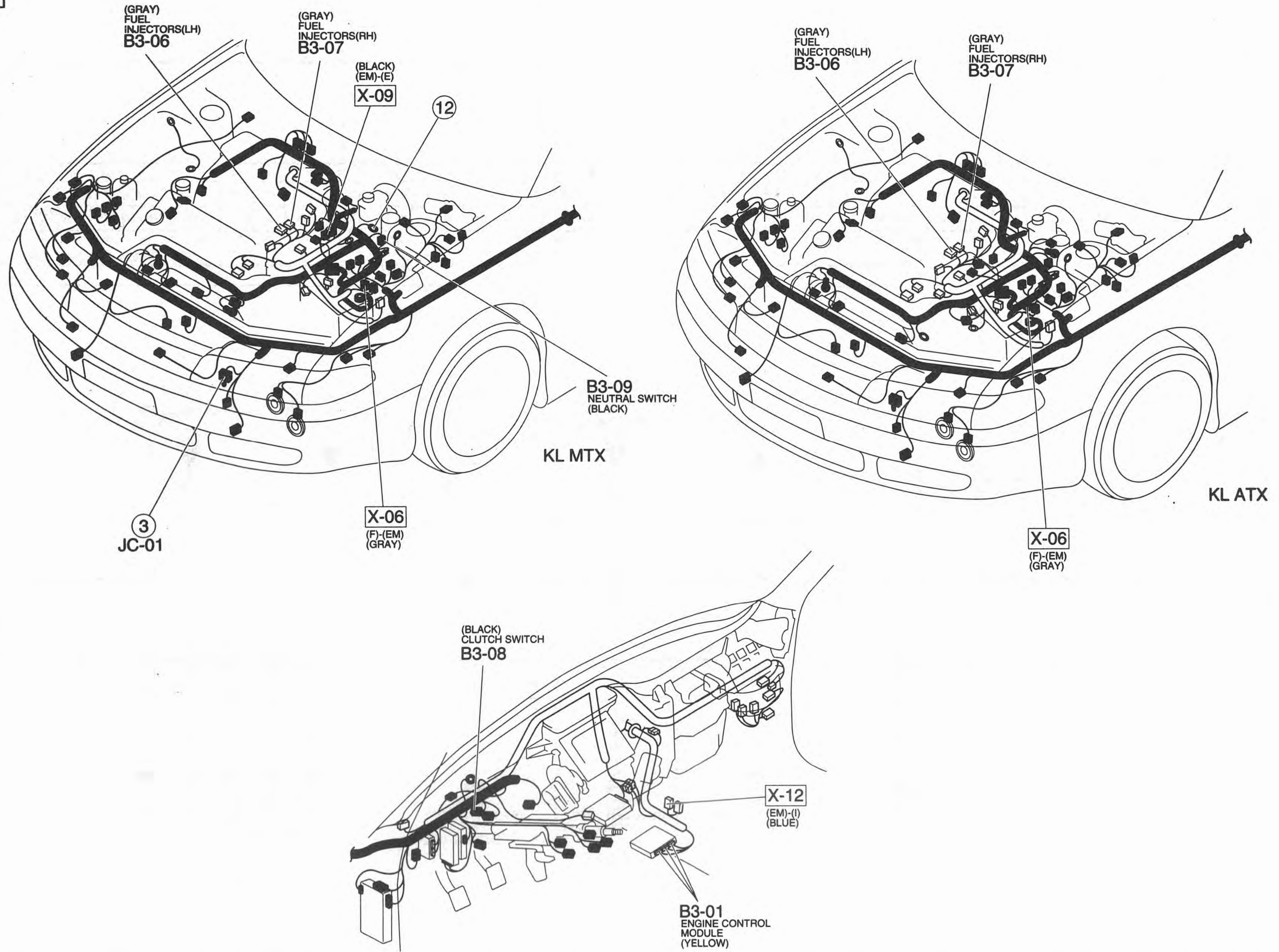

B-3c

KL

ENGINE CONTROL SYSTEM

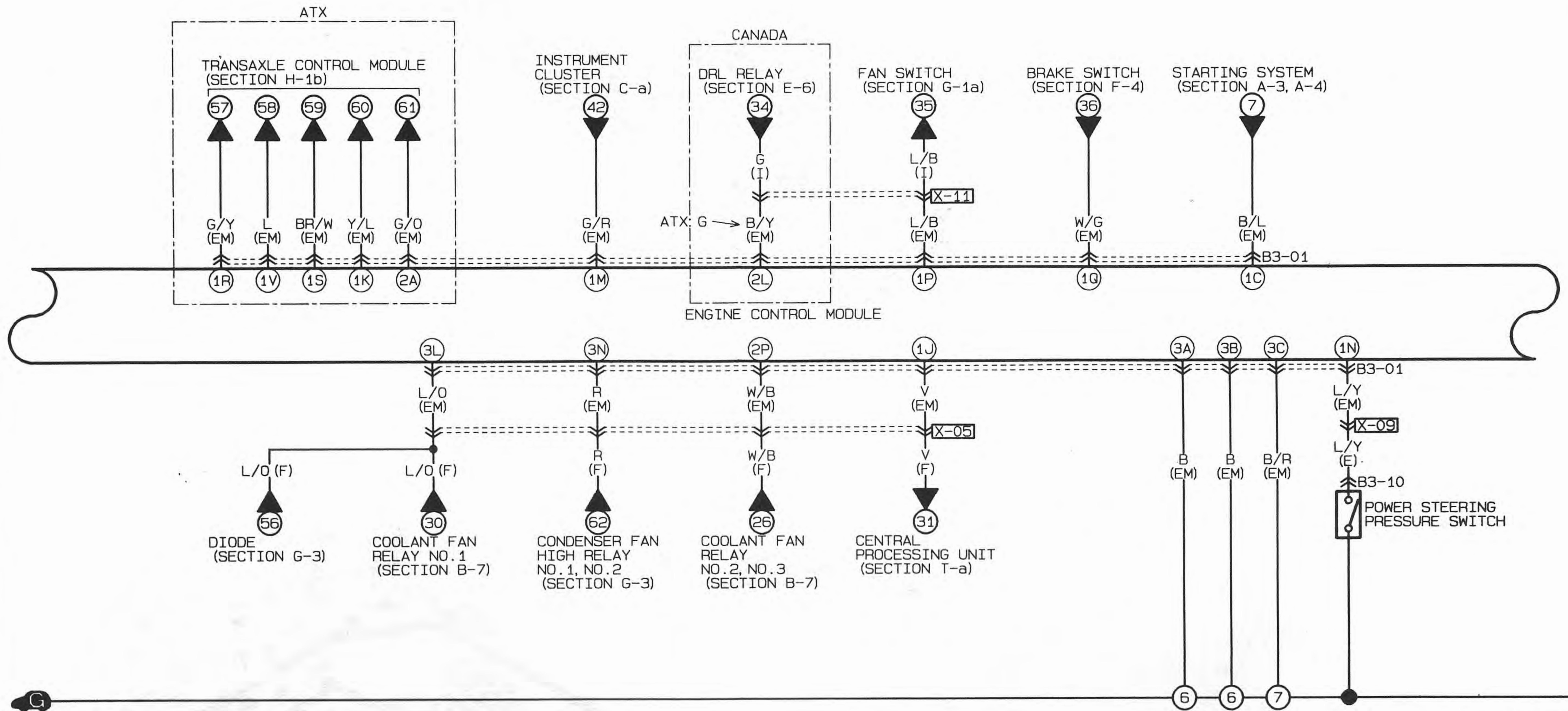

B3-01 ENGINE CONTROL MODULE (EM)

1U	1S	1Q	1O	1M	1K	1I	1G	1E	1C	1A
B/R (*)	* (BR/W)	W/G	G/B	G/R	* (Y/L)	R/W	Y/B	L	B/L	L/R
* (L)	BR	G/Y	L/B	L/Y	G/W	V	W	L	W	R/B
1V	1T	1R	1P	1N	1L	1J	1H	1F	1D	1B

2O	2M	2K	2I	2G	2E	2C	2A
L/W	W	GY/B	G/L	*	R/G	Y	* (G/O)
W/B	*	B/Y (G)	R/B	W/R	P/G	G	R
2P	2N	2L	2J	2H	2F	2D	2B

3Y	3W	3U	3S	3Q	3O	3M	3K	3I	3G	3E	3C	3A
W	L/R	R/W	*	GY/R	P/B	GY/G	*	GY	P	LG (*)	B/R	B
W/G	R/Y	L/W	BR/B	* (LG)	W/L	R	L/O	L/R	G	L	B/L	B
3Z	3X	3V	3T	3R	3P	3N	3L	3J	3H	3F	3D	3B

B3-10 POWER STEERING PRESSURE SWITCH (E)

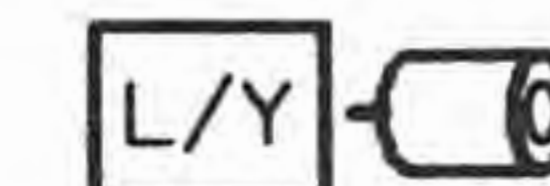

B-3c

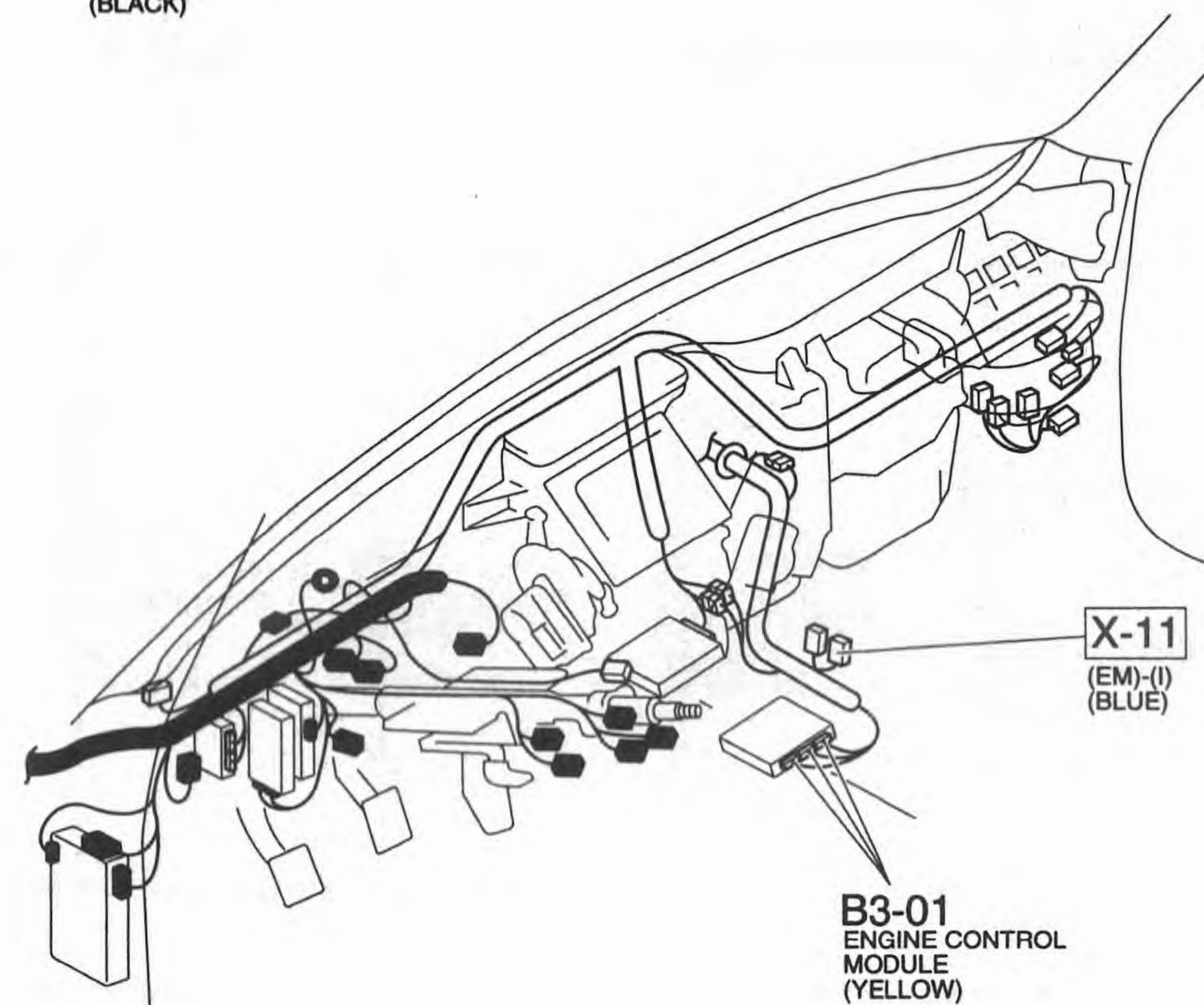
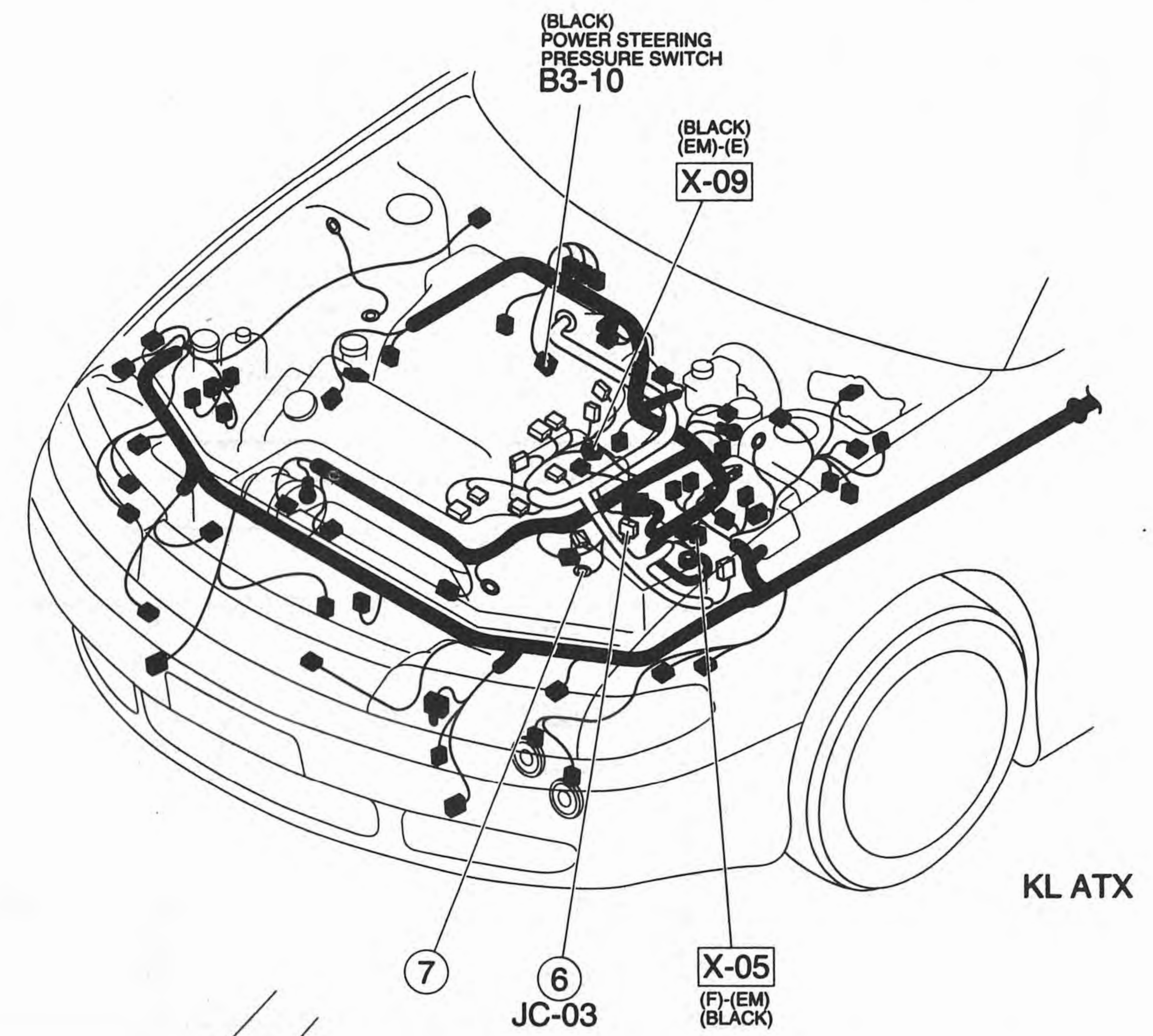
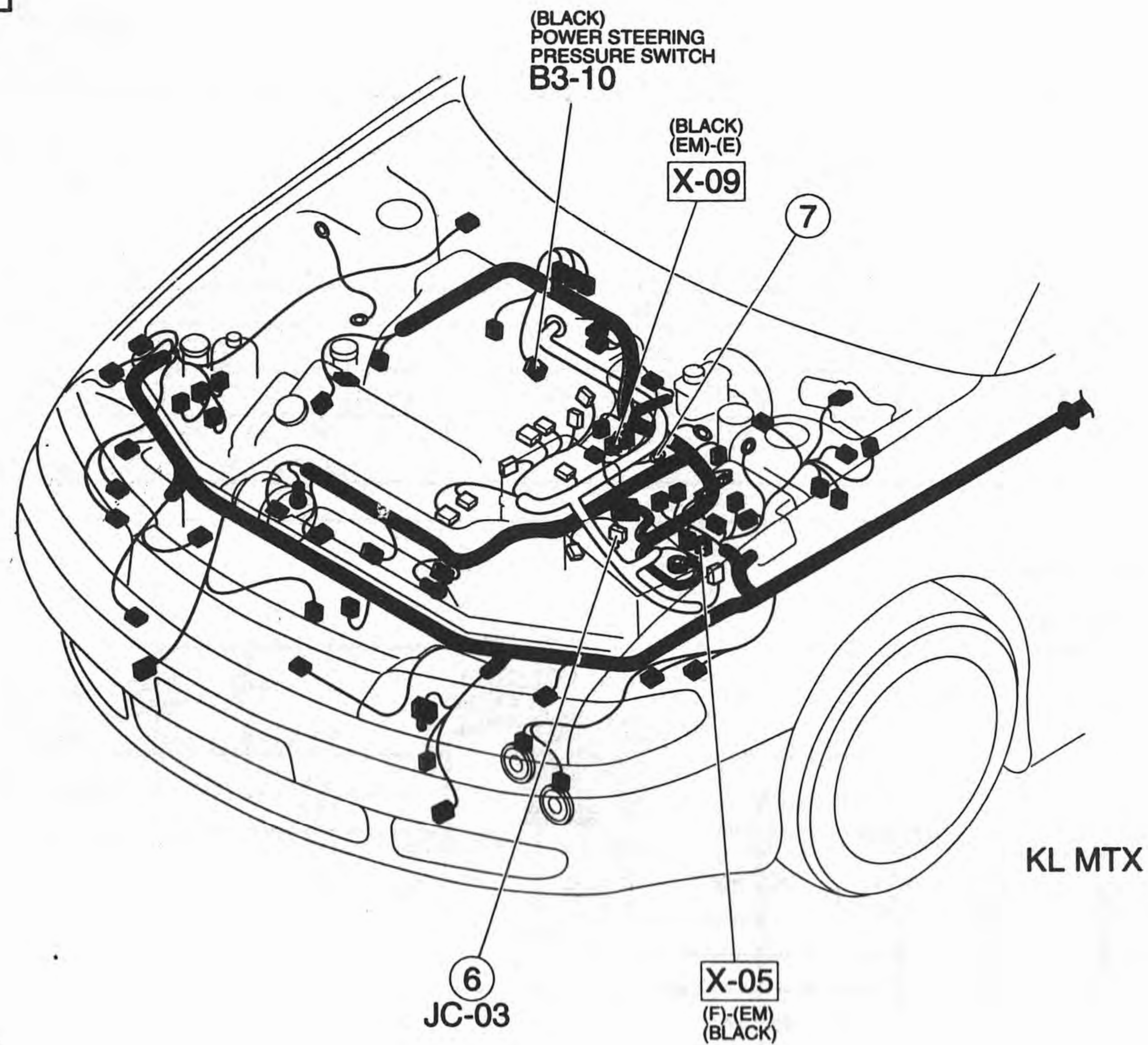

B-3d

KL

ENGINE CONTROL SYSTEM

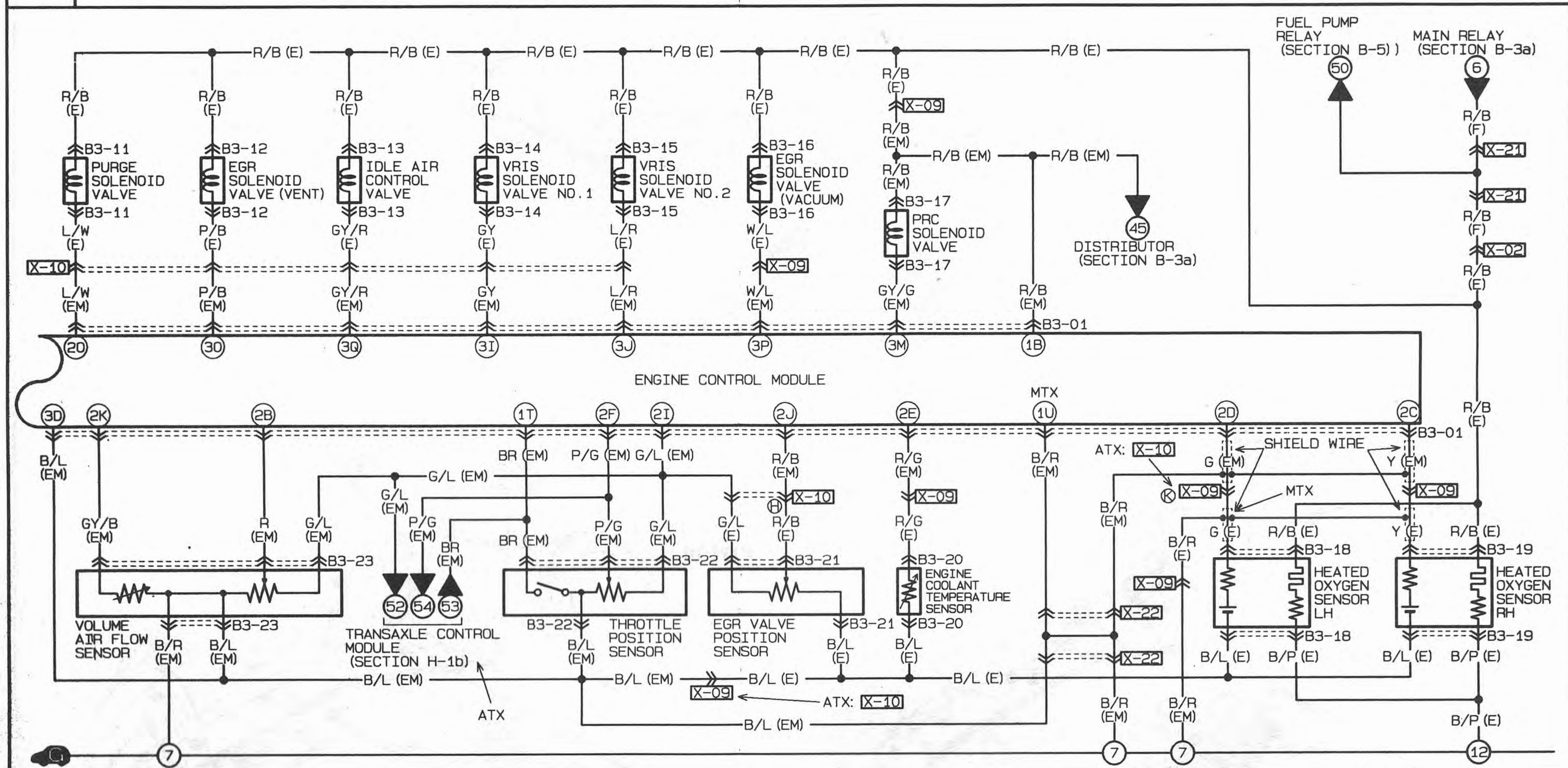

B3-01 ENGINE CONTROL MODULE (EM) <table border="1"> <tr> <td>1U</td><td>1S</td><td>1G</td><td>1O</td><td>1M</td><td>1K</td><td>1I</td><td>1G</td><td>1E</td><td>1C</td><td>1A</td> <td>20</td><td>2M</td><td>2K</td><td>2I</td><td>2G</td><td>2E</td><td>2C</td><td>2A</td> <td>3Y</td><td>3W</td><td>3U</td><td>3S</td><td>3Q</td><td>3O</td><td>3M</td><td>3K</td><td>3I</td><td>3G</td><td>3E</td><td>3C</td><td>3A</td> </tr> <tr> <td>B/R (*)</td><td>* (BR/W)</td><td>W/G</td><td>G/B</td><td>G/R</td><td>* (Y/L)</td><td>R/W</td><td>Y/B</td><td>L</td><td>B/L</td><td>L/R</td> <td>L/W</td><td>W</td><td>GY/B</td><td>G/L</td><td>*</td><td>R/G</td><td>Y</td><td>* (G/O)</td> <td>W</td><td>L/R</td><td>R/W</td><td>*</td><td>GY/R</td><td>P/B</td><td>GY/G</td><td>*</td><td>GY</td><td>P</td><td>LG (*)</td><td>B/R</td><td>B</td> </tr> <tr> <td>* (L)</td><td>BR</td><td>G/Y</td><td>L/B</td><td>L/Y</td><td>G/W</td><td>V</td><td>W</td><td>L</td><td>W</td><td>R/B</td> <td>W/B</td><td>*</td><td>B/Y (G)</td><td>R/B</td><td>W/R</td><td>P/G</td><td>G</td><td>R</td> <td>W/G</td><td>R/Y</td><td>L/W</td><td>BR/B</td><td>* (LG)</td><td>W/L</td><td>R</td><td>L/O</td><td>L/R</td><td>G</td><td>L</td><td>B/L</td><td>B</td> </tr> <tr> <td>1V</td><td>1T</td><td>1R</td><td>1P</td><td>1N</td><td>1L</td><td>1J</td><td>1H</td><td>1F</td><td>1D</td><td>1B</td> <td>2P</td><td>2N</td><td>2L</td><td>2J</td><td>2H</td><td>2F</td><td>2D</td><td>2B</td> <td>3Z</td><td>3X</td><td>3V</td><td>3T</td><td>3R</td><td>3P</td><td>3N</td><td>3L</td><td>3J</td><td>3H</td><td>3F</td><td>3D</td><td>3B</td> </tr> </table>										1U	1S	1G	1O	1M	1K	1I	1G	1E	1C	1A	20	2M	2K	2I	2G	2E	2C	2A	3Y	3W	3U	3S	3Q	3O	3M	3K	3I	3G	3E	3C	3A	B/R (*)	* (BR/W)	W/G	G/B	G/R	* (Y/L)	R/W	Y/B	L	B/L	L/R	L/W	W	GY/B	G/L	*	R/G	Y	* (G/O)	W	L/R	R/W	*	GY/R	P/B	GY/G	*	GY	P	LG (*)	B/R	B	* (L)	BR	G/Y	L/B	L/Y	G/W	V	W	L	W	R/B	W/B	*	B/Y (G)	R/B	W/R	P/G	G	R	W/G	R/Y	L/W	BR/B	* (LG)	W/L	R	L/O	L/R	G	L	B/L	B	1V	1T	1R	1P	1N	1L	1J	1H	1F	1D	1B	2P	2N	2L	2J	2H	2F	2D	2B	3Z	3X	3V	3T	3R	3P	3N	3L	3J	3H	3F	3D	3B	B3-11 PURGE SOLENOID VALVE (E)
1U	1S	1G	1O	1M	1K	1I	1G	1E	1C	1A	20	2M	2K	2I	2G	2E	2C	2A	3Y	3W	3U	3S	3Q	3O	3M	3K	3I	3G	3E	3C	3A																																																																																																											
B/R (*)	* (BR/W)	W/G	G/B	G/R	* (Y/L)	R/W	Y/B	L	B/L	L/R	L/W	W	GY/B	G/L	*	R/G	Y	* (G/O)	W	L/R	R/W	*	GY/R	P/B	GY/G	*	GY	P	LG (*)	B/R	B																																																																																																											
* (L)	BR	G/Y	L/B	L/Y	G/W	V	W	L	W	R/B	W/B	*	B/Y (G)	R/B	W/R	P/G	G	R	W/G	R/Y	L/W	BR/B	* (LG)	W/L	R	L/O	L/R	G	L	B/L	B																																																																																																											
1V	1T	1R	1P	1N	1L	1J	1H	1F	1D	1B	2P	2N	2L	2J	2H	2F	2D	2B	3Z	3X	3V	3T	3R	3P	3N	3L	3J	3H	3F	3D	3B																																																																																																											
B3-12 EGR SOLENOID VALVE (VENT) (E) 	B3-13 IDLE AIR CONTROL VALVE (E) 	B3-14 VRIS SOLENOID VALVE NO. 1 (E) 	B3-15 VRIS SOLENOID VALVE NO. 2 (E) 	B3-16 EGR SOLENOID VALVE (VACUUM) (E) 	B3-17 PRC SOLENOID VALVE (EM) 	B3-18 HEATED OXYGEN SENSOR LH (E) 																																																																																																																																				
B3-19 HEATED OXYGEN SENSOR RH (E) 	B3-20 ENGINE COOLANT TEMPERATURE SENSOR (E) 	B3-21 EGR VALVE POSITION SENSOR (E) 	B3-22 THROTTLE POSITION SENSOR (EM) 	B3-23 VOLUME AIR FLOW SENSOR (EM) 																																																																																																																																						

B-3d

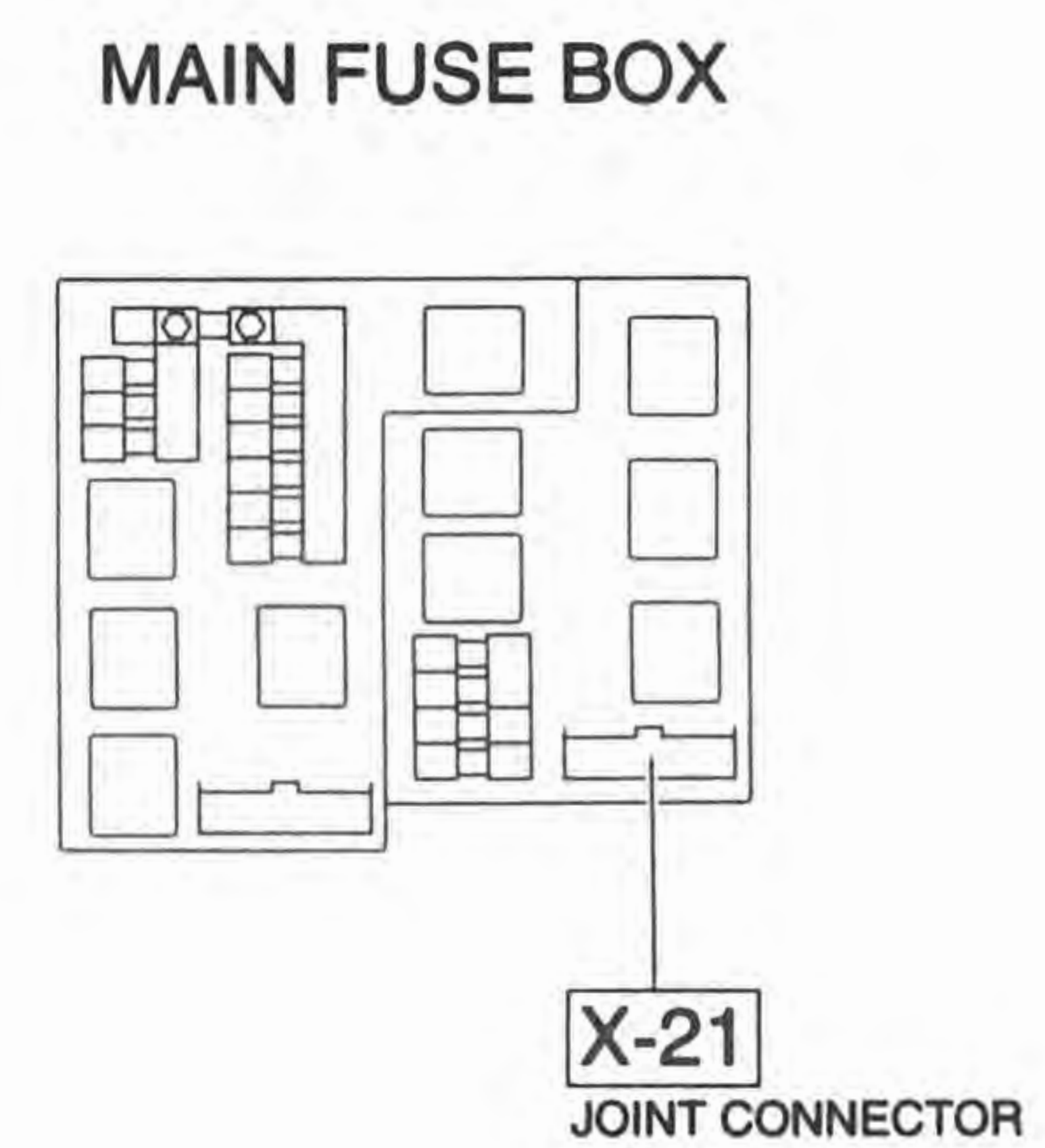
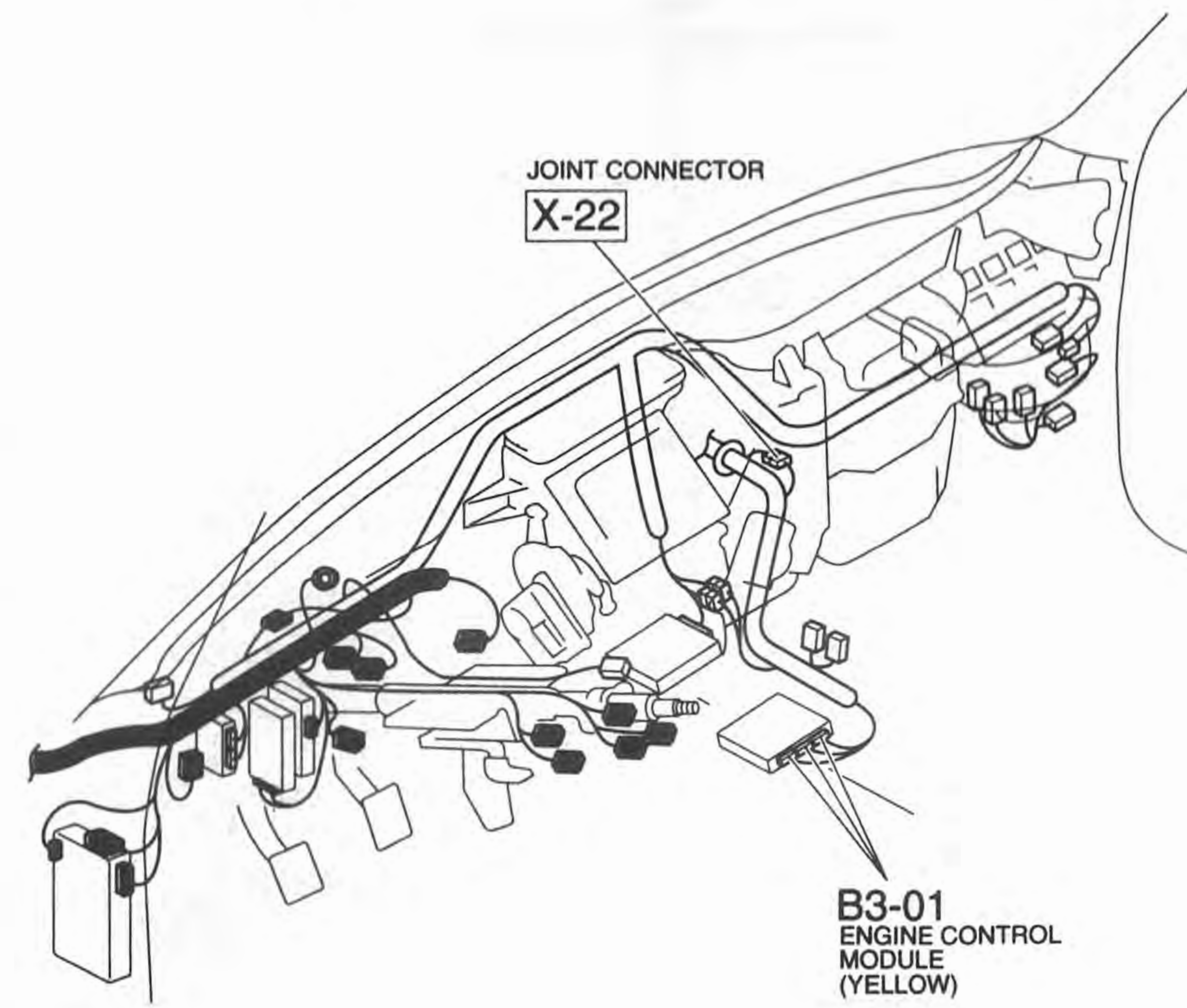
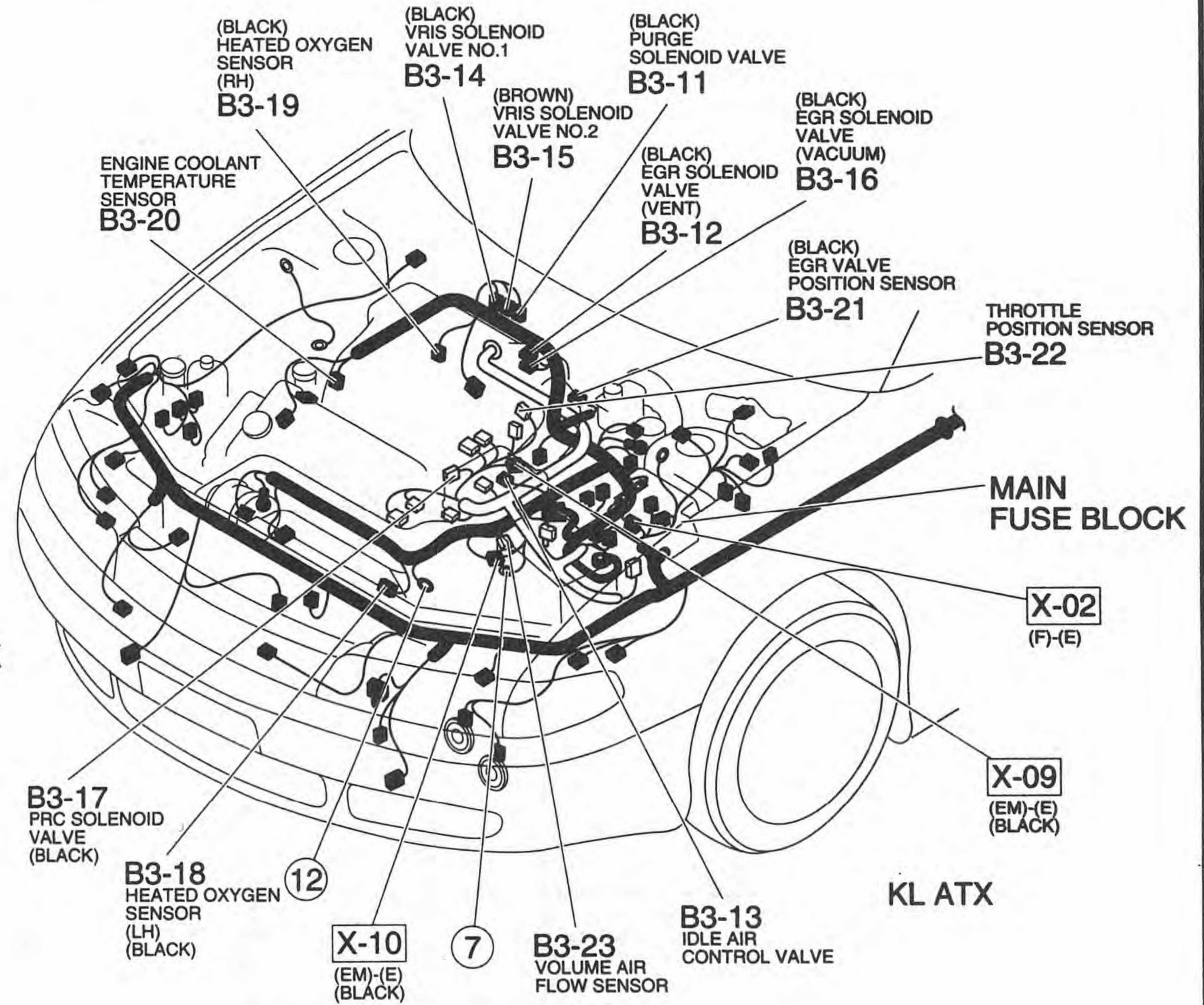
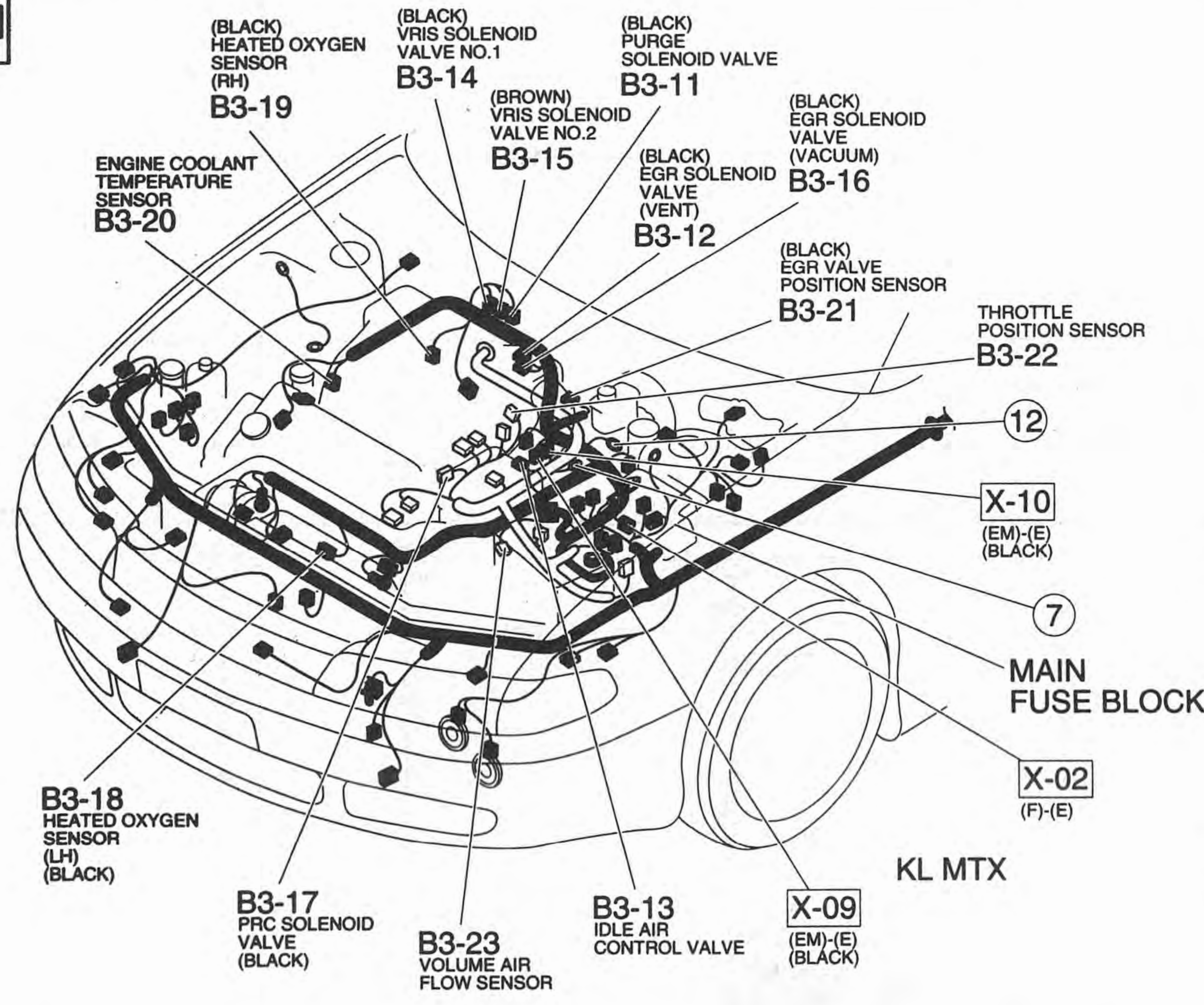

B-4

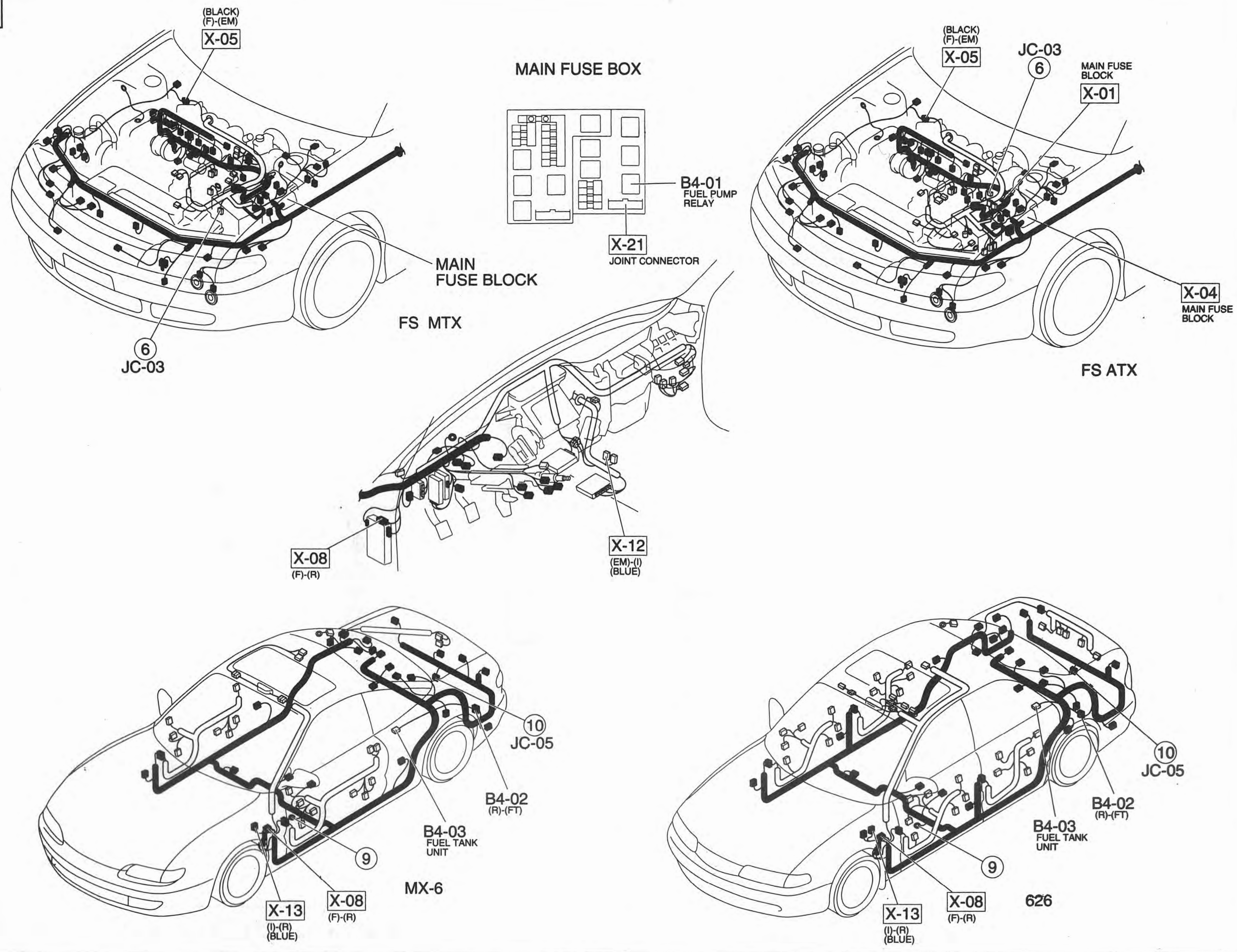

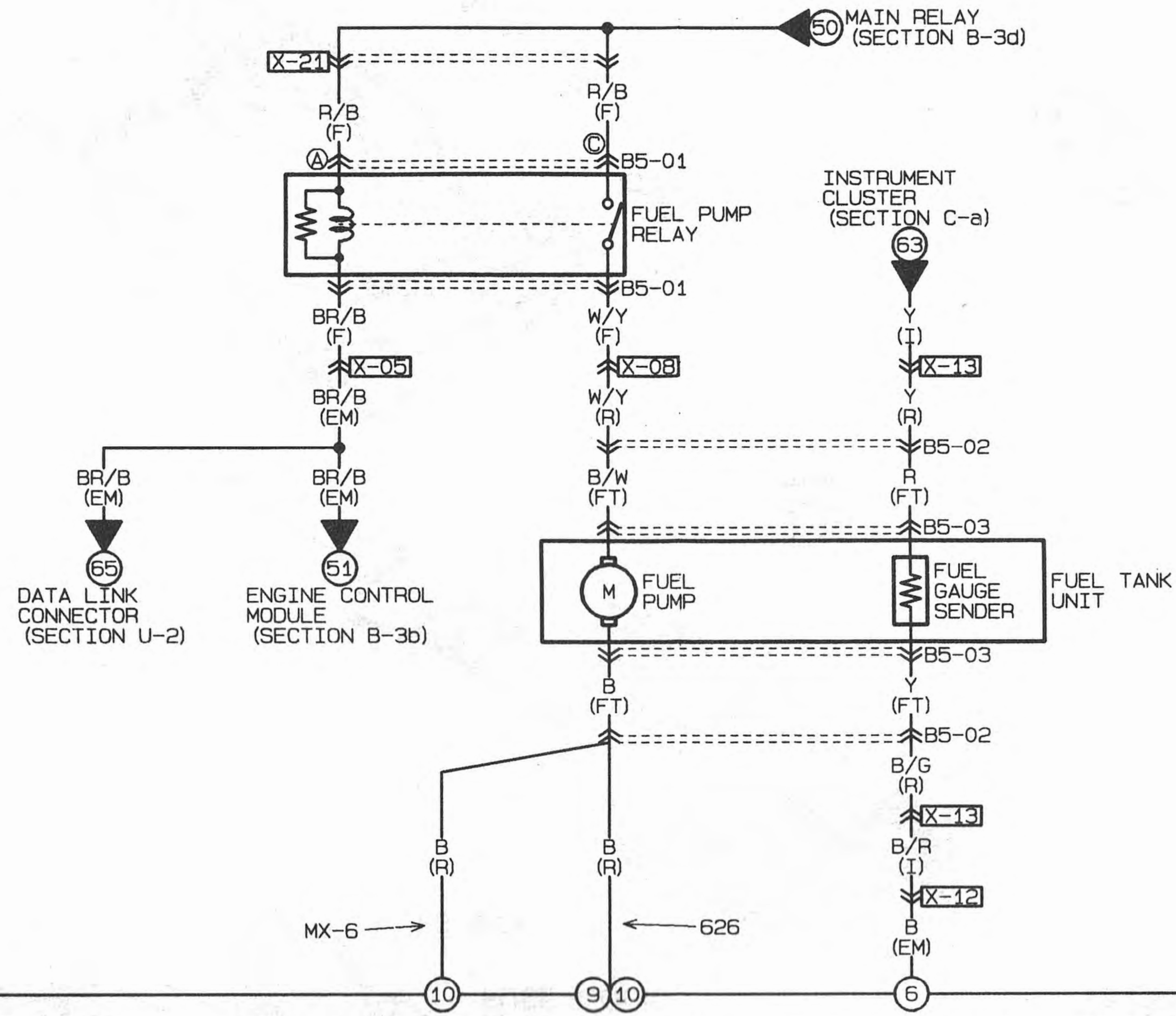

B5-01 FUEL PUMP RELAY (F)

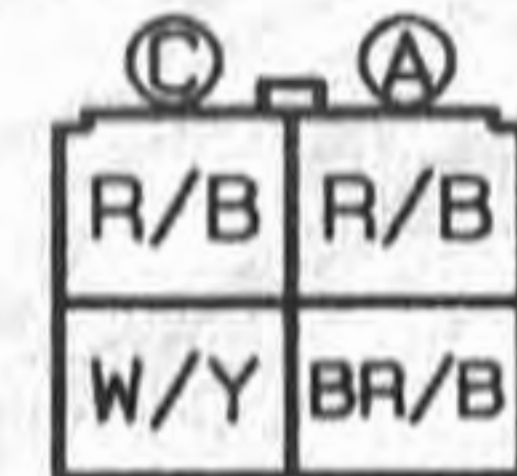

B5-02 REAR (R) - FUEL TANK UNIT (FT)

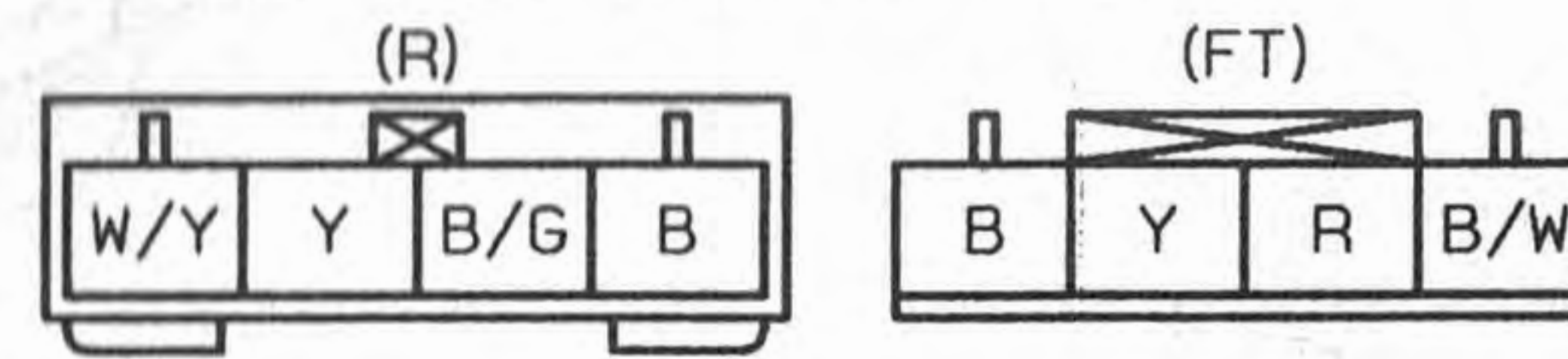

B5-03 FUEL TANK UNIT (FT)



B-5

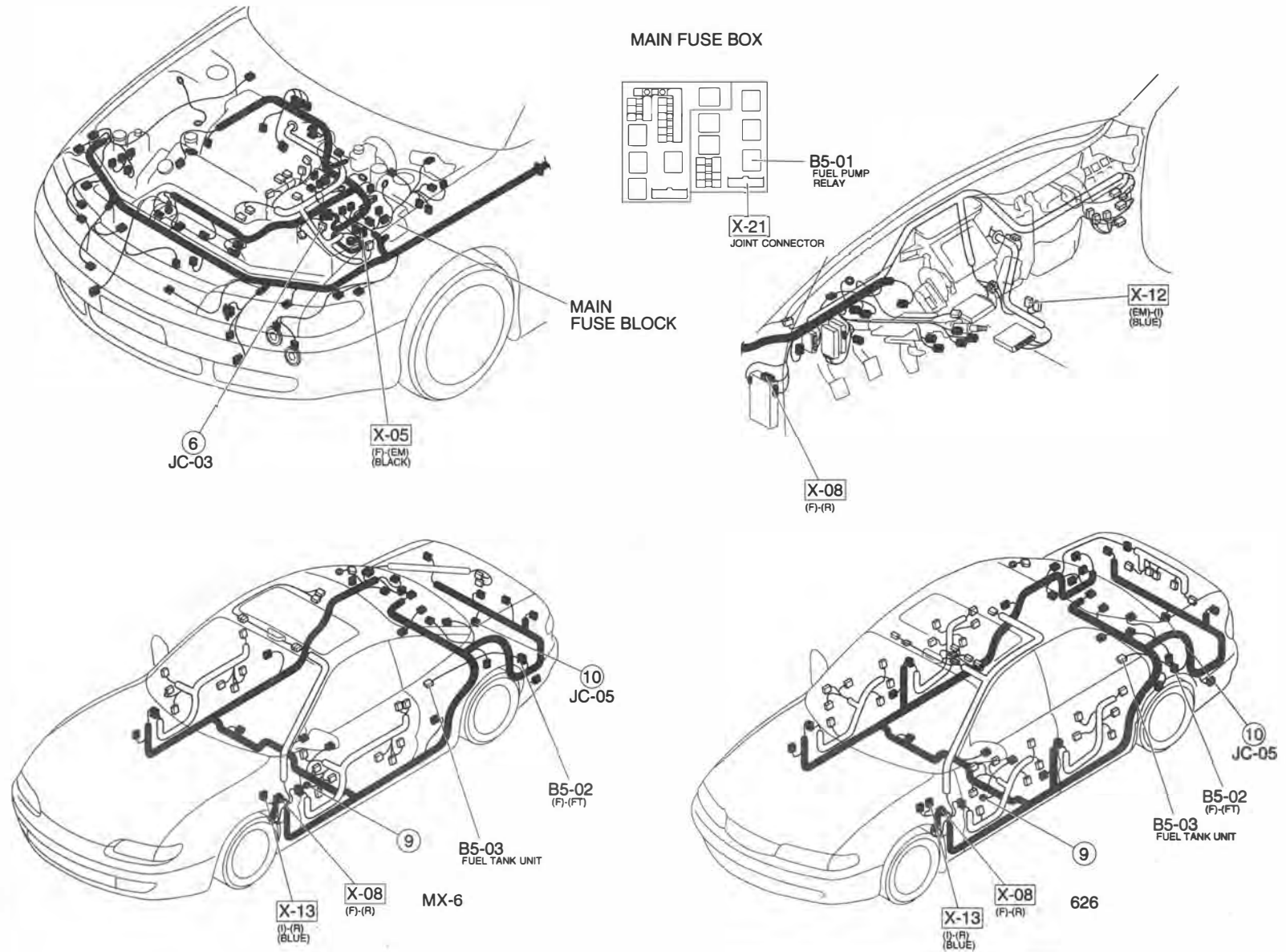

B-6 FS ■ COOLANT FAN SYSTEM

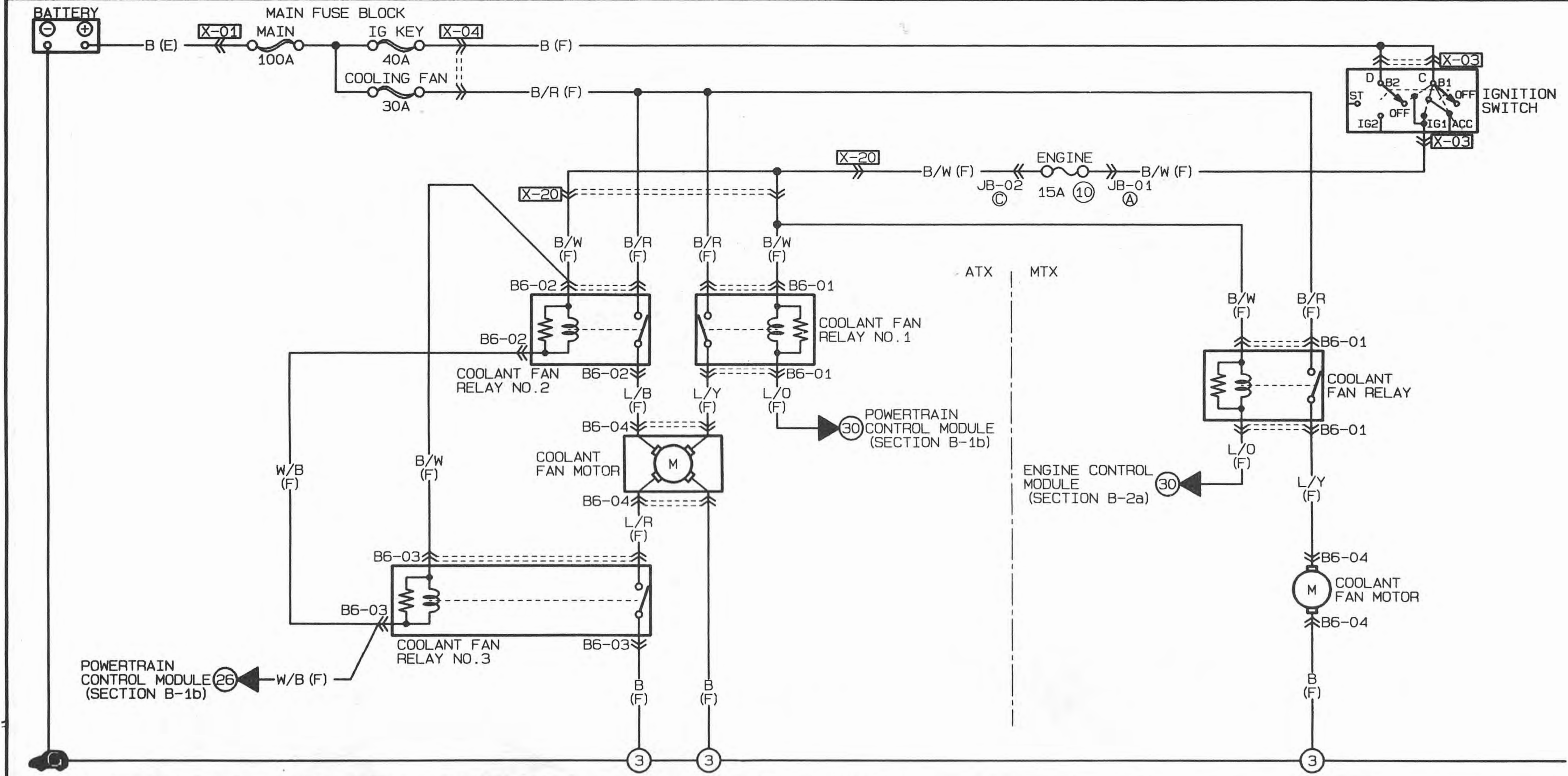

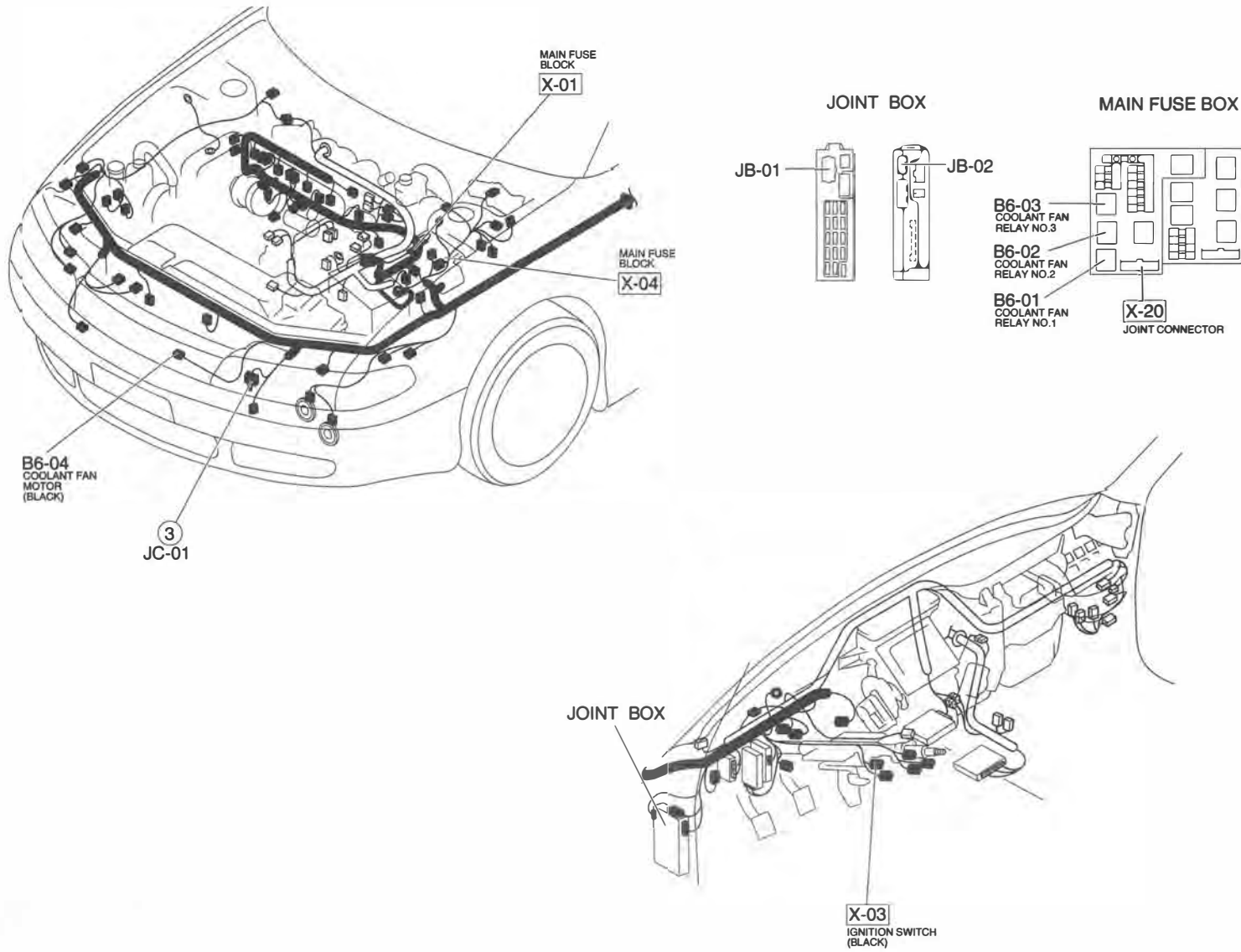

<p>B6-01 COOLANT FAN RELAY NO. 1 (F)</p> <table border="1"> <tr> <td>B/R</td> <td>B/W</td> </tr> <tr> <td>L/Y</td> <td>L/O</td> </tr> </table>	B/R	B/W	L/Y	L/O	<p>B6-02 COOLANT FAN RELAY NO. 2 (F)</p> <table border="1"> <tr> <td>B/R</td> <td>B/W</td> </tr> <tr> <td>L/B</td> <td>W/B</td> </tr> </table>	B/R	B/W	L/B	W/B	<p>B6-03 COOLANT FAN RELAY NO. 3 (F)</p> <table border="1"> <tr> <td>L/R</td> <td>B/W</td> </tr> <tr> <td>B</td> <td>W/B</td> </tr> </table>	L/R	B/W	B	W/B	<p>B6-04 COOLANT FAN MOTOR (F)</p> <table border="1"> <tr> <td>L/B</td> <td>L/Y</td> </tr> <tr> <td>L/R</td> <td>B</td> </tr> </table> <p>ATX</p>	L/B	L/Y	L/R	B	<table border="1"> <tr> <td>*</td> <td>L/Y</td> </tr> <tr> <td>*</td> <td>B</td> </tr> </table> <p>MTX</p>	*	L/Y	*	B		
B/R	B/W																									
L/Y	L/O																									
B/R	B/W																									
L/B	W/B																									
L/R	B/W																									
B	W/B																									
L/B	L/Y																									
L/R	B																									
*	L/Y																									
*	B																									

B-6

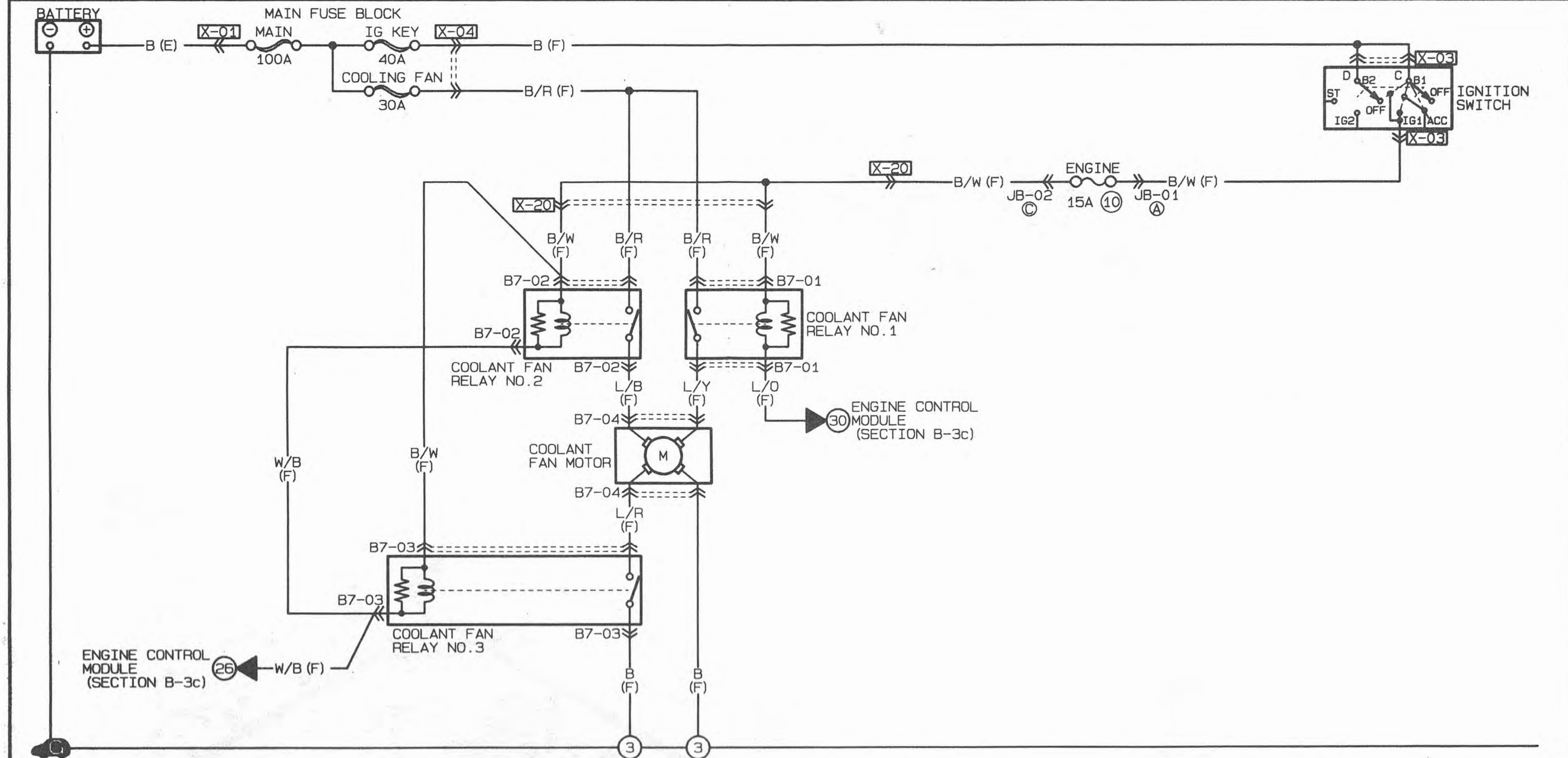

B-7 KL ■ COOLANT FAN SYSTEM



B7-01 COOLANT FAN RELAY NO. 1 (F)	B7-02 COOLANT FAN RELAY NO. 2 (F)	B7-03 COOLANT FAN RELAY NO. 3 (F)	B7-04 COOLANT FAN MOTOR (F)																		
<table border="1"> <tr><td>B/R</td><td>B/W</td></tr> <tr><td>L/Y</td><td>L/O</td></tr> </table>	B/R	B/W	L/Y	L/O	<table border="1"> <tr><td>B/R</td><td>B/W</td></tr> <tr><td>L/B</td><td>W/B</td></tr> </table>	B/R	B/W	L/B	W/B	<table border="1"> <tr><td>L/R</td><td>B/W</td></tr> <tr><td>B</td><td>W/B</td></tr> </table>	L/R	B/W	B	W/B	 <table border="1"> <tr><td>L/B</td><td>L/Y</td></tr> <tr><td>L/R</td><td>B</td></tr> </table>	L/B	L/Y	L/R	B		
B/R	B/W																				
L/Y	L/O																				
B/R	B/W																				
L/B	W/B																				
L/R	B/W																				
B	W/B																				
L/B	L/Y																				
L/R	B																				

B-7

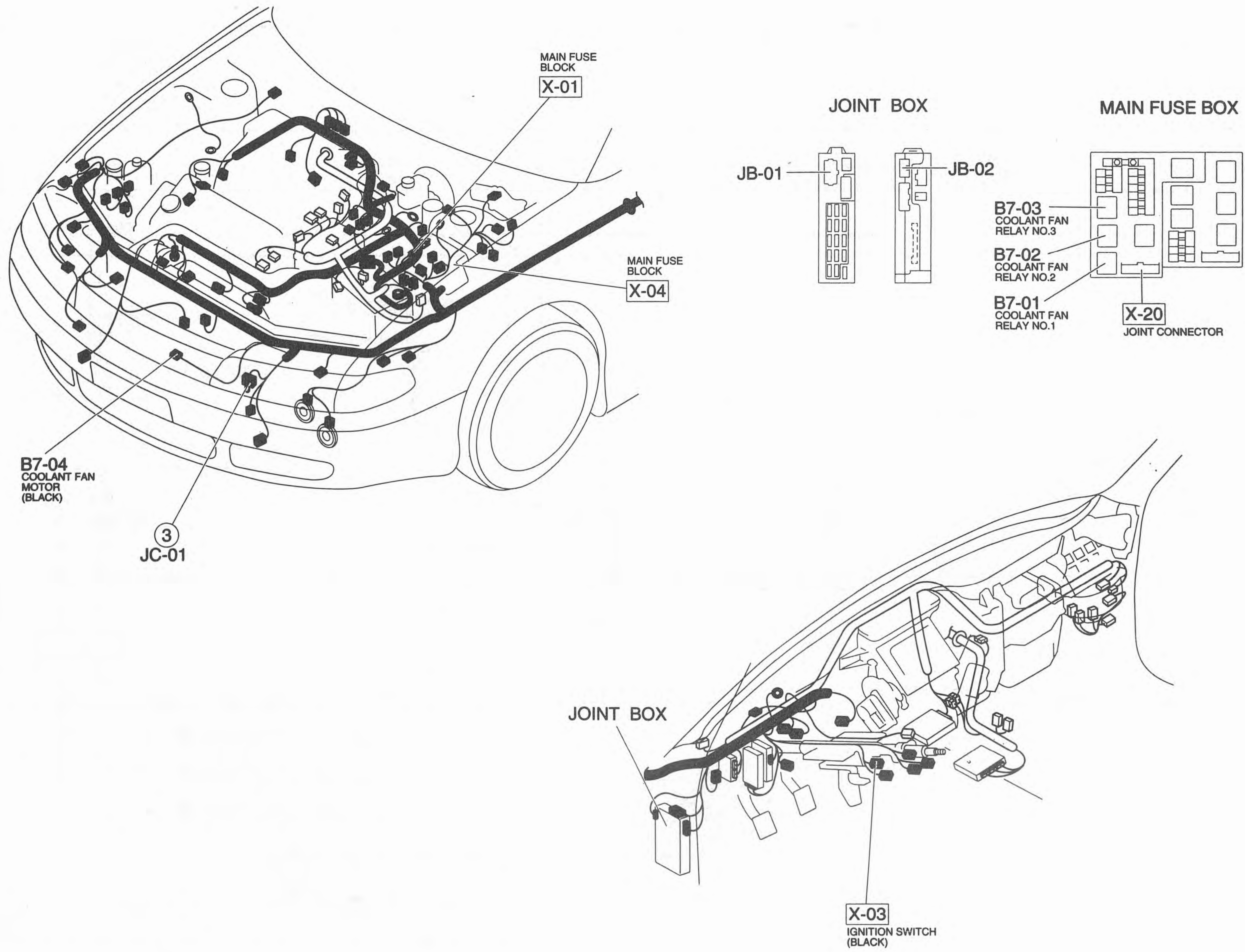

C-a INSTRUMENT CLUSTER

() ... ATX
*... CANADA



C-01 INSTRUMENT CLUSTER (I)

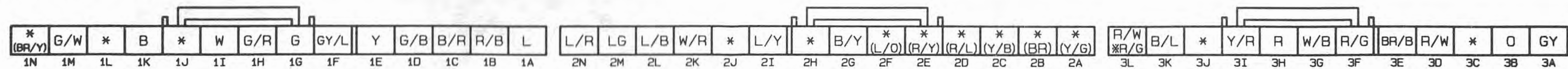

C-02 VEHICLE SPEEDOMETER SENSOR (E)



C-03 WATER TEMPERATURE SENSOR UNIT (E) ← KL



C-a

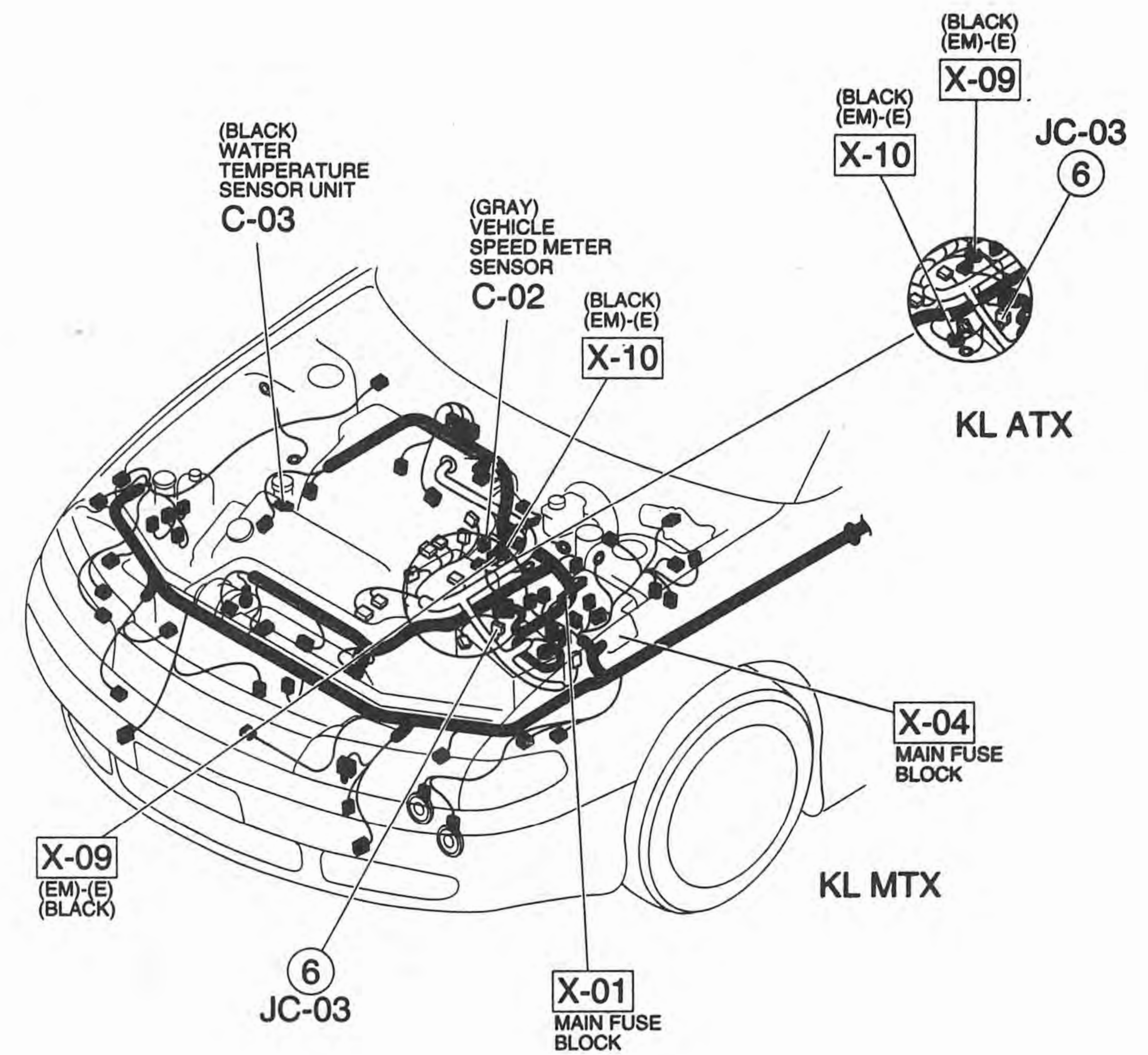
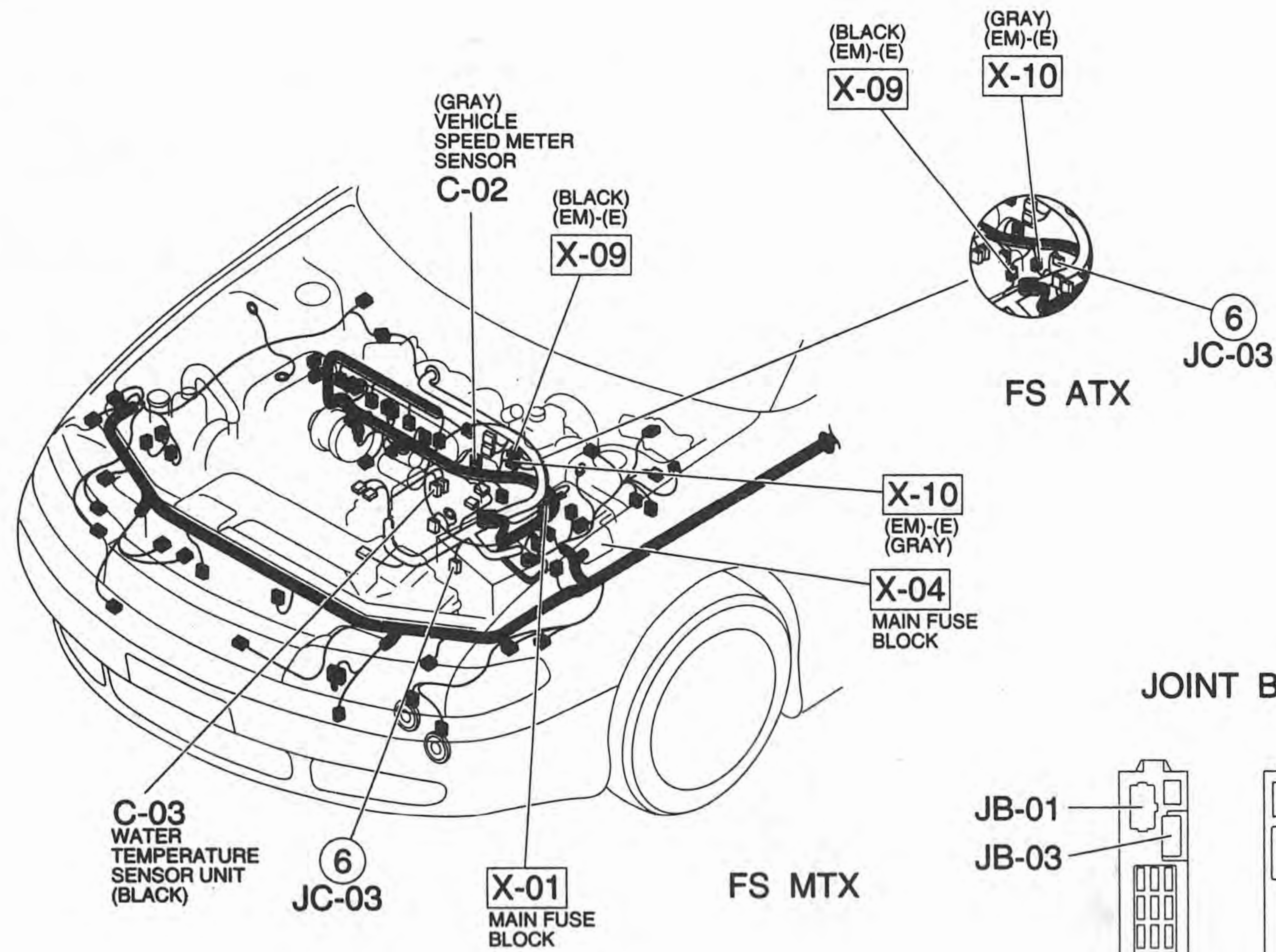

JOINT BOX

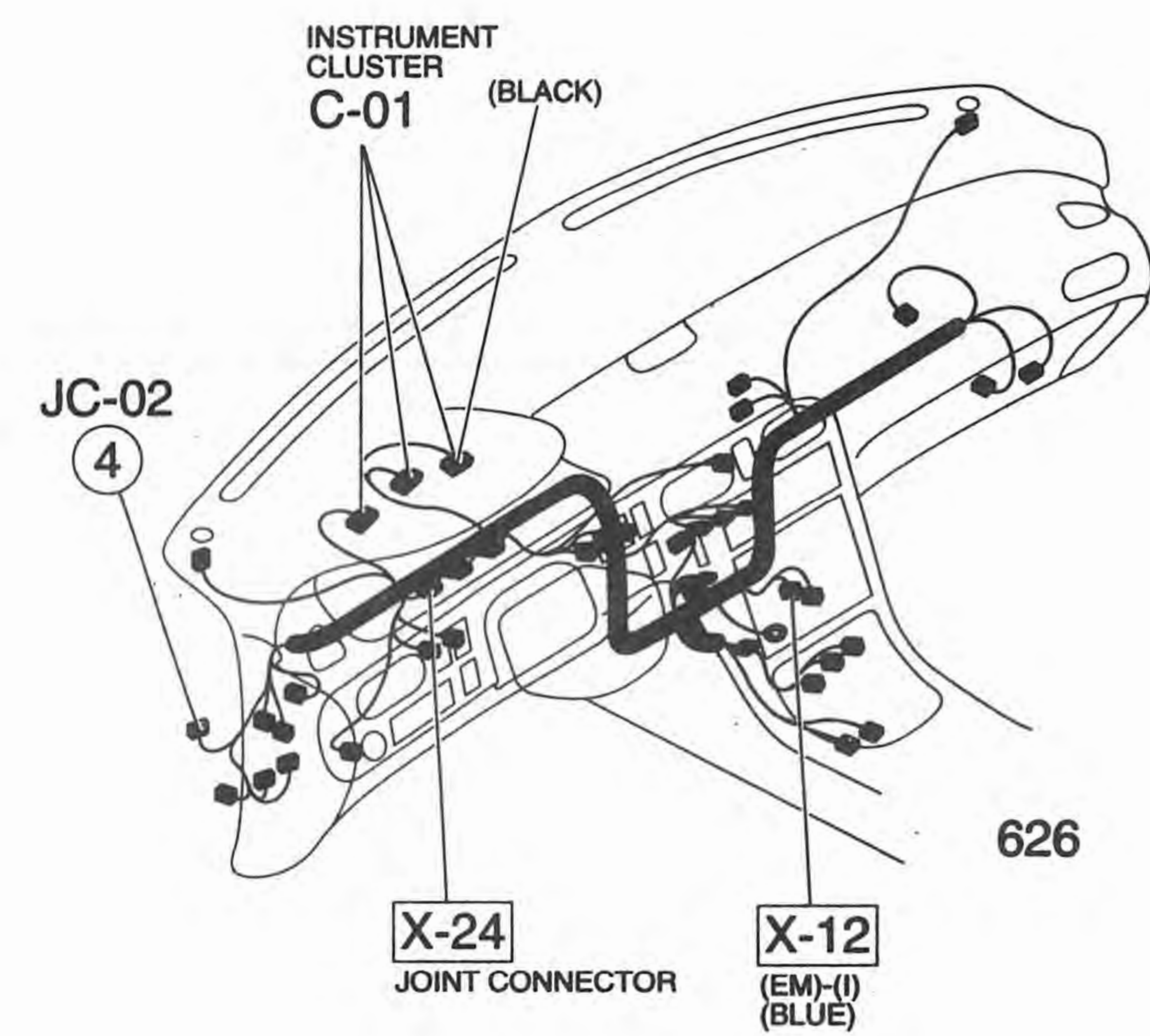
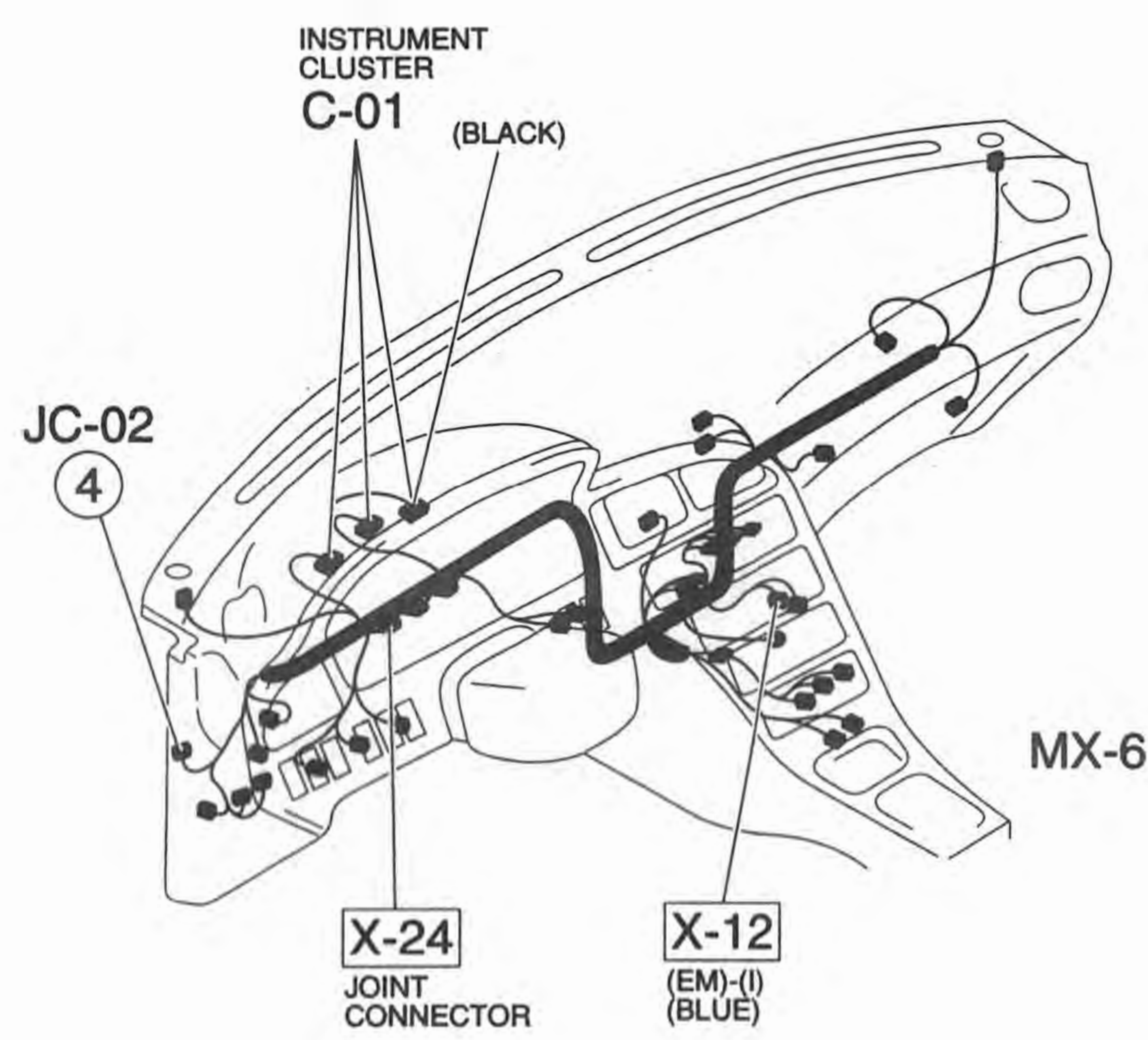
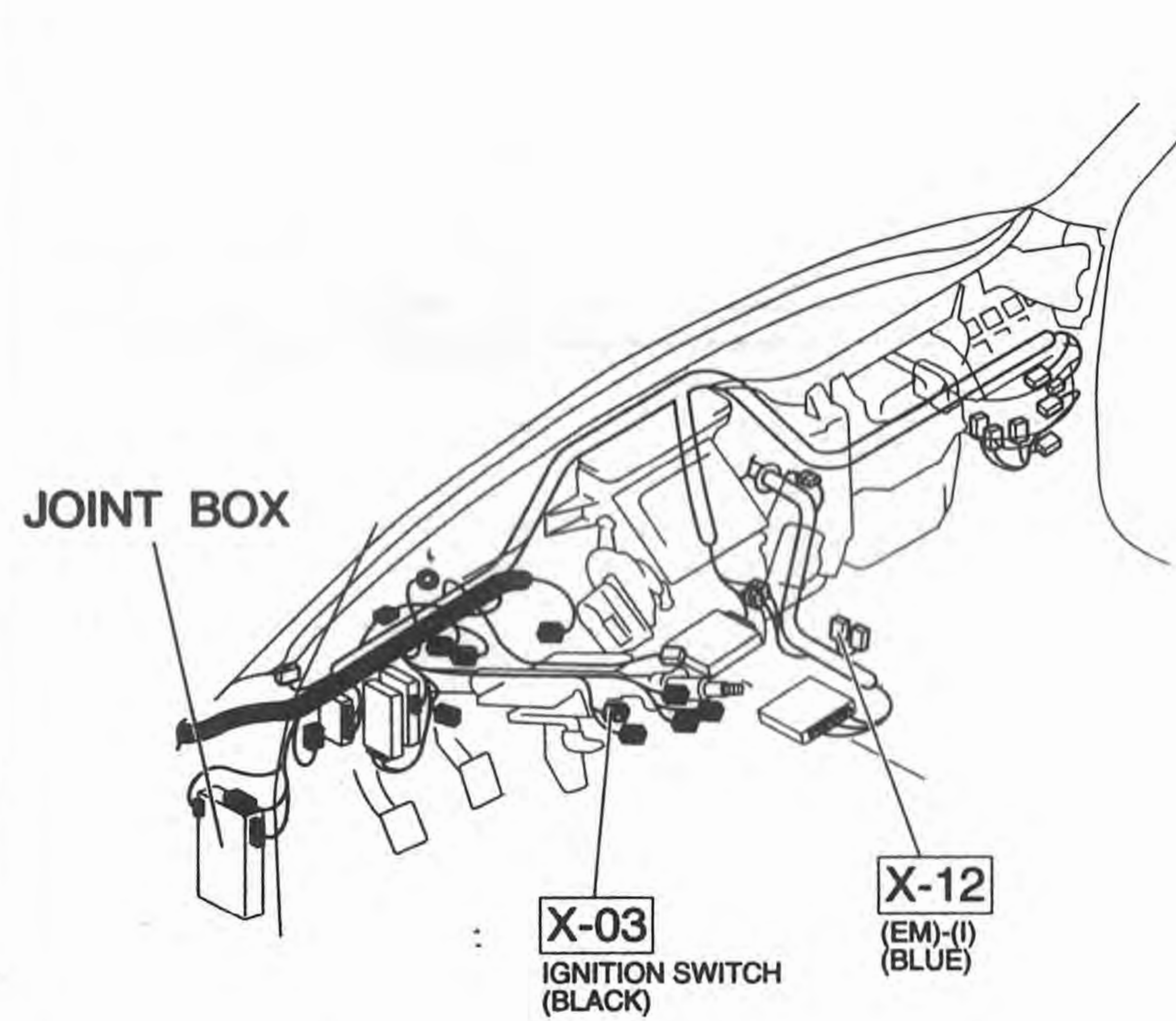
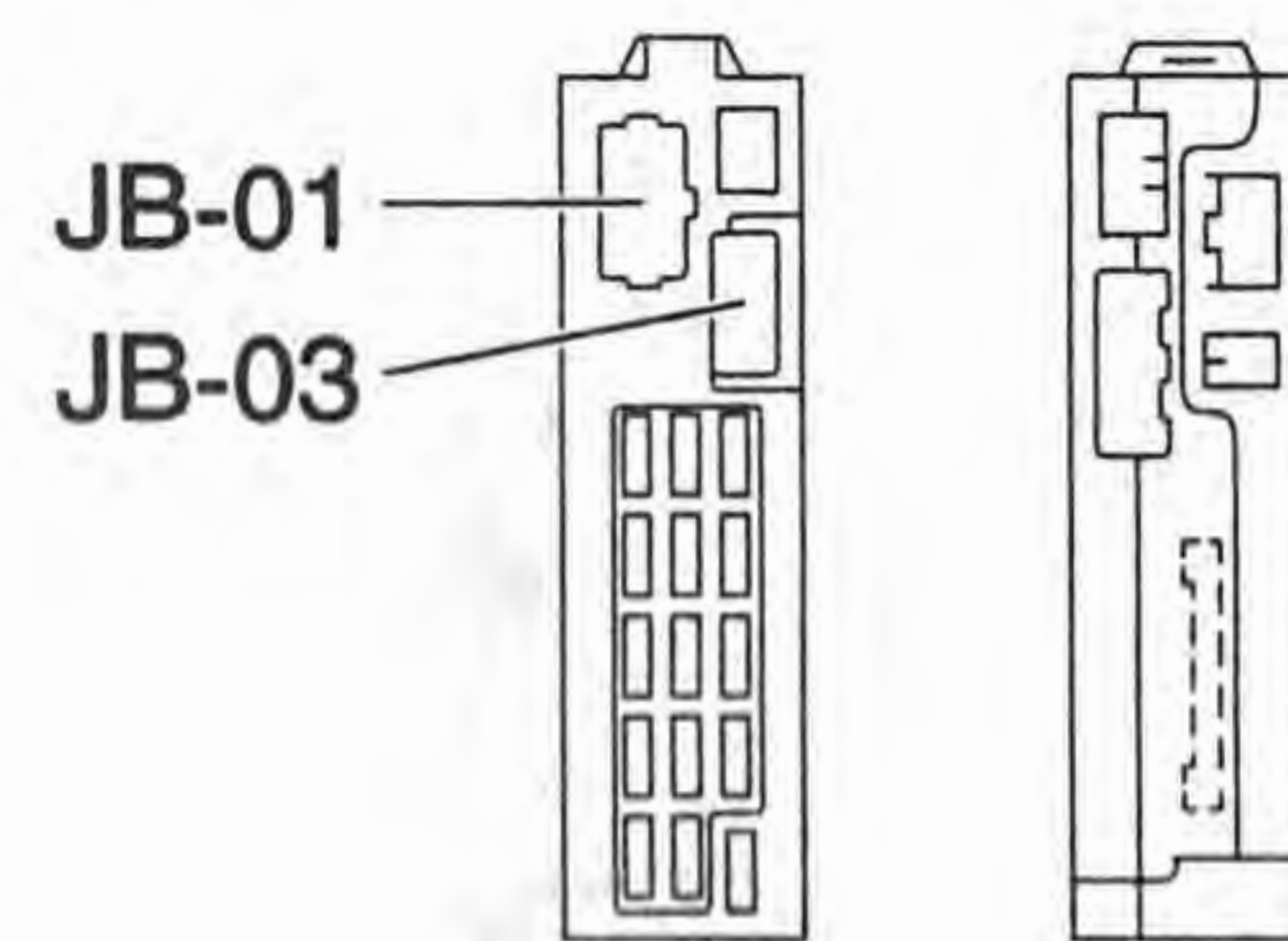

C-b

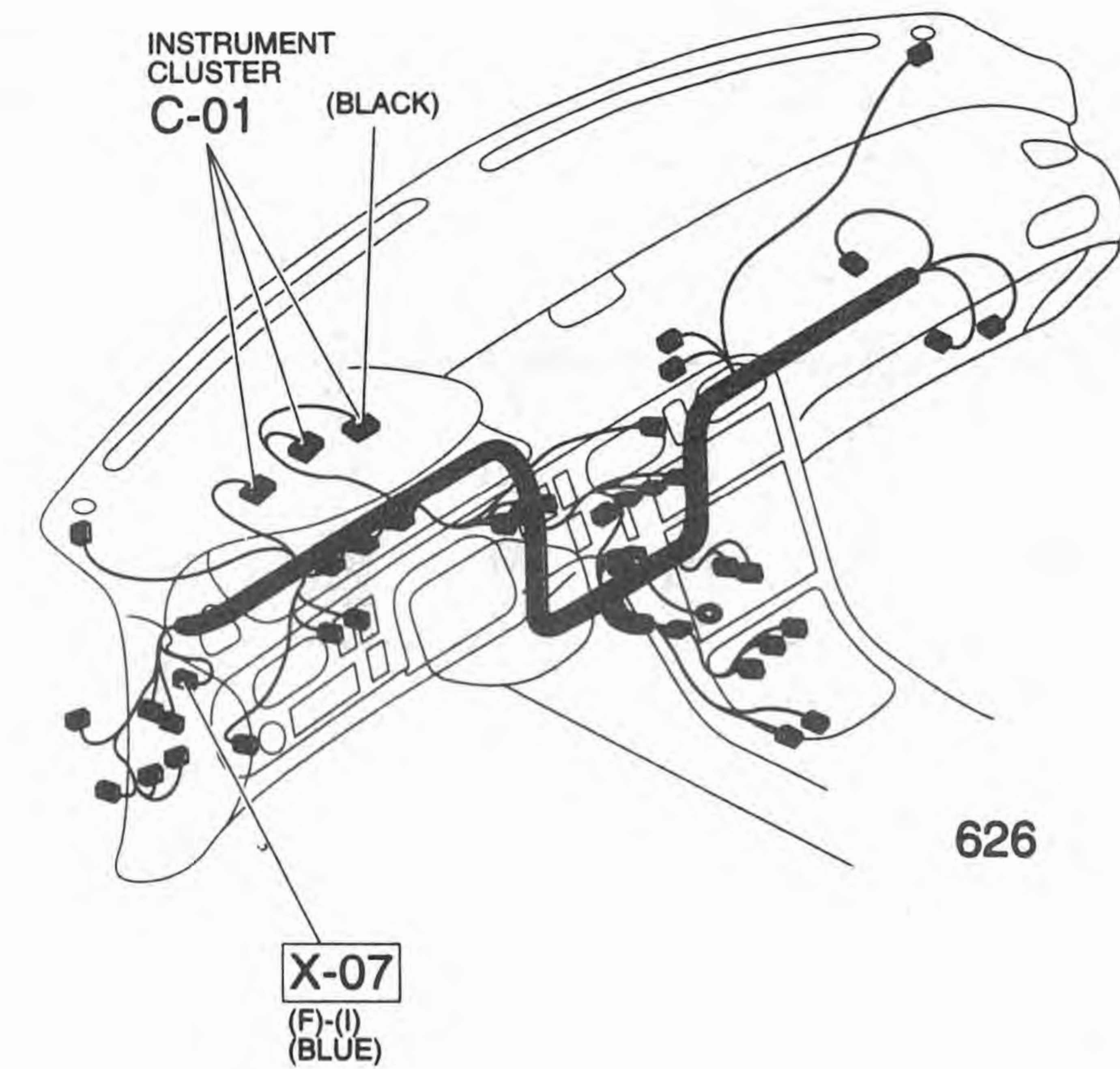
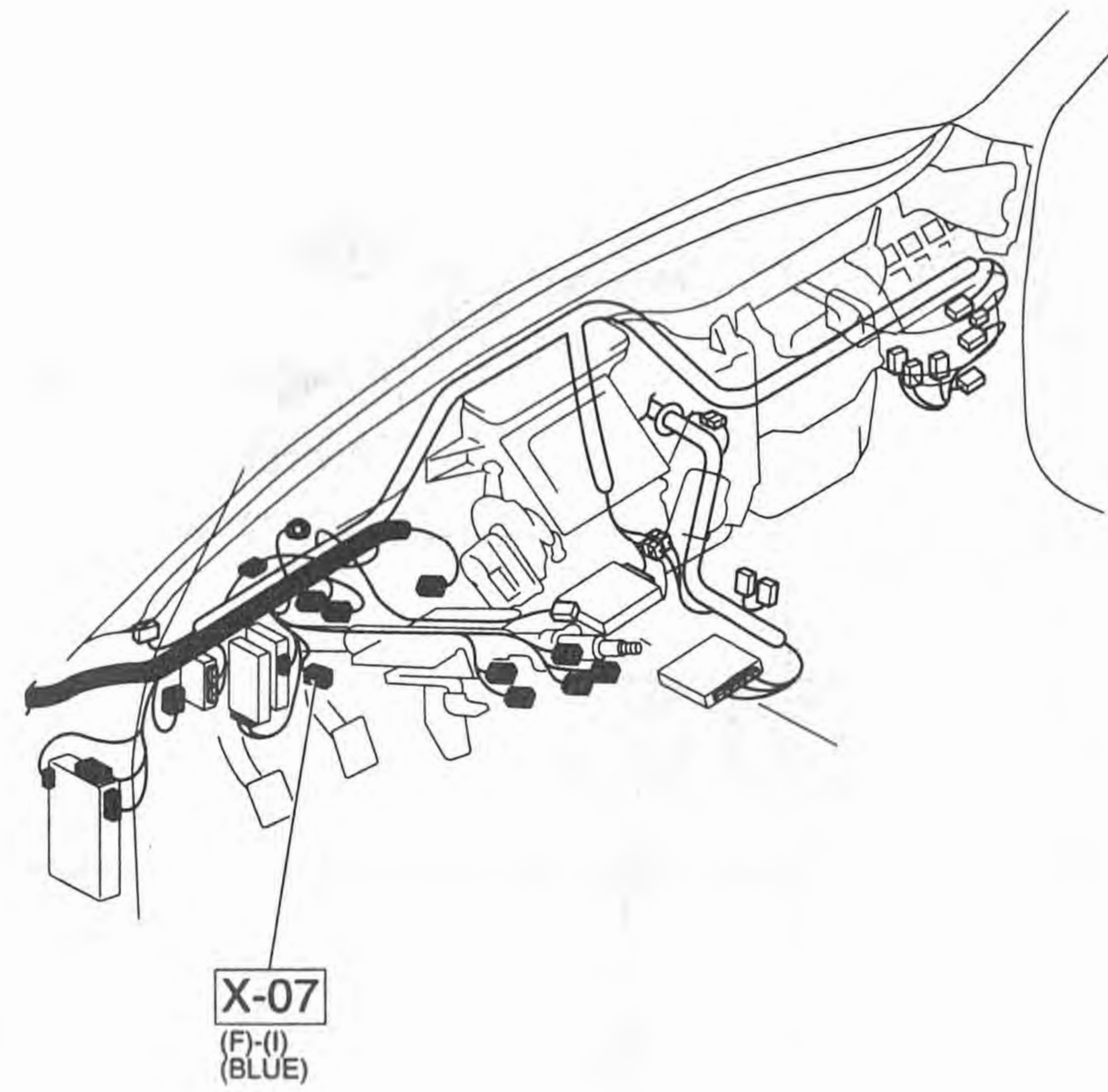
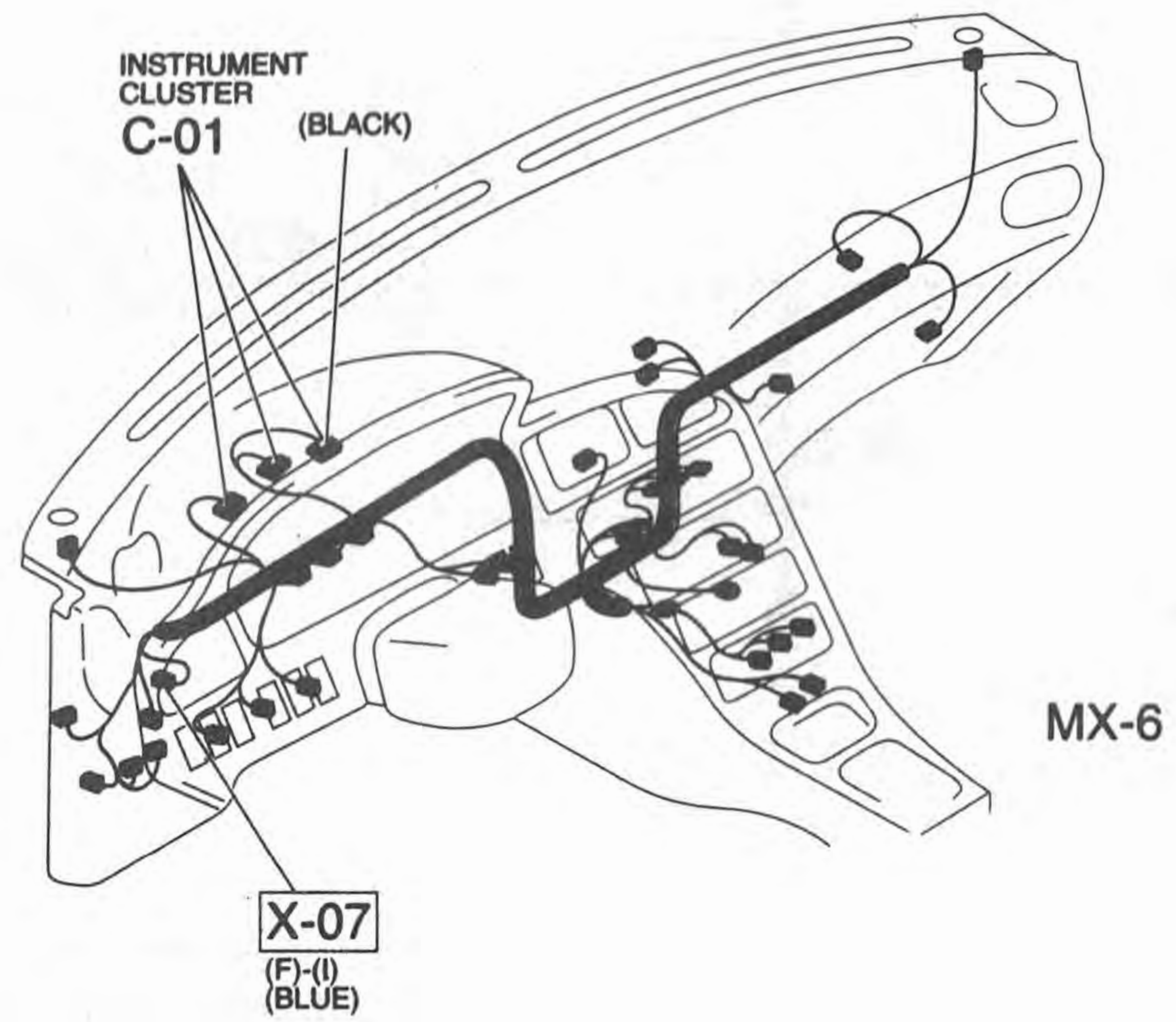
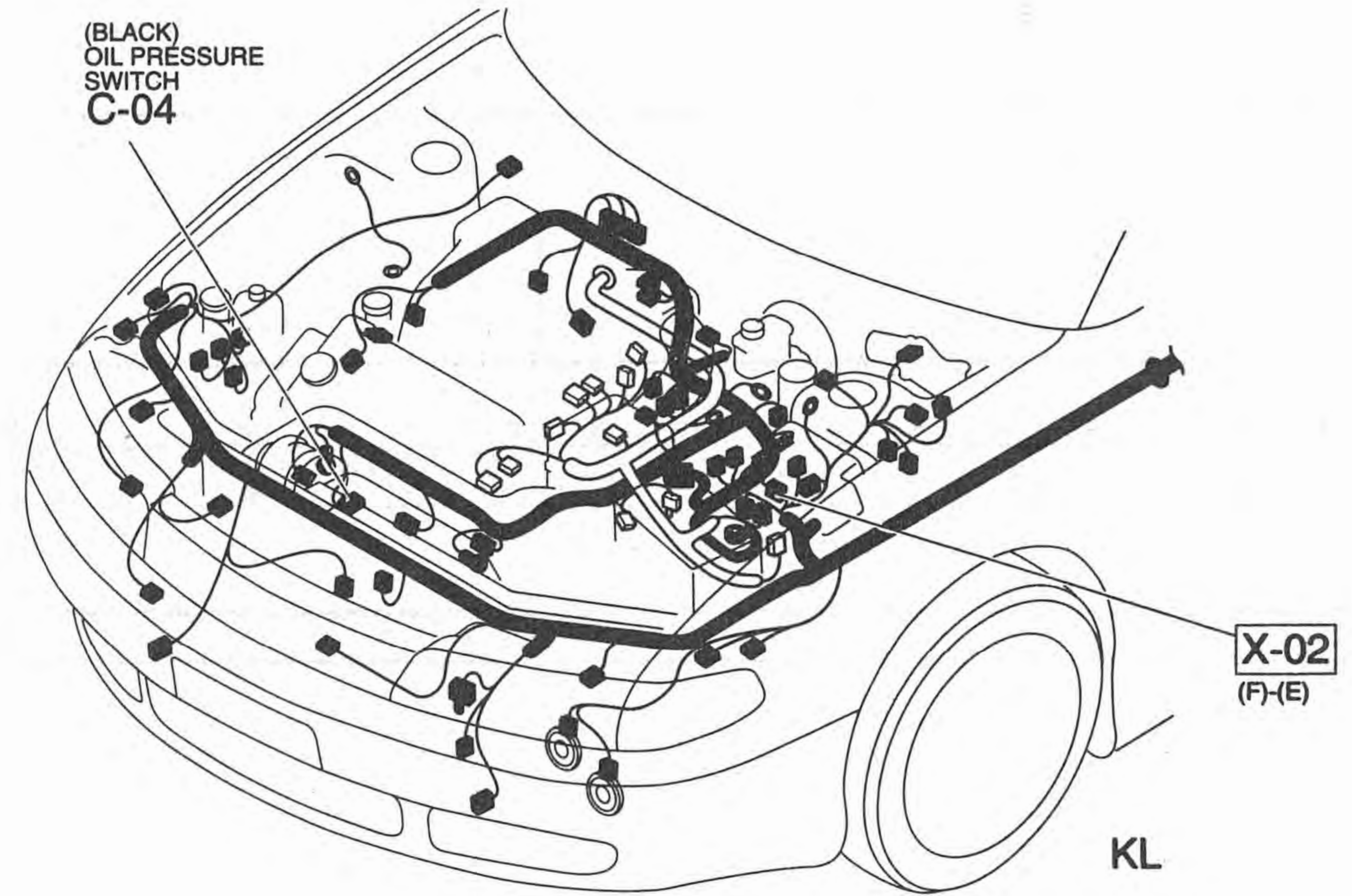
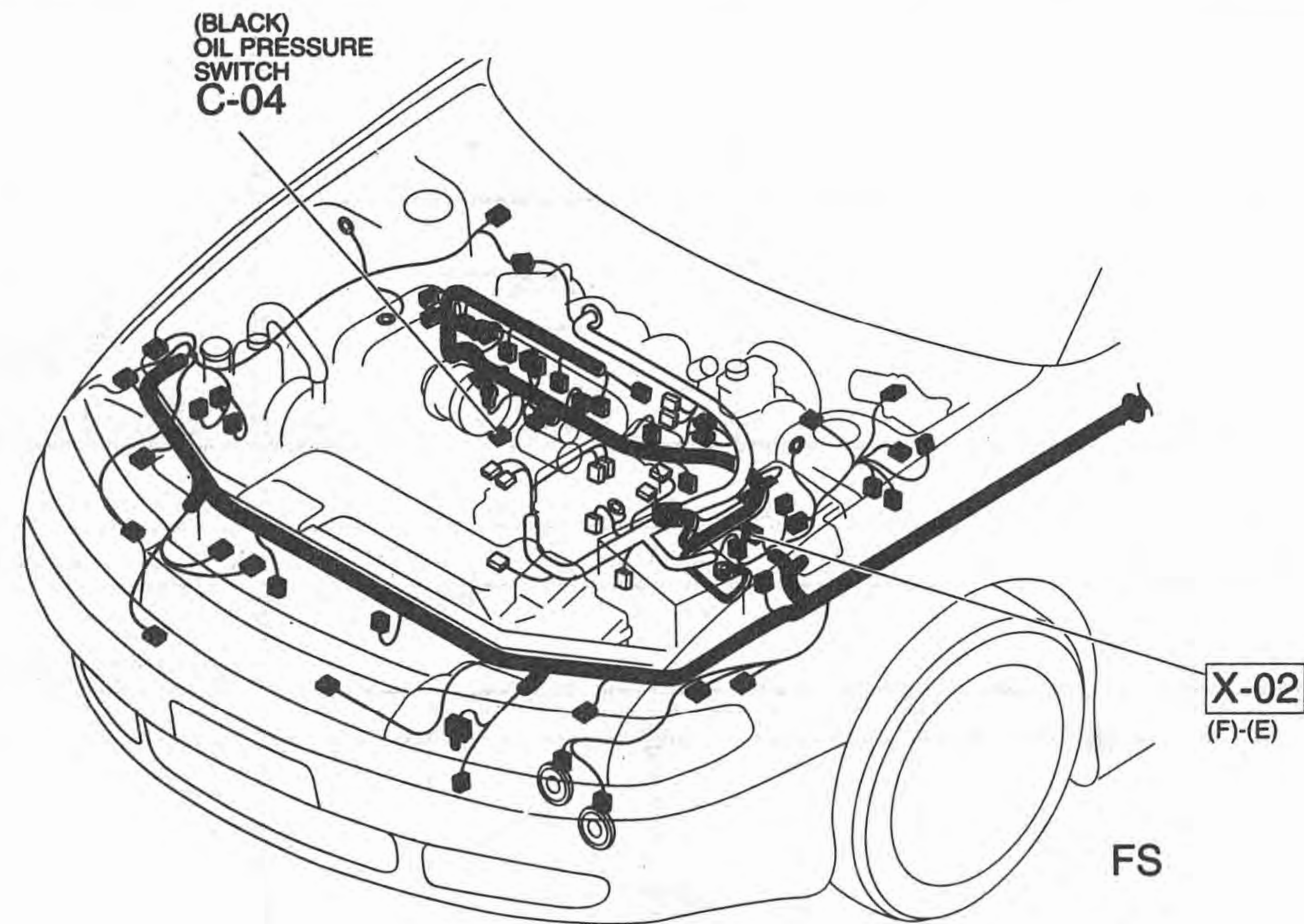

C-c INSTRUMENT CLUSTER

0 ... ATX
* ... CANADA

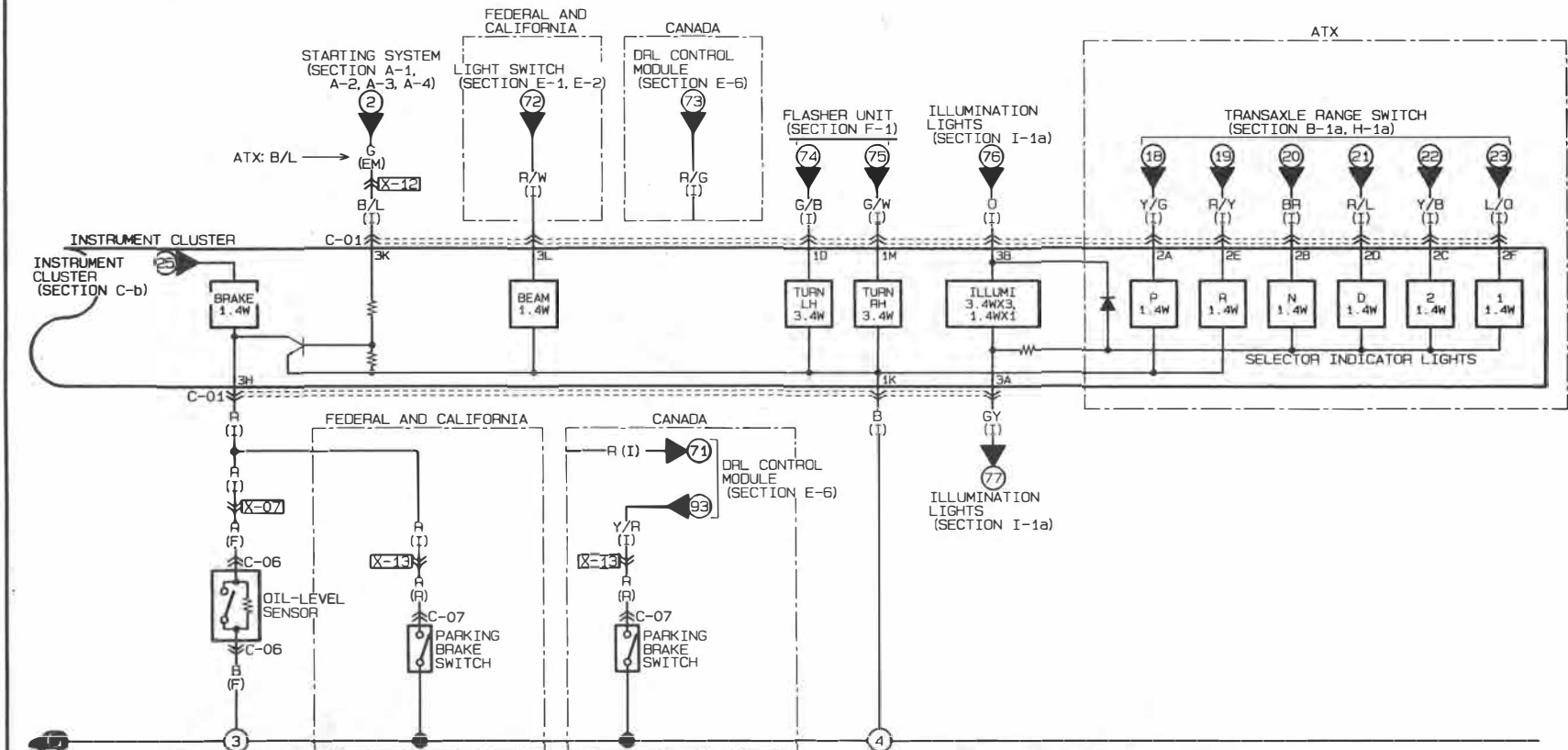

C-01 INSTRUMENT CLUSTER (I)

W (BR/Y)	G/W	B	W	G/R	G	GY/L	Y	G/B	B/R	R/B	L	L/R	LG	L/B	W/R	L/Y	B/Y	L/O	R/Y	R/L	Y/B	BR	Y/G	R/W	B/L	Y/R	R	W/B	R/G	BR/B	R/W	O	GY						
1N	1M	1L	1K	1J	1I	1H	1G	1F	1E	1D	1C	1B	1A	2N	2M	2L	2K	2J	2I	2H	2G	2F	2E	2D	2C	2B	2A	3L	3K	3J	3I	3H	3G	3F	3E	3D	3C	3B	3A

C-06 OIL-LEVEL SENSOR (F)



C-07 PARKING BRAKE SWITCH (R)



C-c

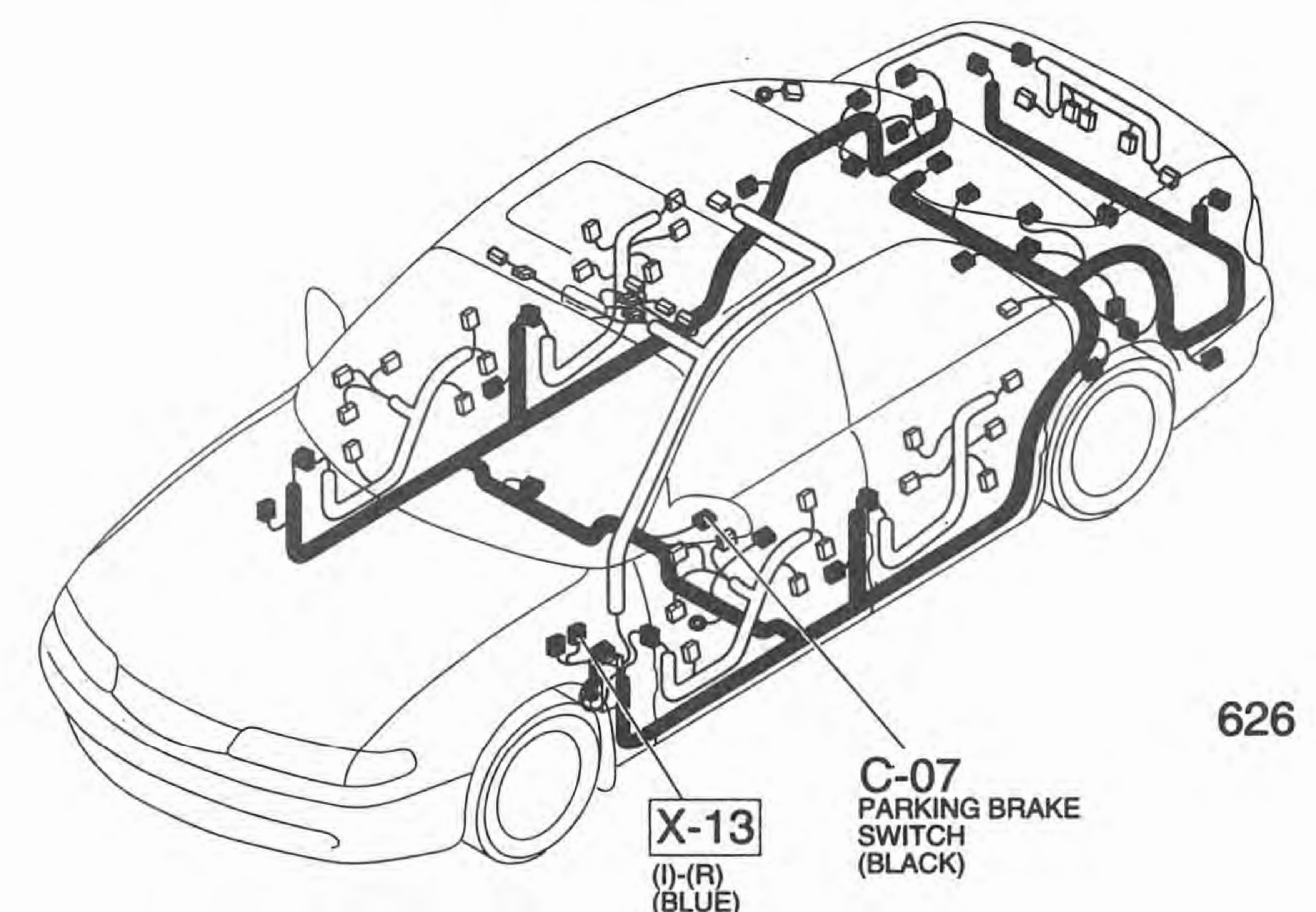
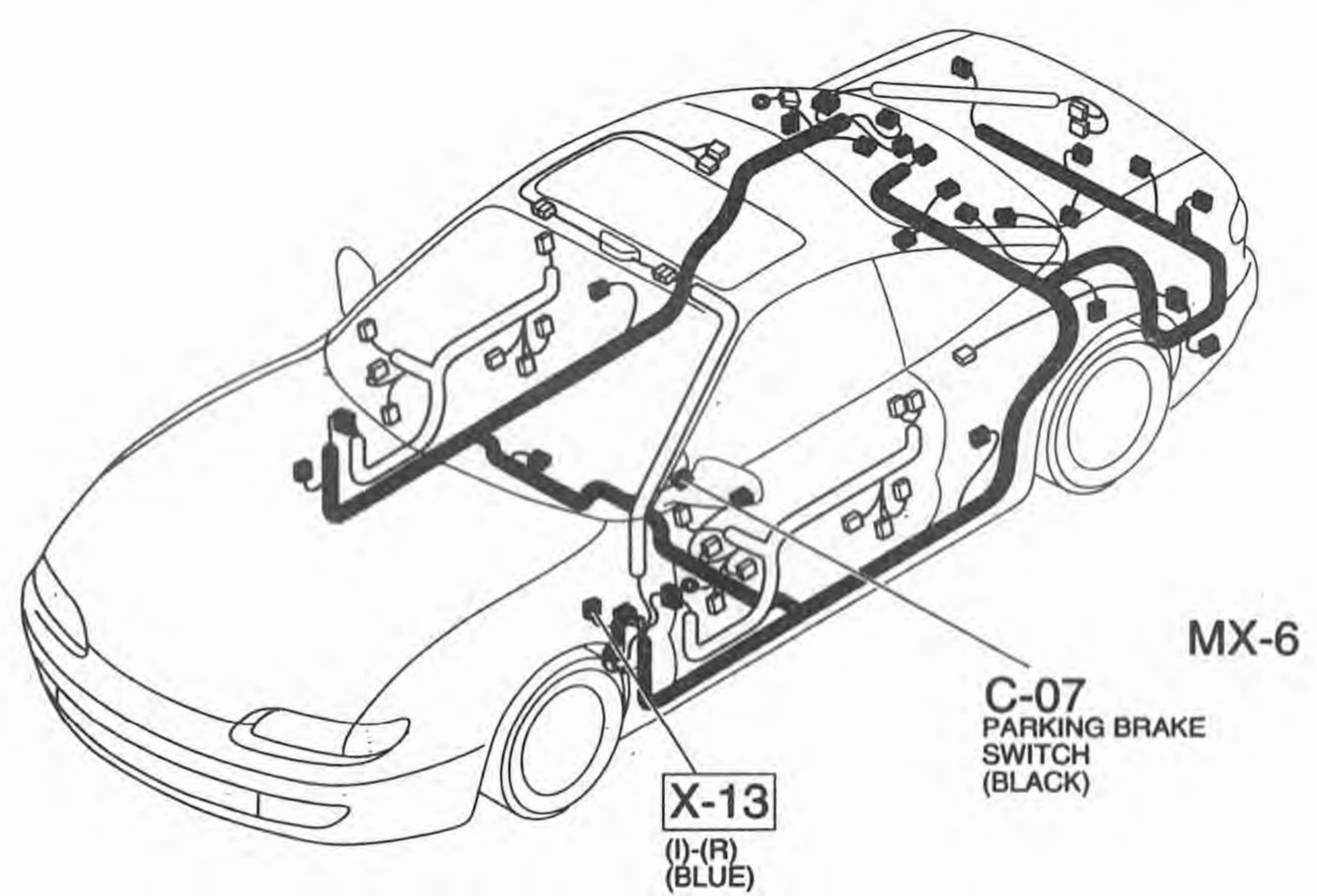
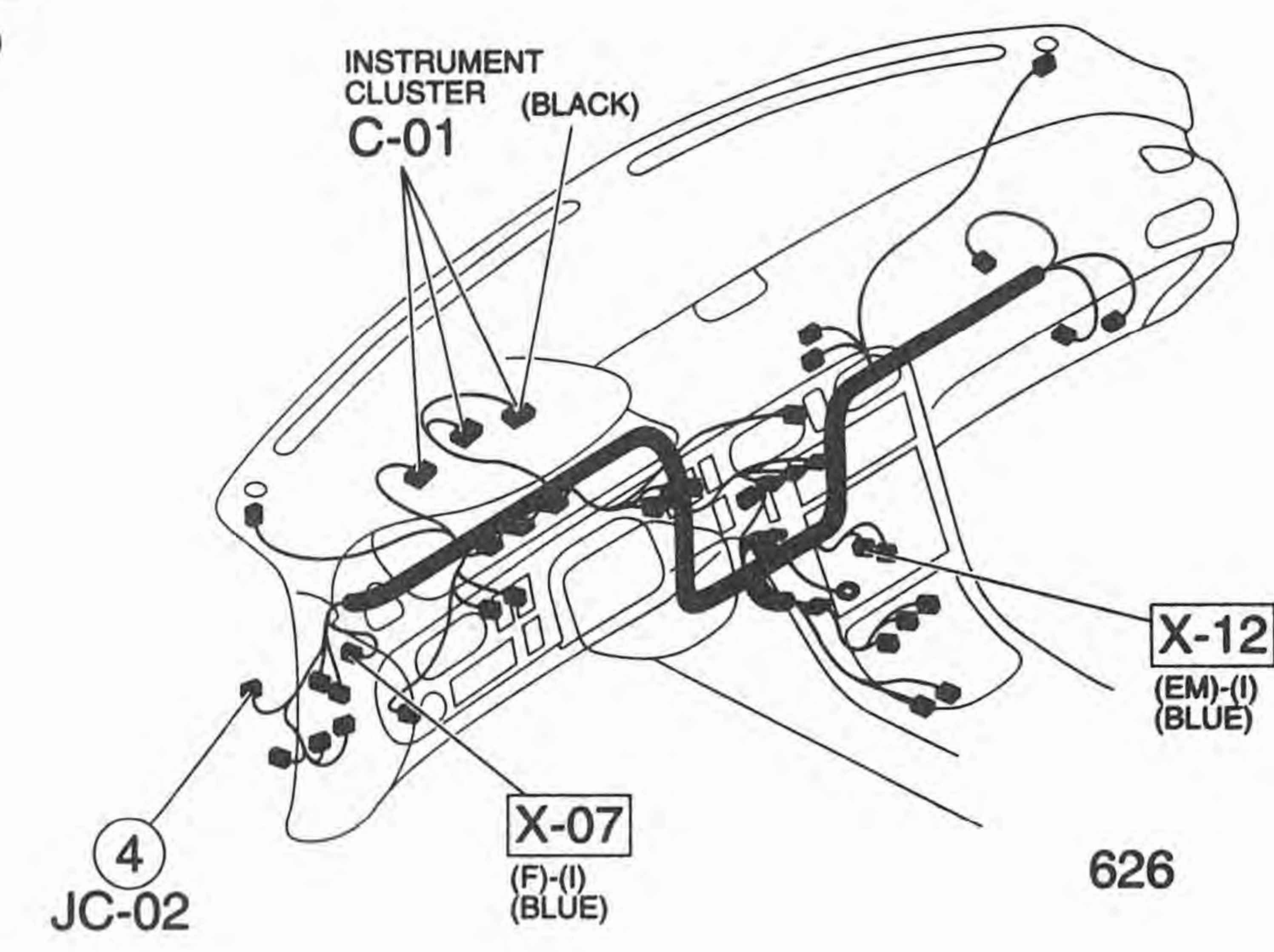
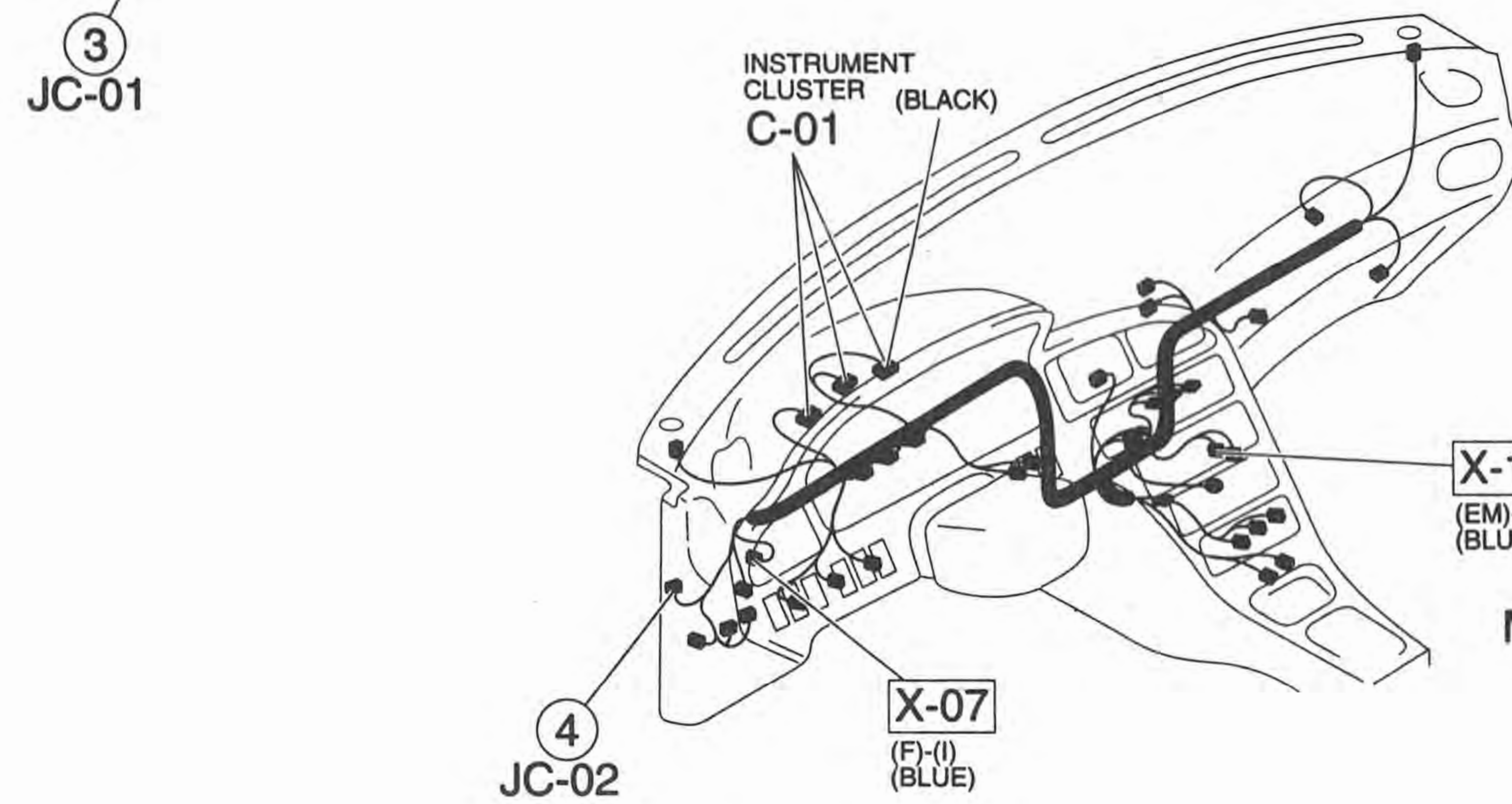
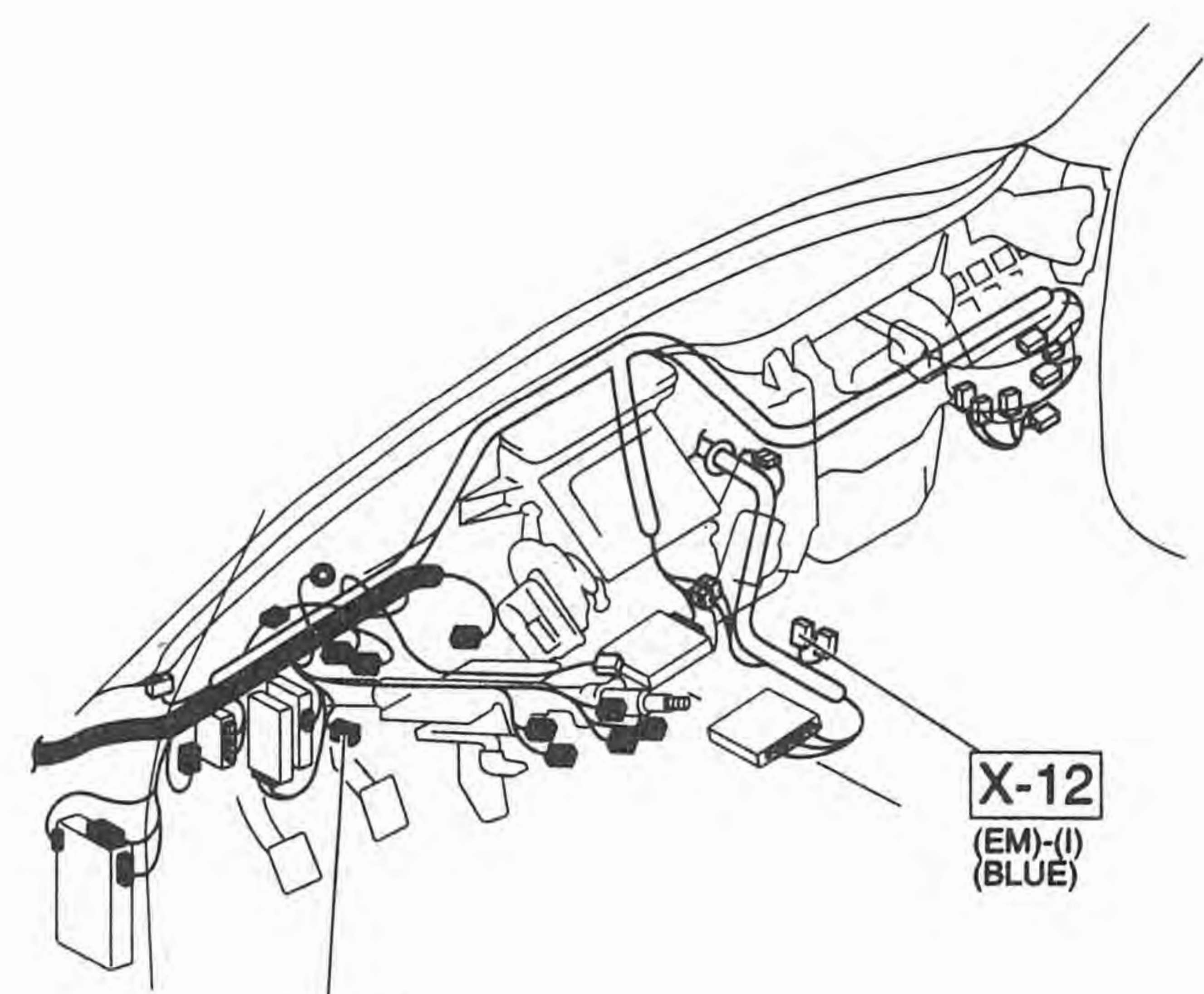
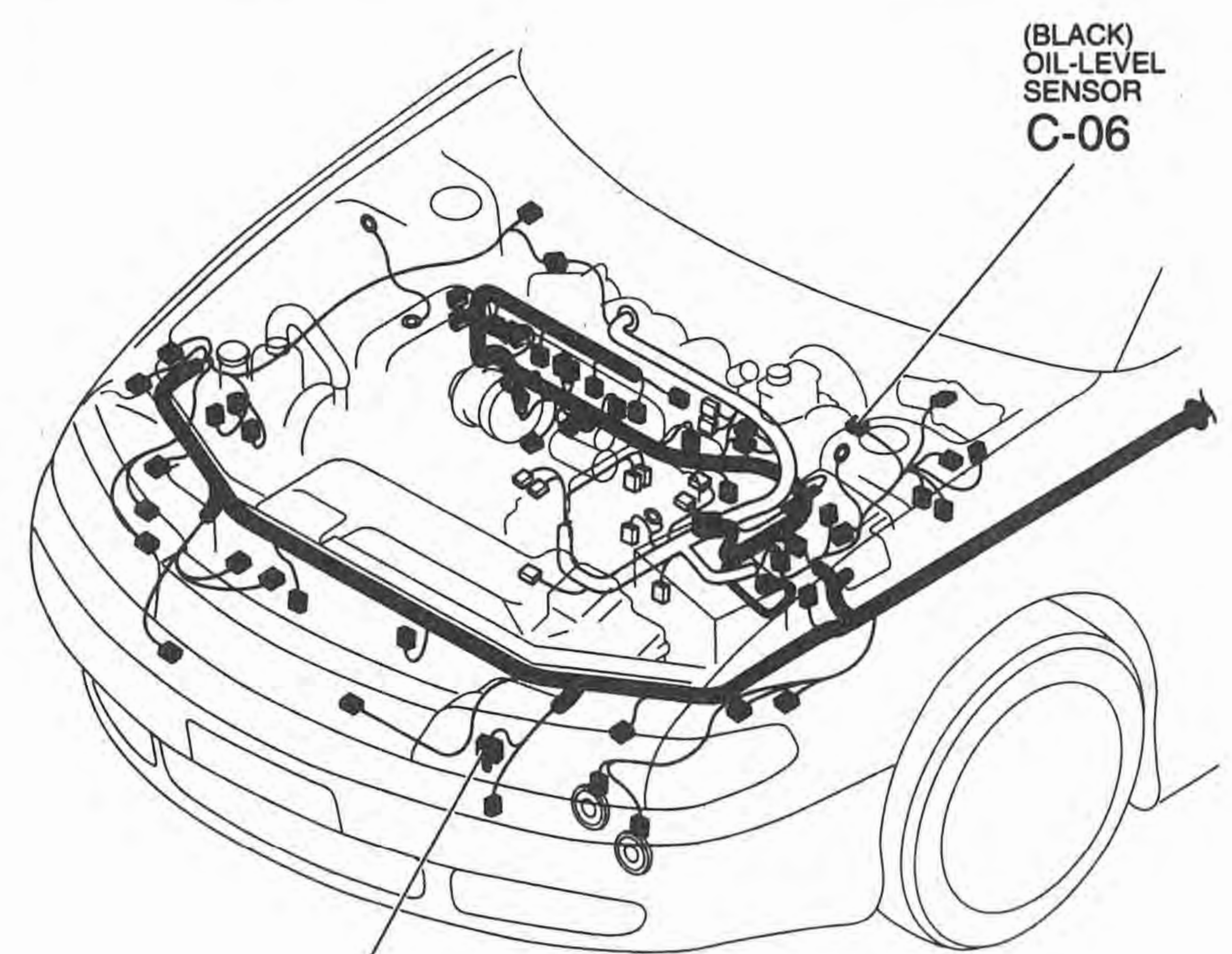

Z WIRING DIAGRAM

D ■ WINDSHIELD WIPER AND WASHER

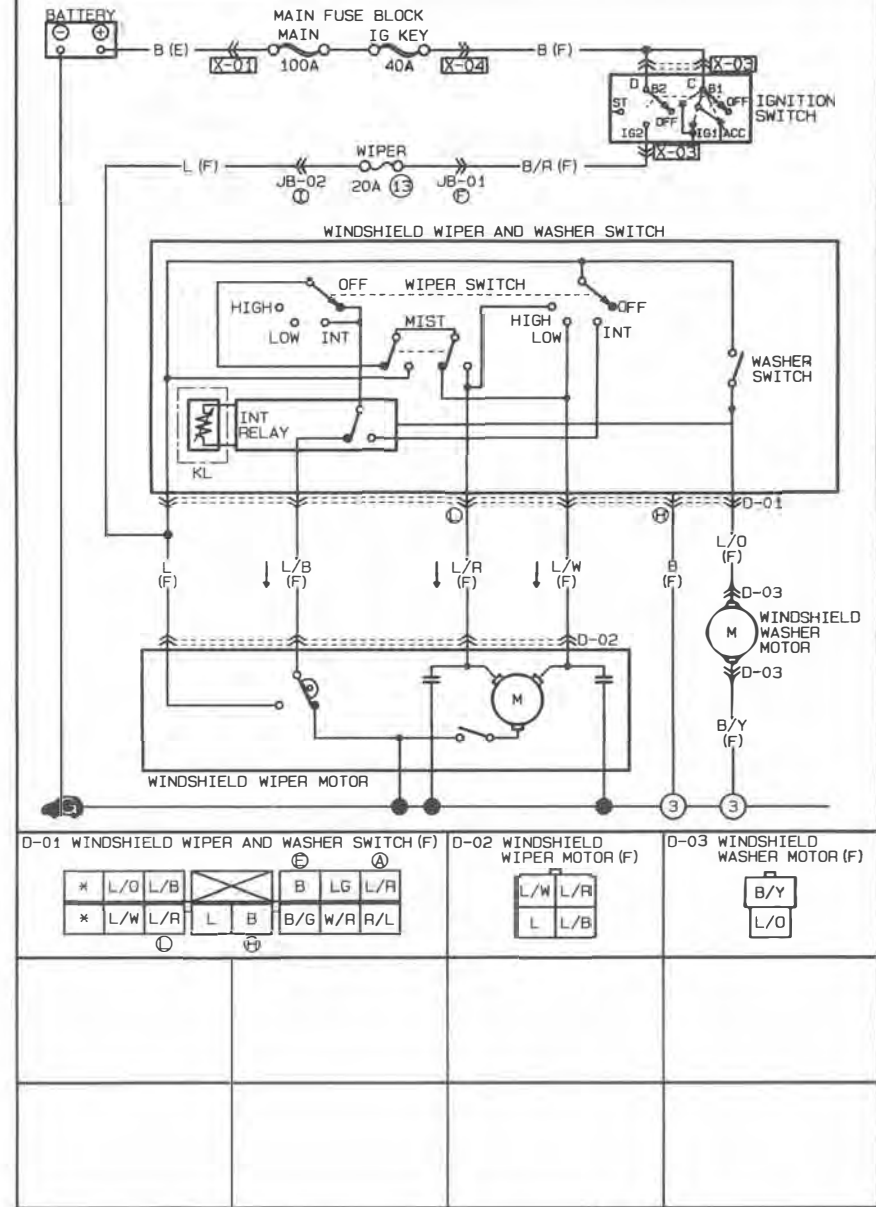

D

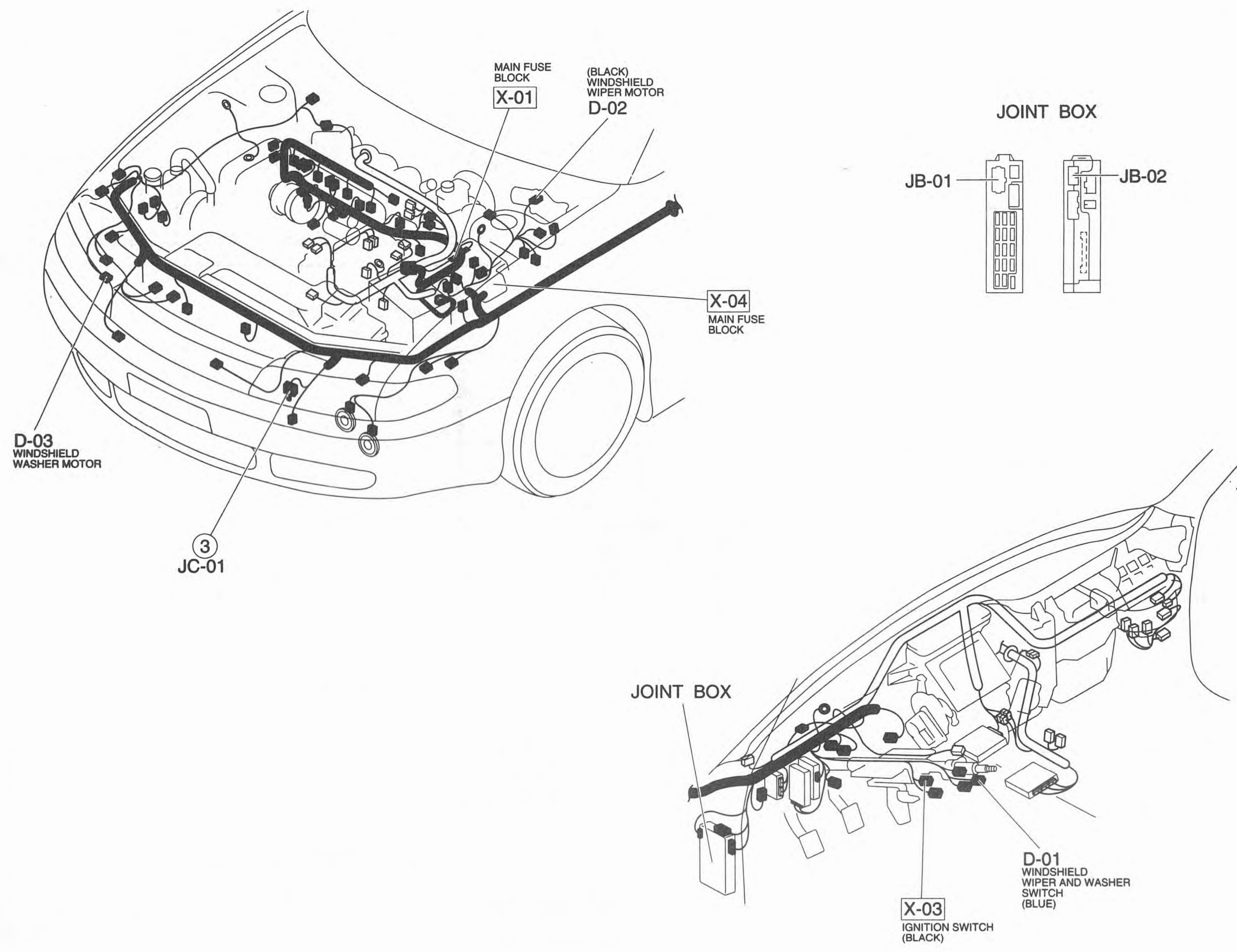

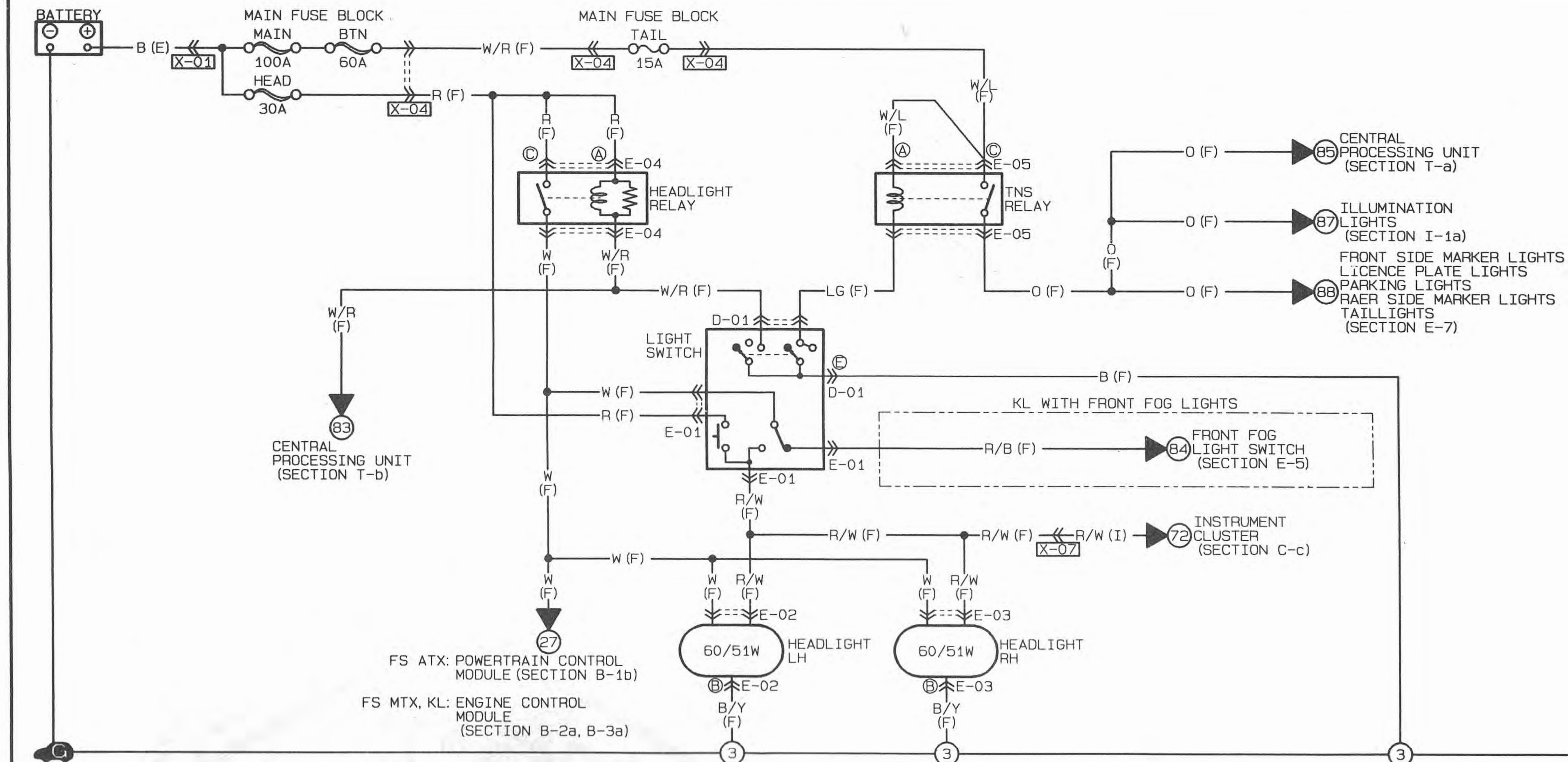

E-01 LIGHT SWITCH (F)	E-02 HEADLIGHT LH (F)	E-03 HEADLIGHT RH (F)	E-04 HEADLIGHT RELAY (F)	E-05 TNS RELAY (F)	D-01 LIGHT SWITCH (F)

E-1

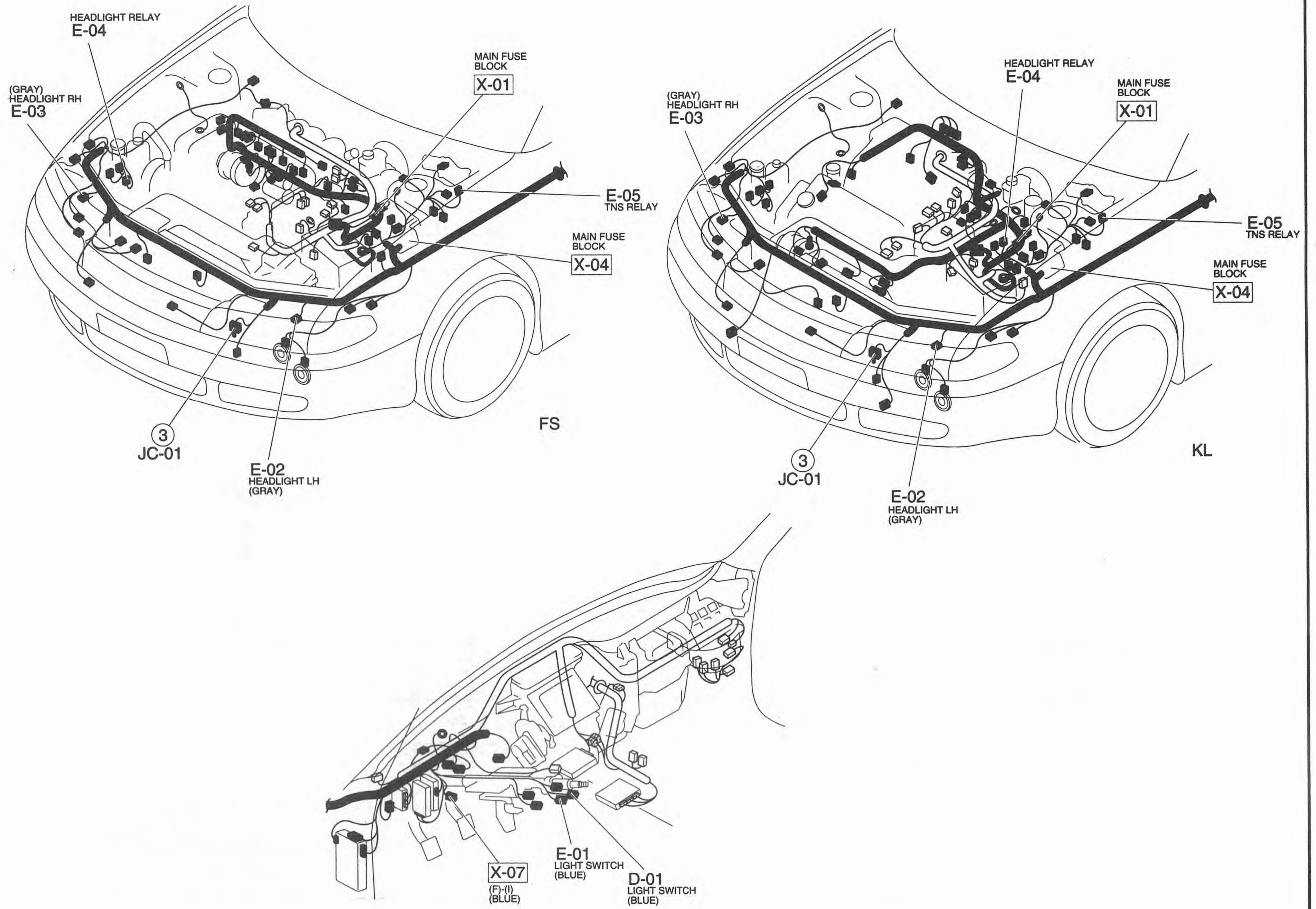

E-2 FEDERAL AND CALIFORNIA MX-6 ■ HEADLIGHTS

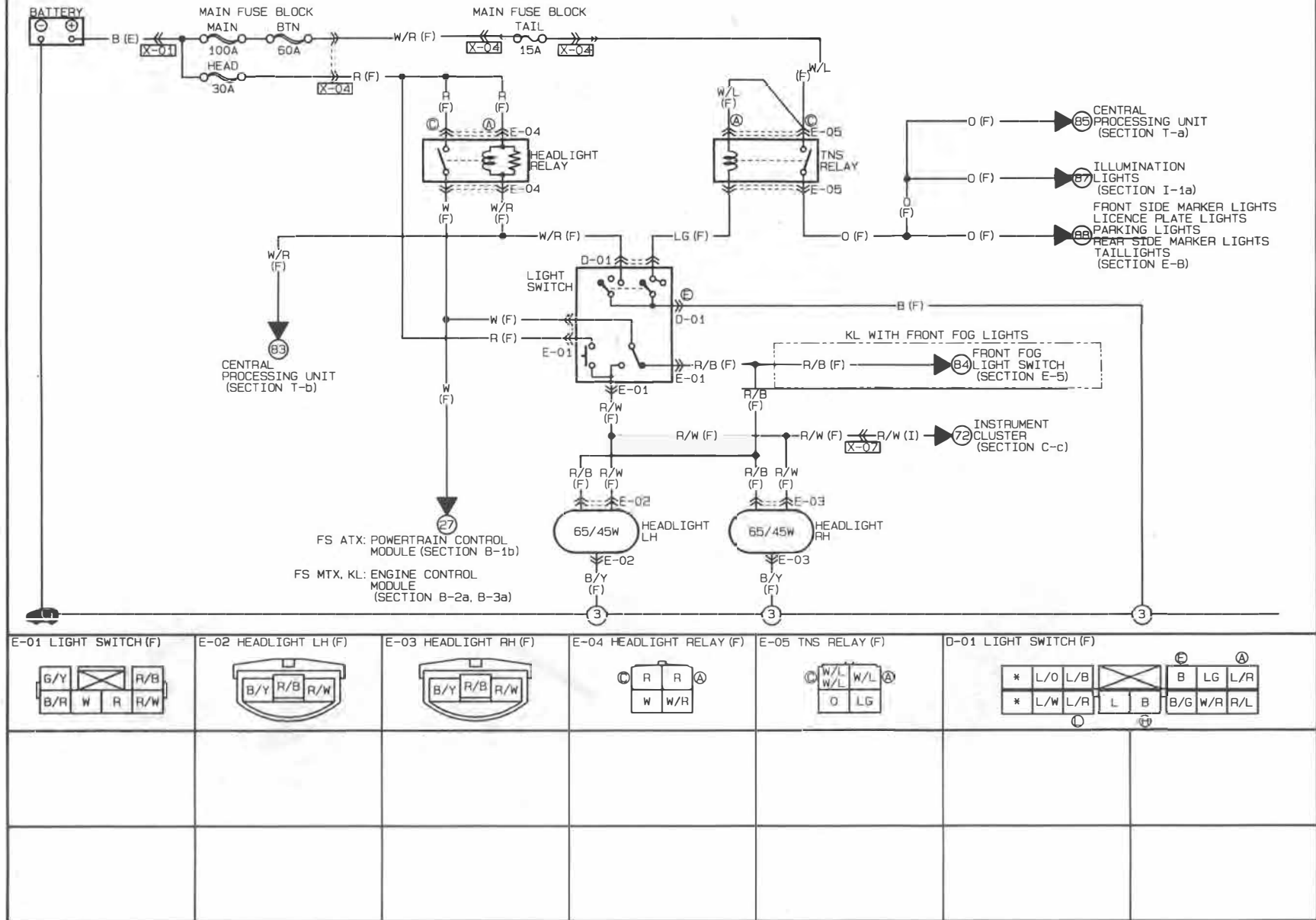

E-2

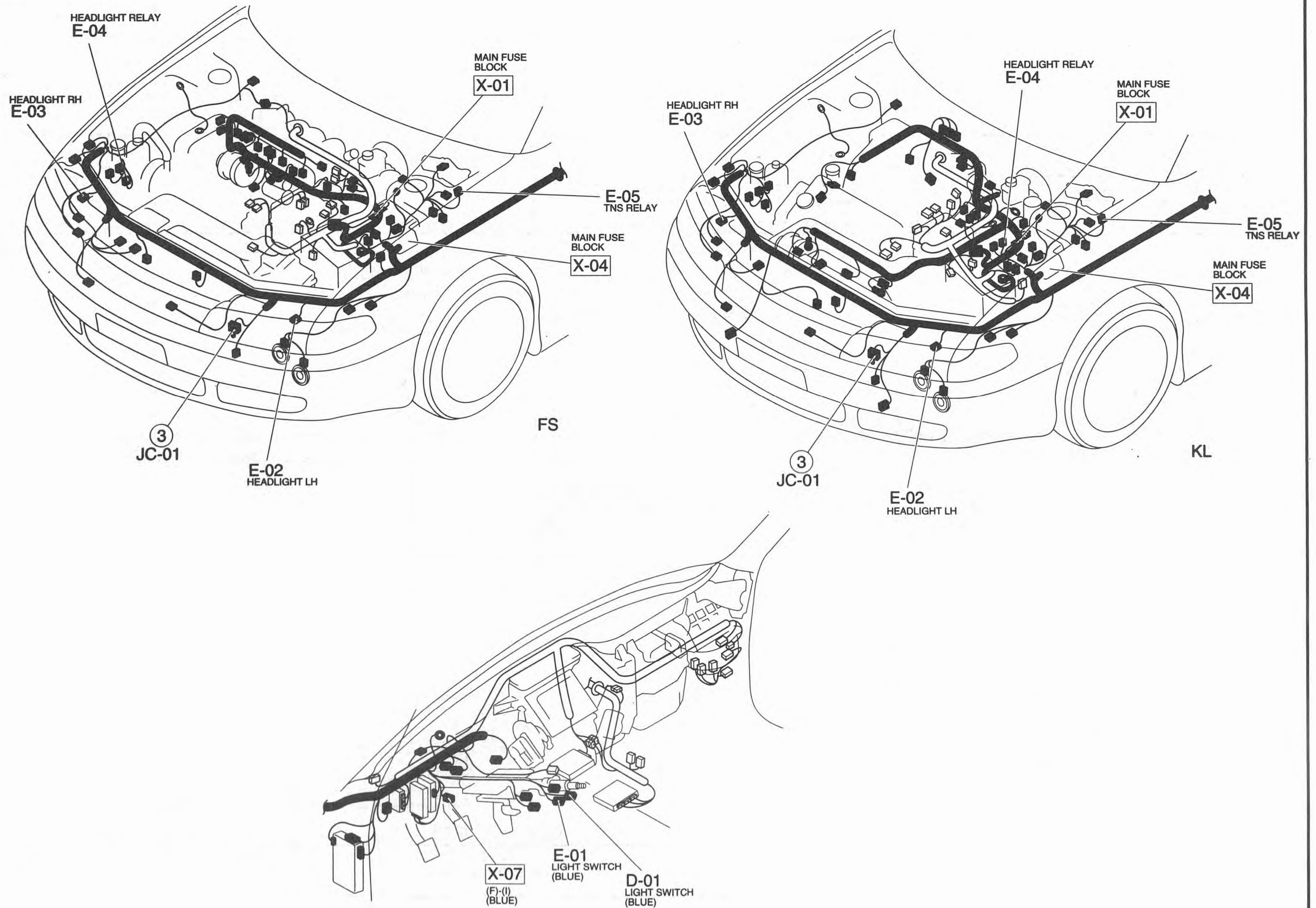

E-3 CANADA 626 HEADLIGHTS

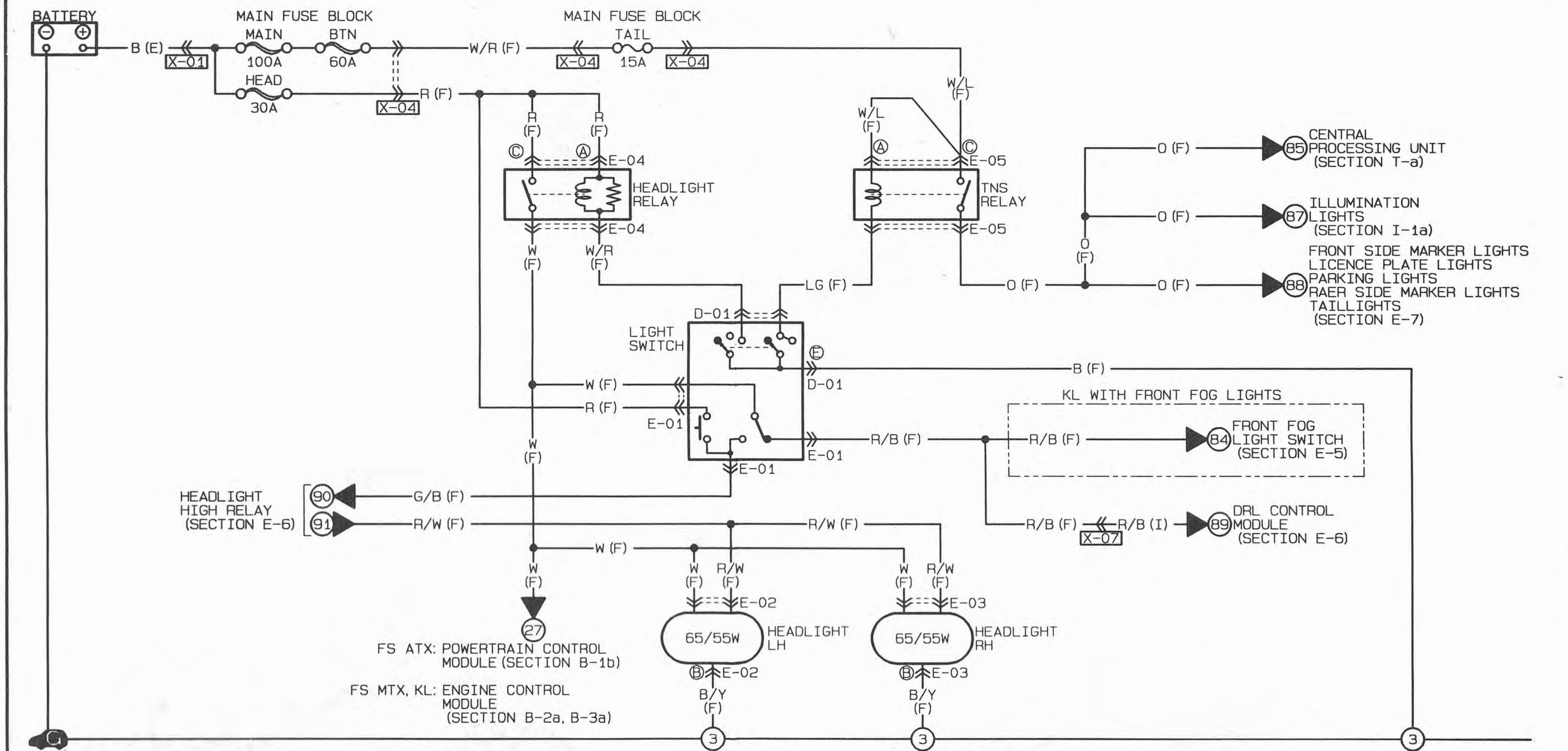

<p>E-01 LIGHT SWITCH (F)</p>	<p>E-02 HEADLIGHT LH (F)</p>	<p>E-03 HEADLIGHT RH (F)</p>	<p>E-04 HEADLIGHT RELAY (F)</p>	<p>E-05 TNS RELAY (F)</p>	<p>D-01 LIGHT SWITCH (F)</p>
<p>FS ATX: POWERTRAIN CONTROL MODULE (SECTION B-1b)</p> <p>FS MTX, KL: ENGINE CONTROL MODULE (SECTION B-2a, B-3a)</p>					

E-3

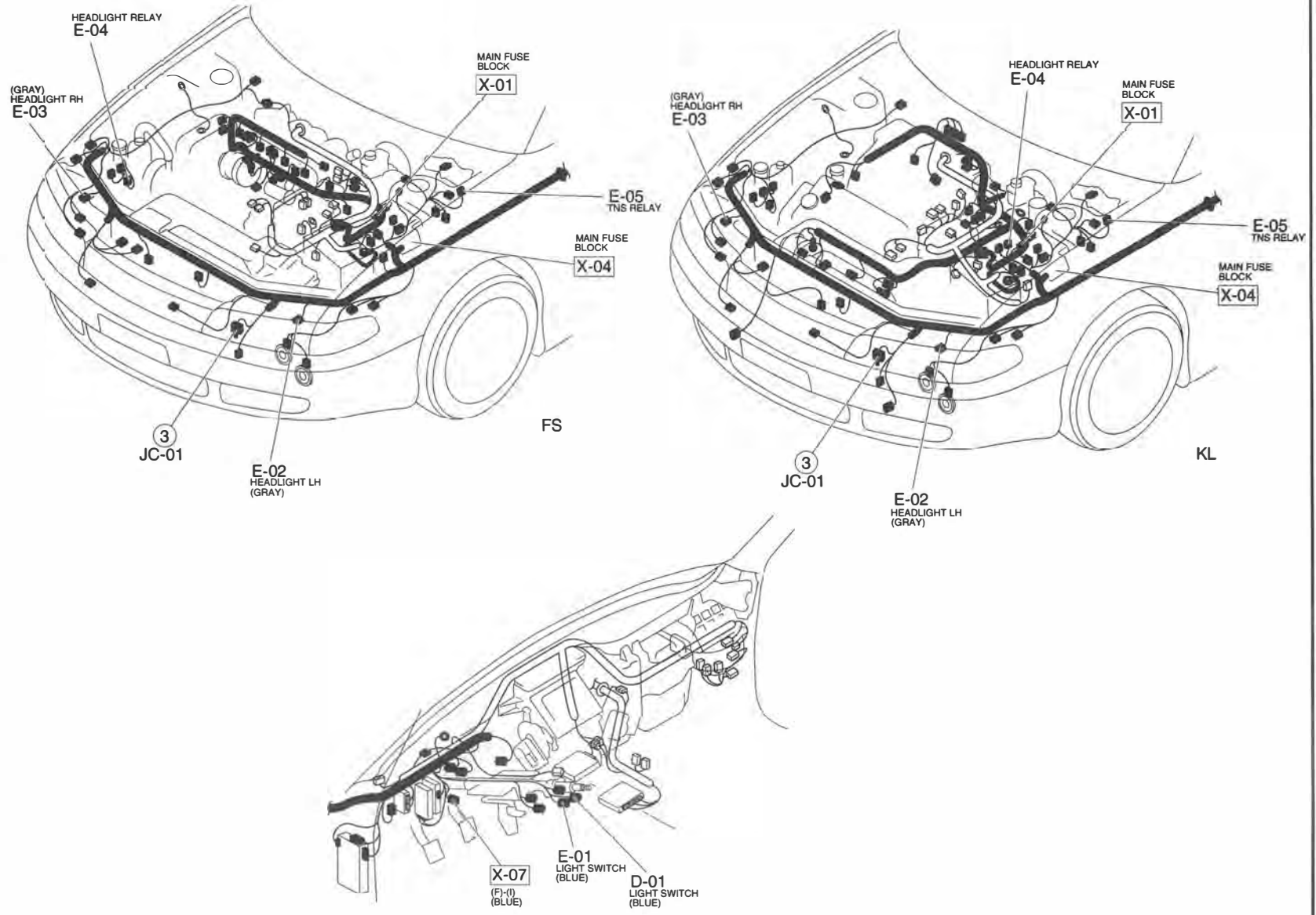

E-4 CANADA MX-6 ■ HEADLIGHTS

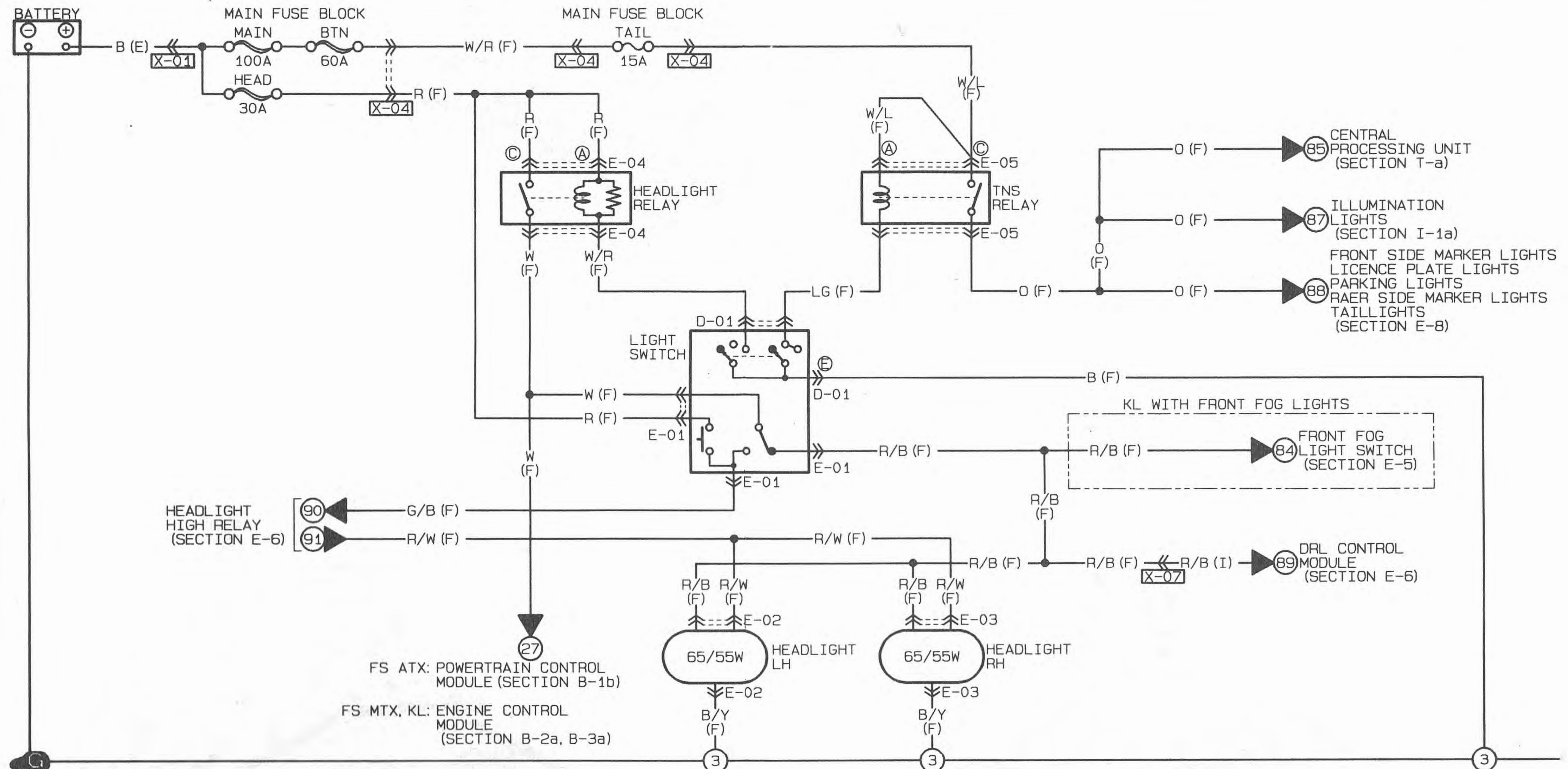

HEADLIGHT HIGH RELAY (SECTION E-6)
 90
 91

FS ATX: POWERTRAIN CONTROL MODULE (SECTION B-1b)
 FS MTX, KL: ENGINE CONTROL MODULE (SECTION B-2a, B-3a)

E-01 LIGHT SWITCH (F)

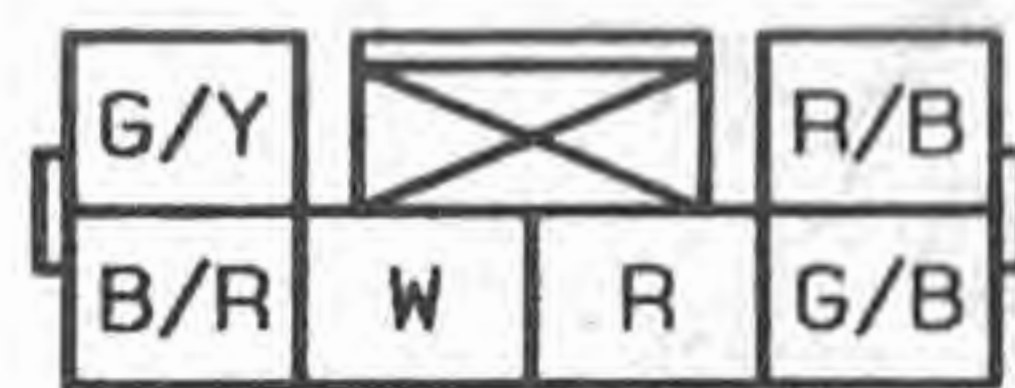

E-02 HEADLIGHT LH (F)

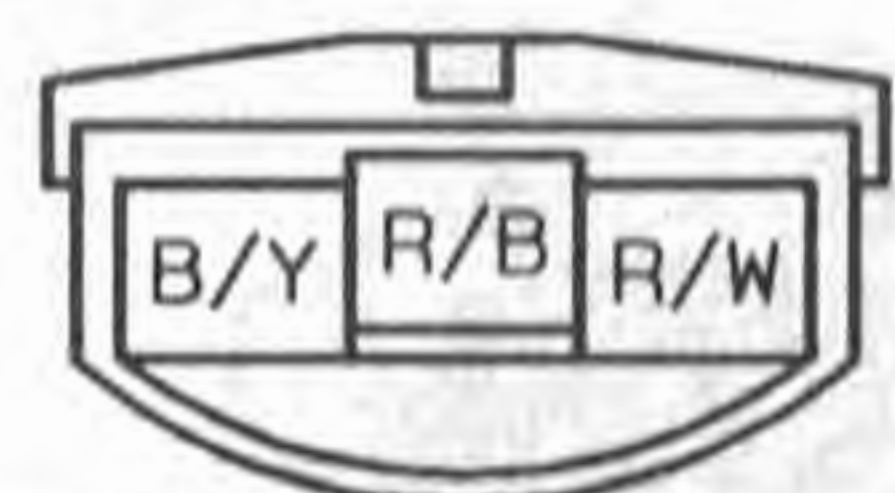

E-03 HEADLIGHT RH (F)

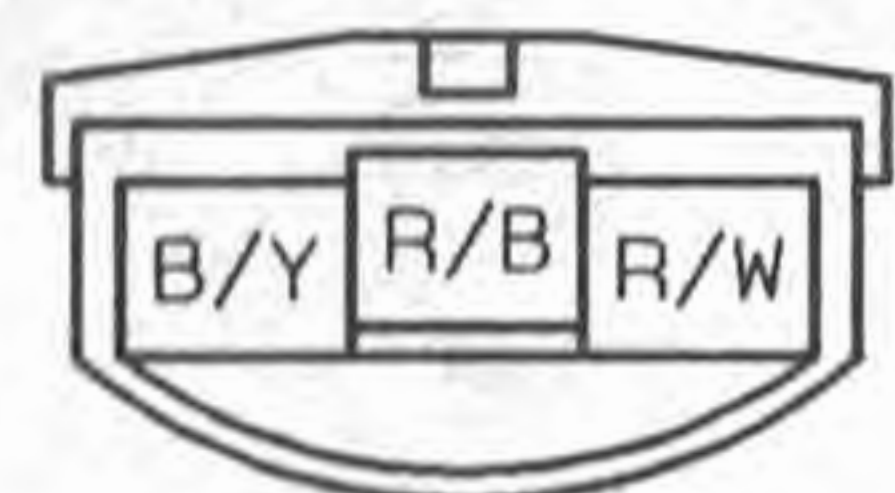

E-04 HEADLIGHT RELAY (F)

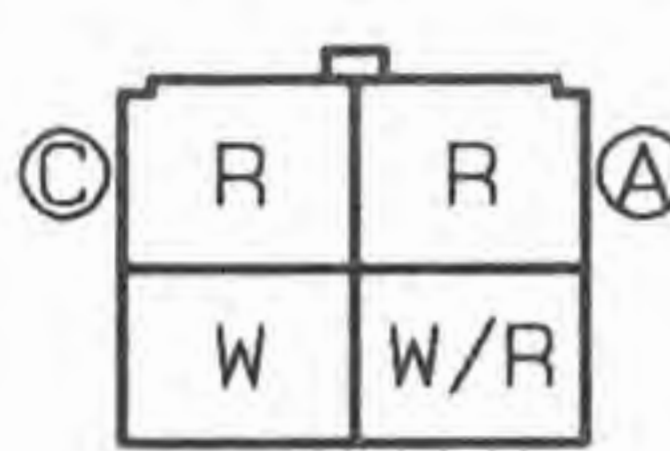

E-05 TNS RELAY (F)

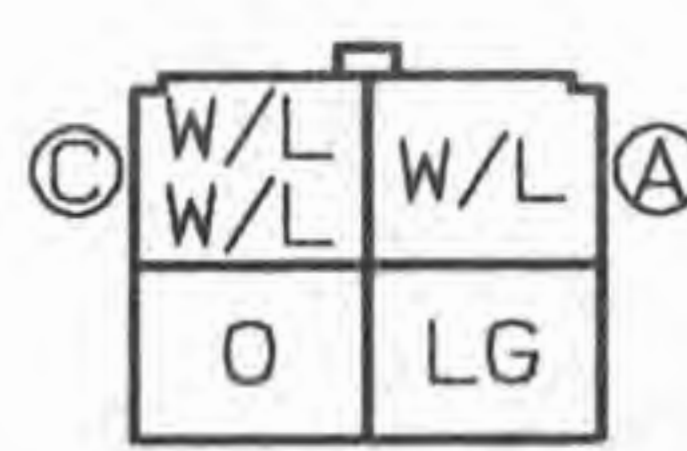

D-01 LIGHT SWITCH (F)

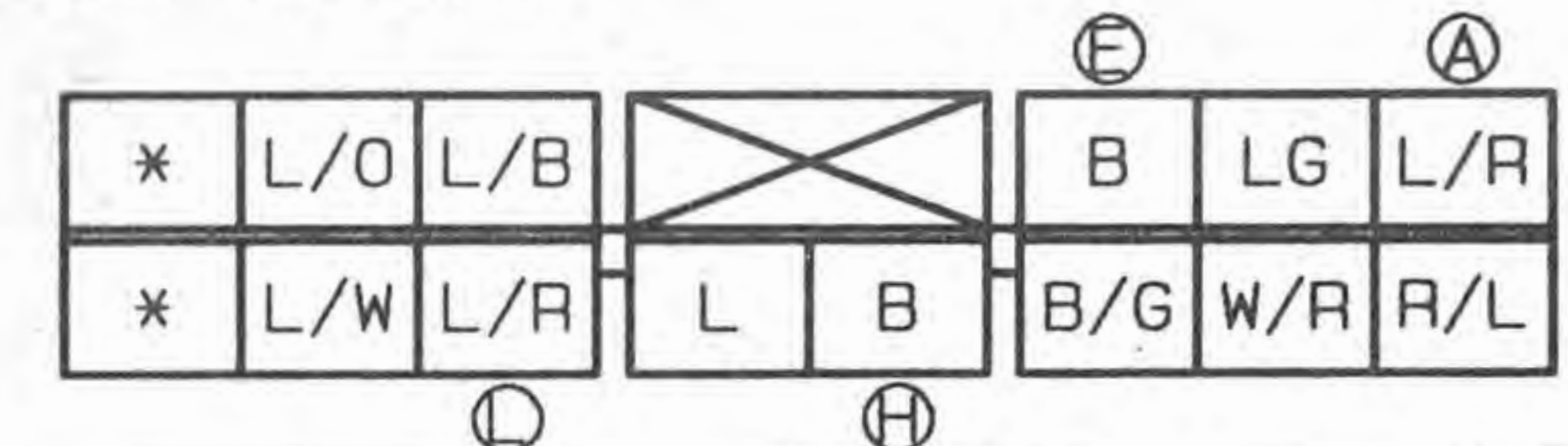

E-4

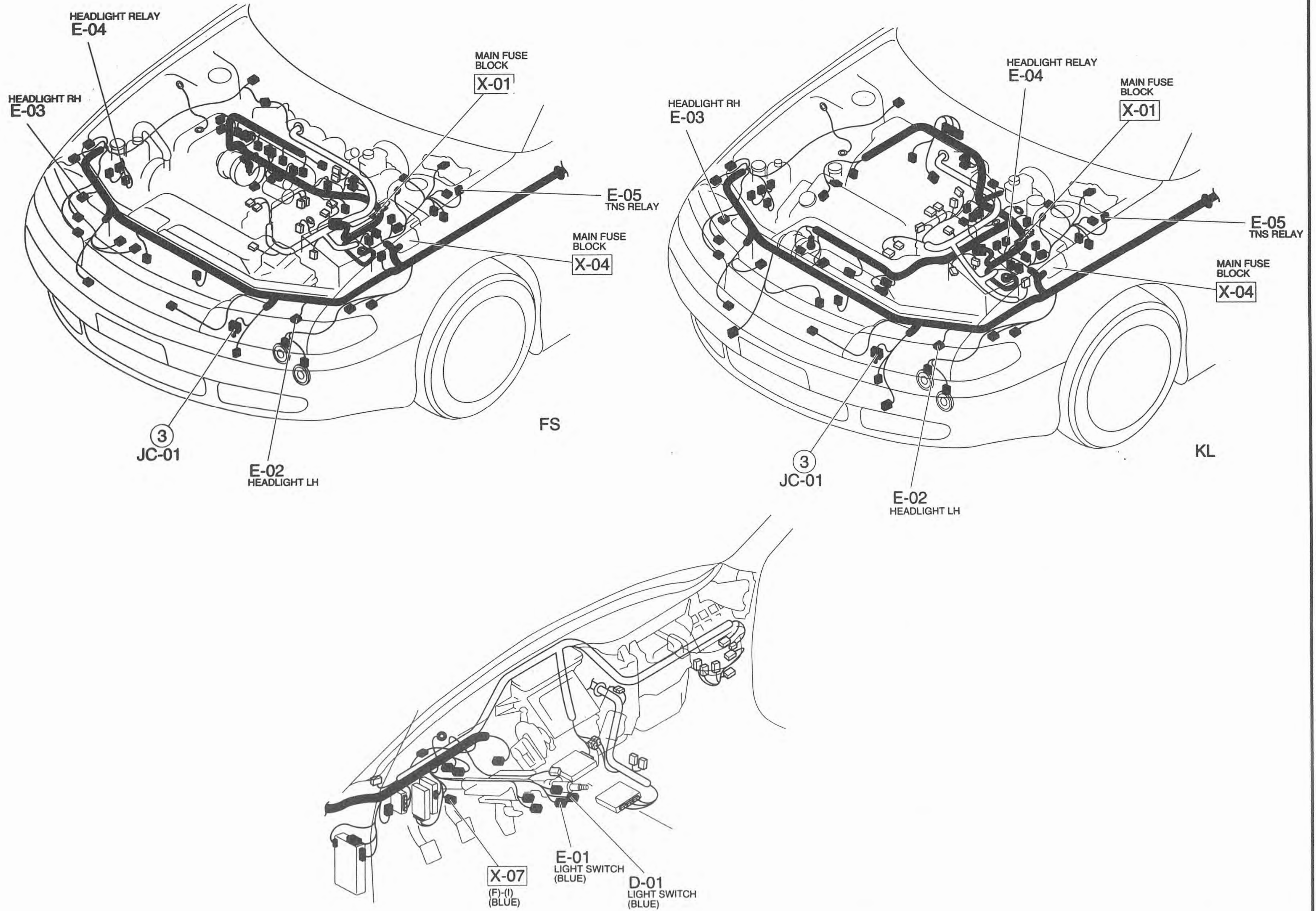

Z WIRING DIAGRAM

E-5

KL ■ FRONT FOG LIGHTS

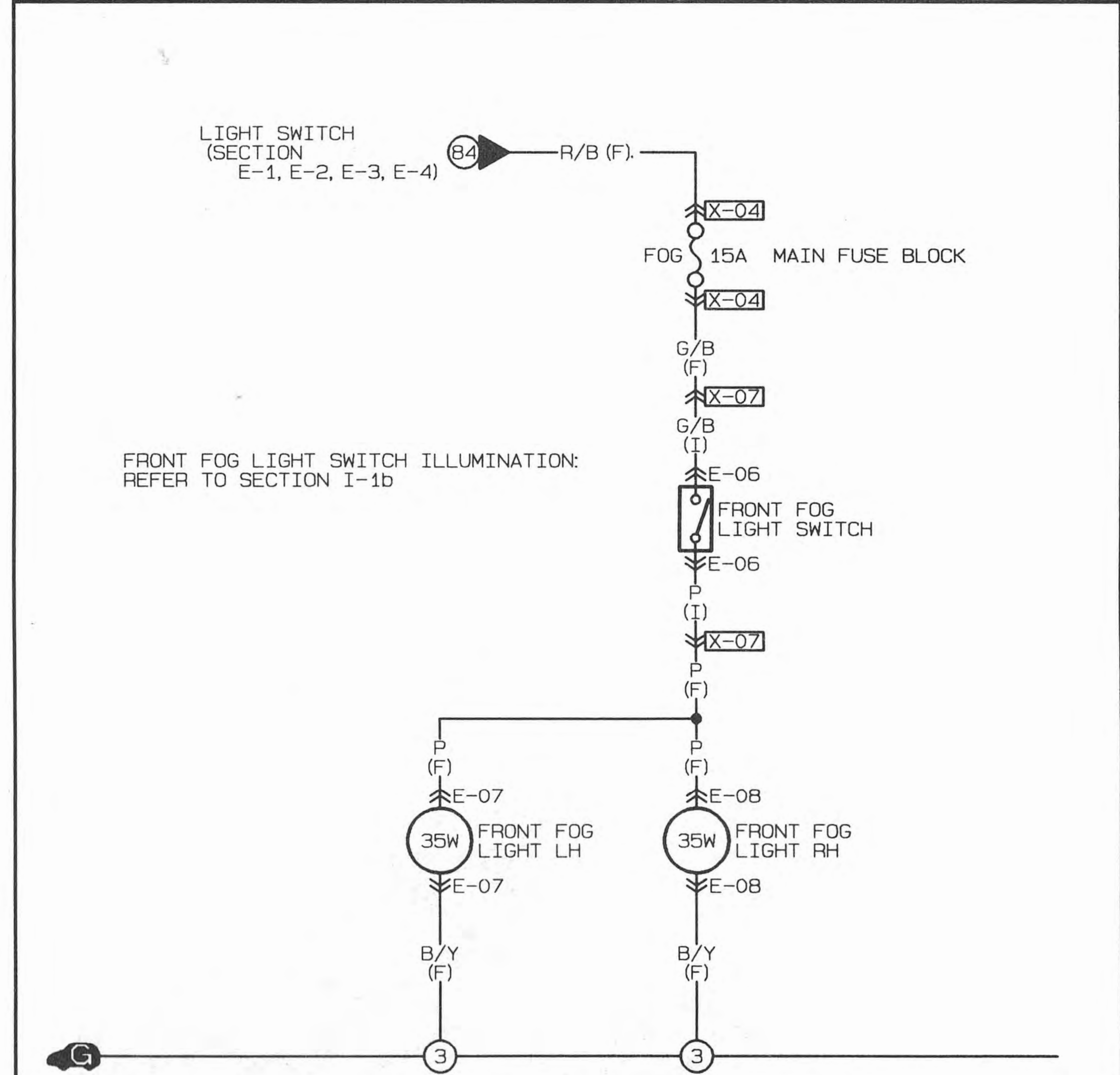

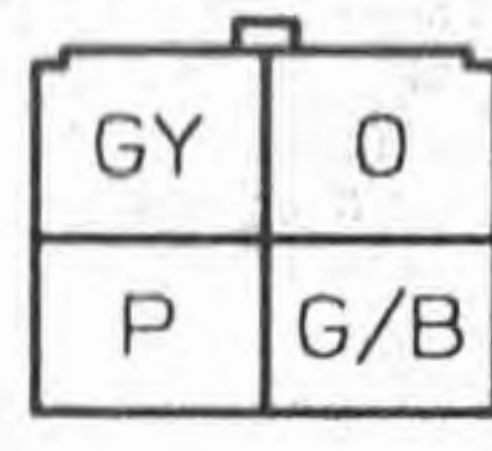
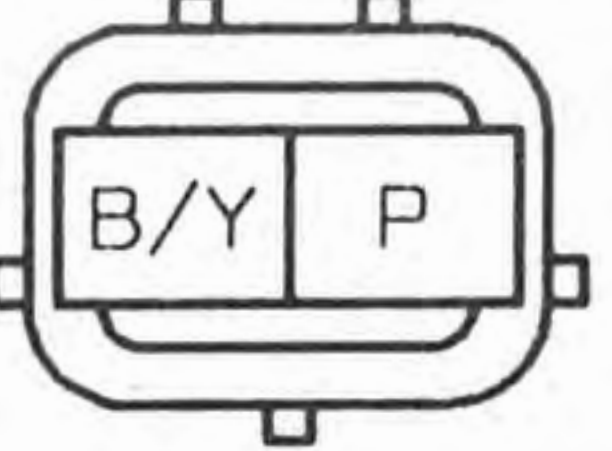
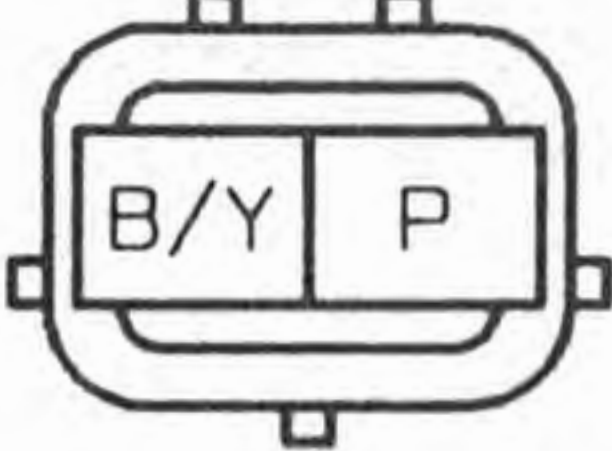
E-06 FRONT FOG LIGHT SWITCH (I)	E-07 FRONT FOG LIGHT LH (F)	E-08 FRONT FOG LIGHT RH (F)	
			

E-5

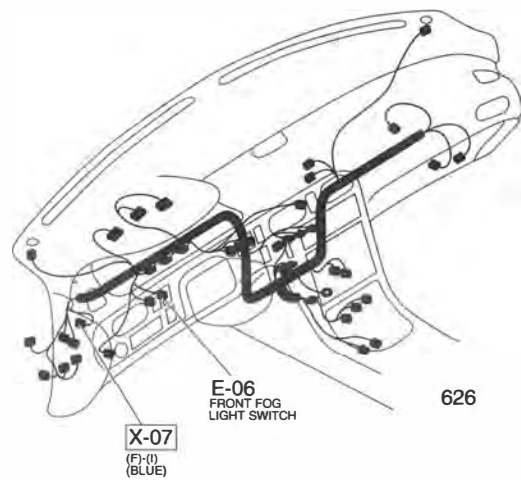
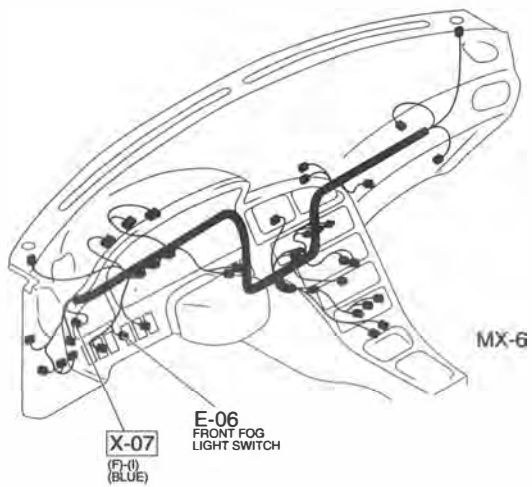
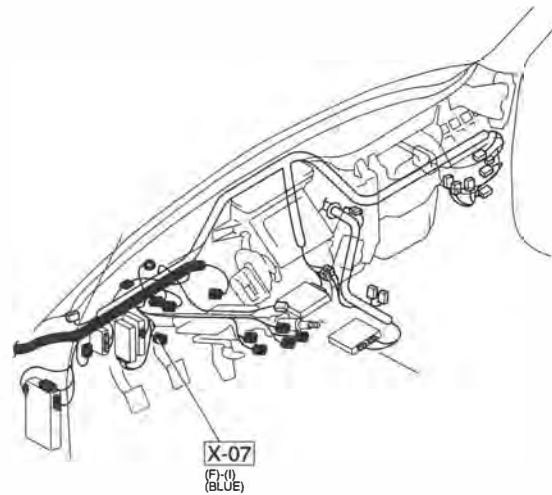
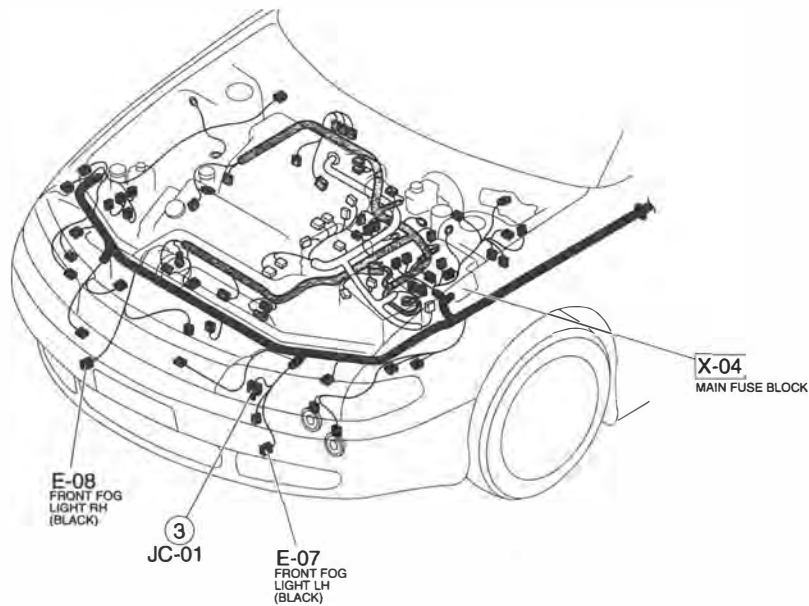

E-6 CANADA DAYTIME RUNNING LIGHT (DRL)

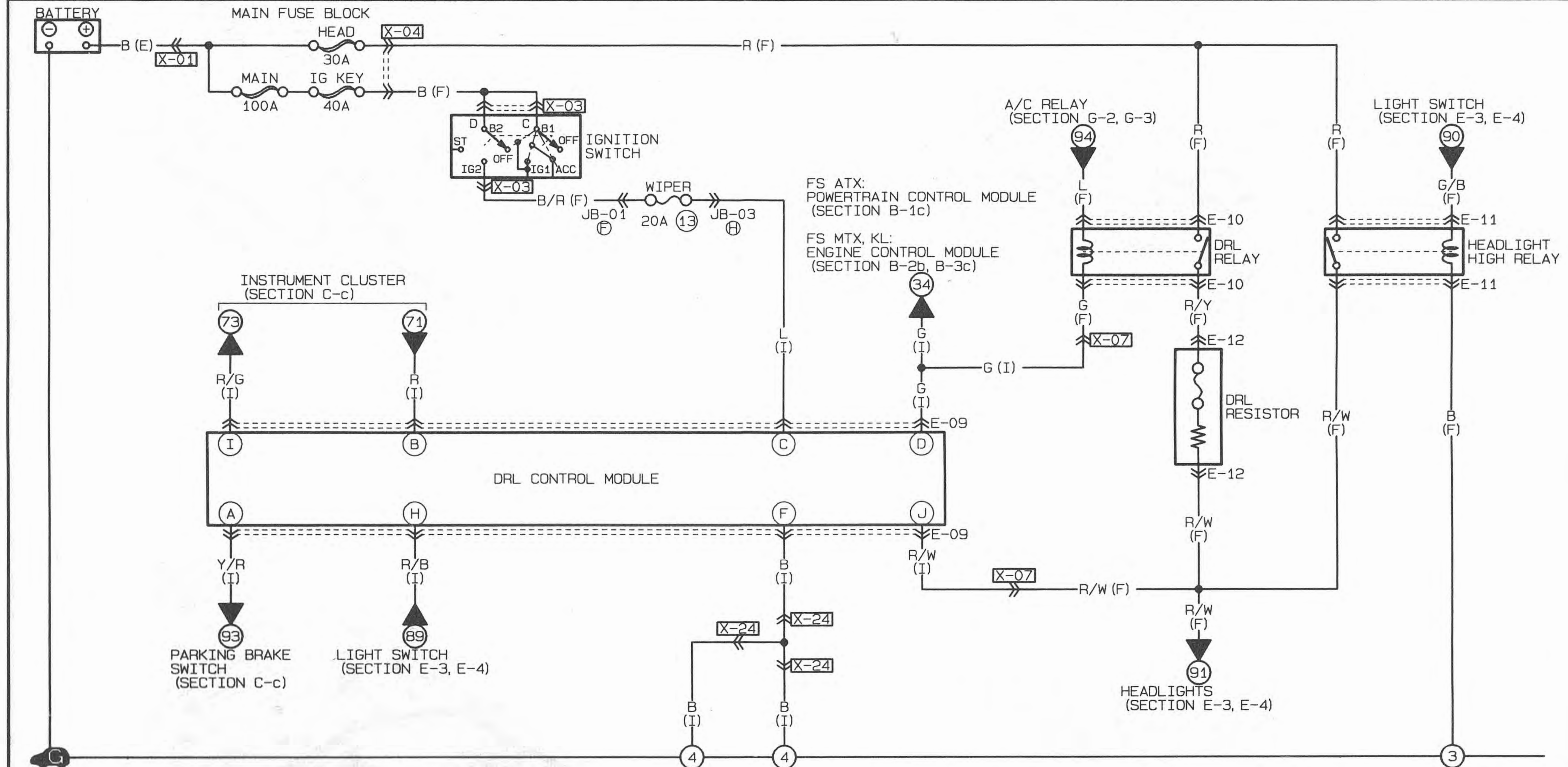

<p>E-09 DRL CONTROL MODULE (I)</p> <table border="1"> <tr> <td>I</td> <td>C</td> <td>A</td> </tr> <tr> <td>R/G</td> <td>L</td> <td>Y/R</td> </tr> <tr> <td>R/W</td> <td>R/B</td> <td>B</td> </tr> <tr> <td>J</td> <td>H</td> <td>F</td> </tr> <tr> <td></td> <td>D</td> <td>B</td> </tr> </table>	I	C	A	R/G	L	Y/R	R/W	R/B	B	J	H	F		D	B	<p>E-10 DRL RELAY (F)</p> <table border="1"> <tr> <td>R</td> <td>L</td> </tr> <tr> <td>R/Y</td> <td>G</td> </tr> </table>	R	L	R/Y	G	<p>E-11 HEADLIGHT HIGH RELAY (F)</p> <table border="1"> <tr> <td>R/W</td> <td>R</td> <td>B</td> </tr> <tr> <td>*</td> <td>*</td> <td>G/B</td> </tr> </table>	R/W	R	B	*	*	G/B	<p>E-12 DRL RESISTOR (F)</p>		
I	C	A																												
R/G	L	Y/R																												
R/W	R/B	B																												
J	H	F																												
	D	B																												
R	L																													
R/Y	G																													
R/W	R	B																												
*	*	G/B																												

E-6

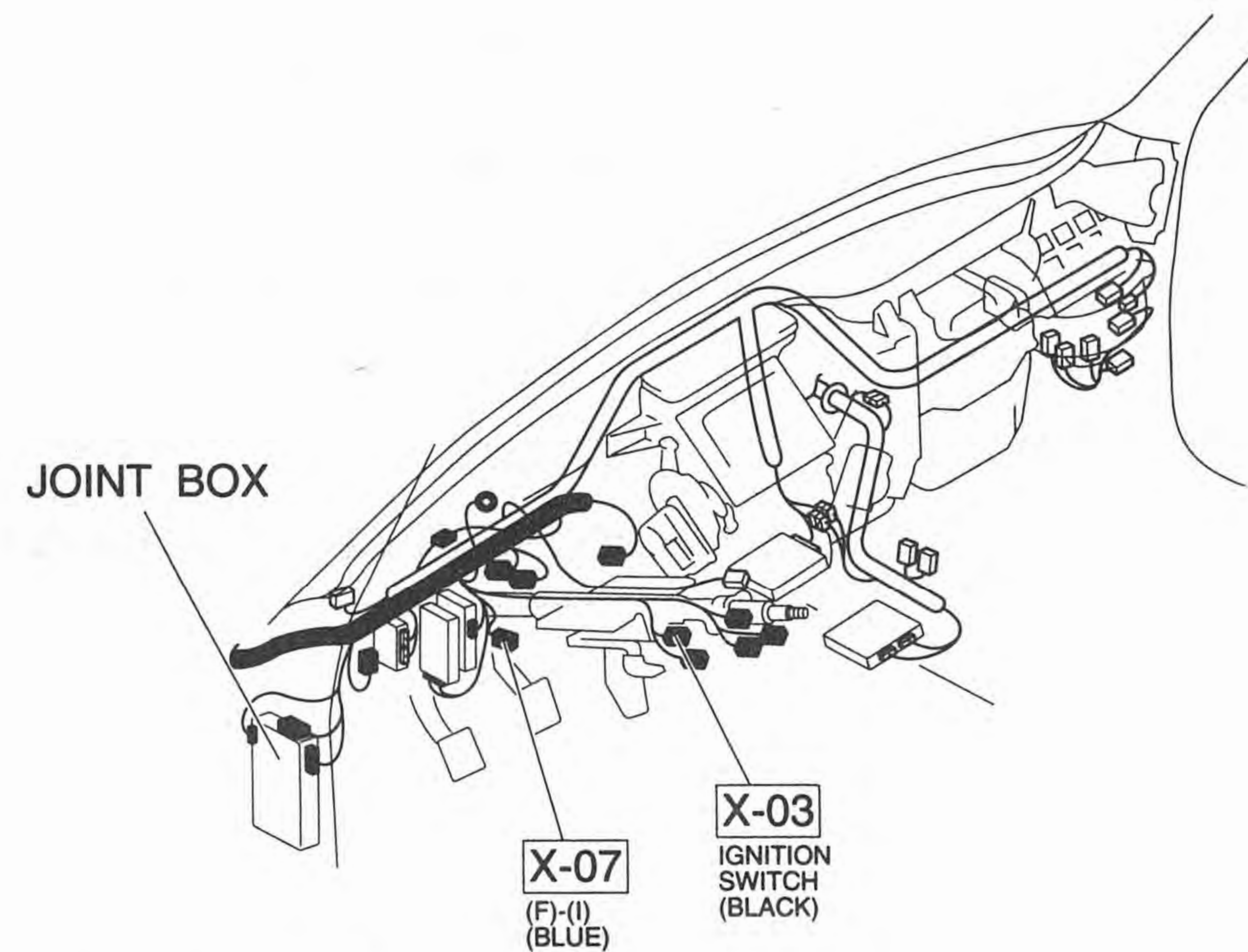
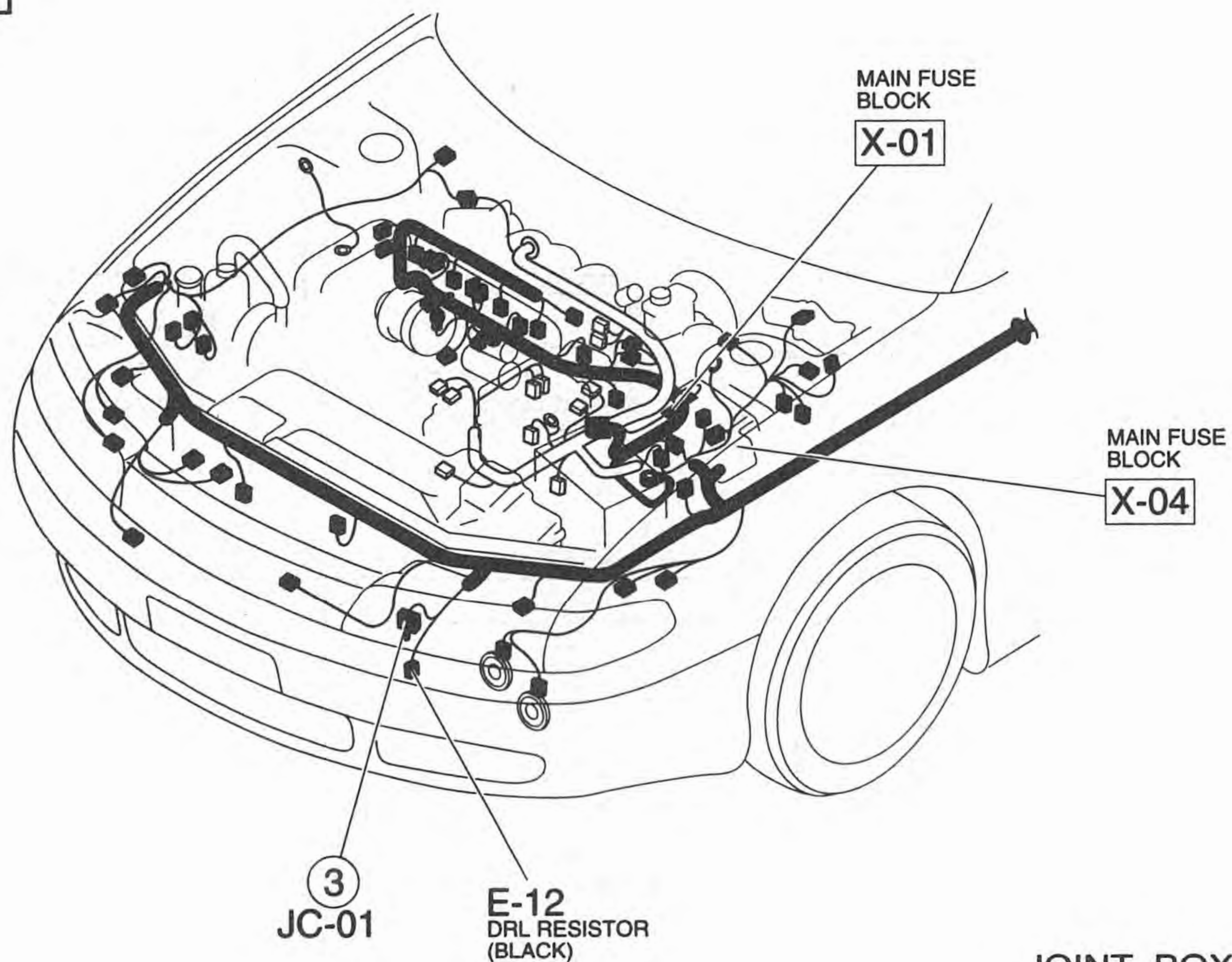

JOINT BOX

MAIN FUSE BOX

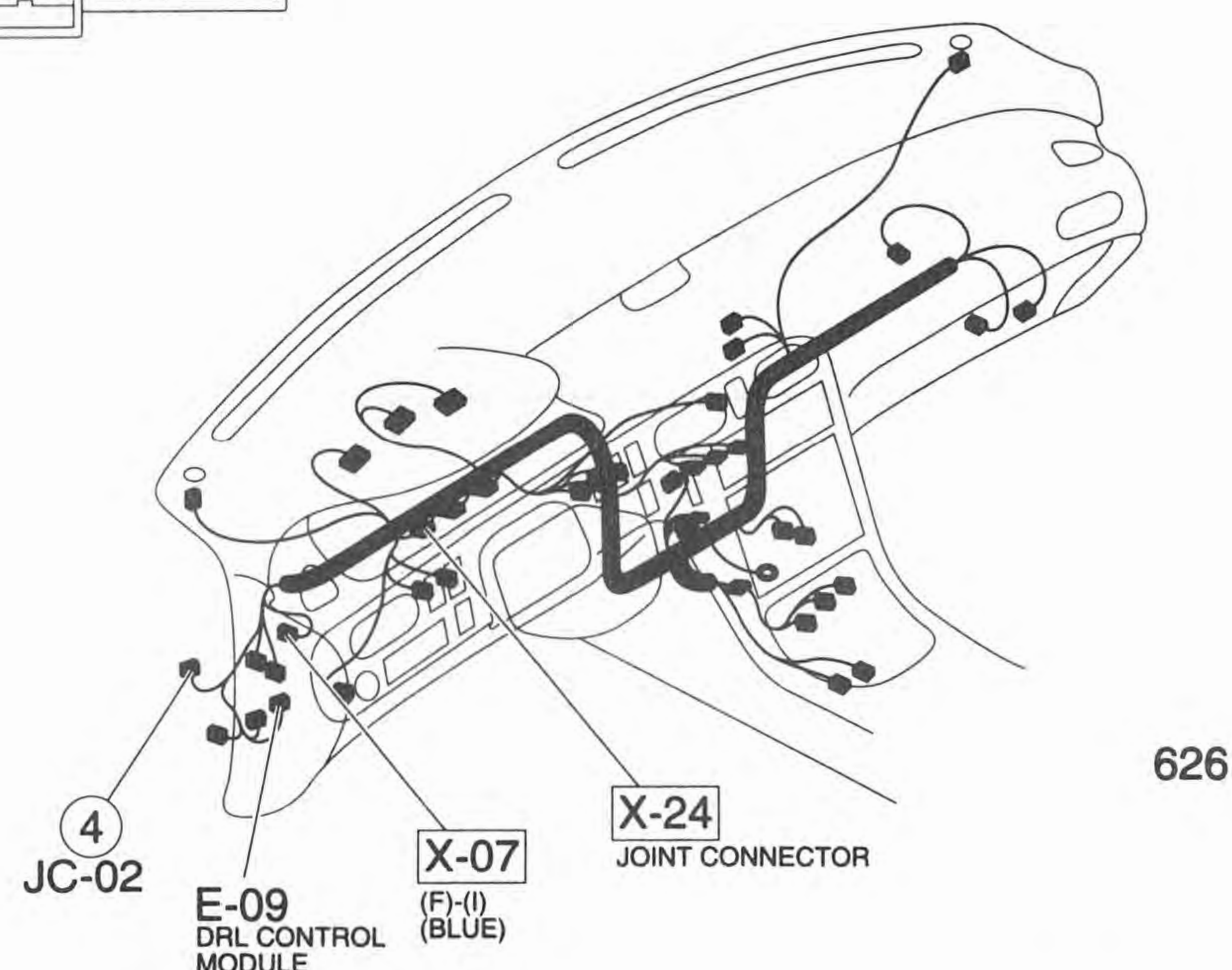
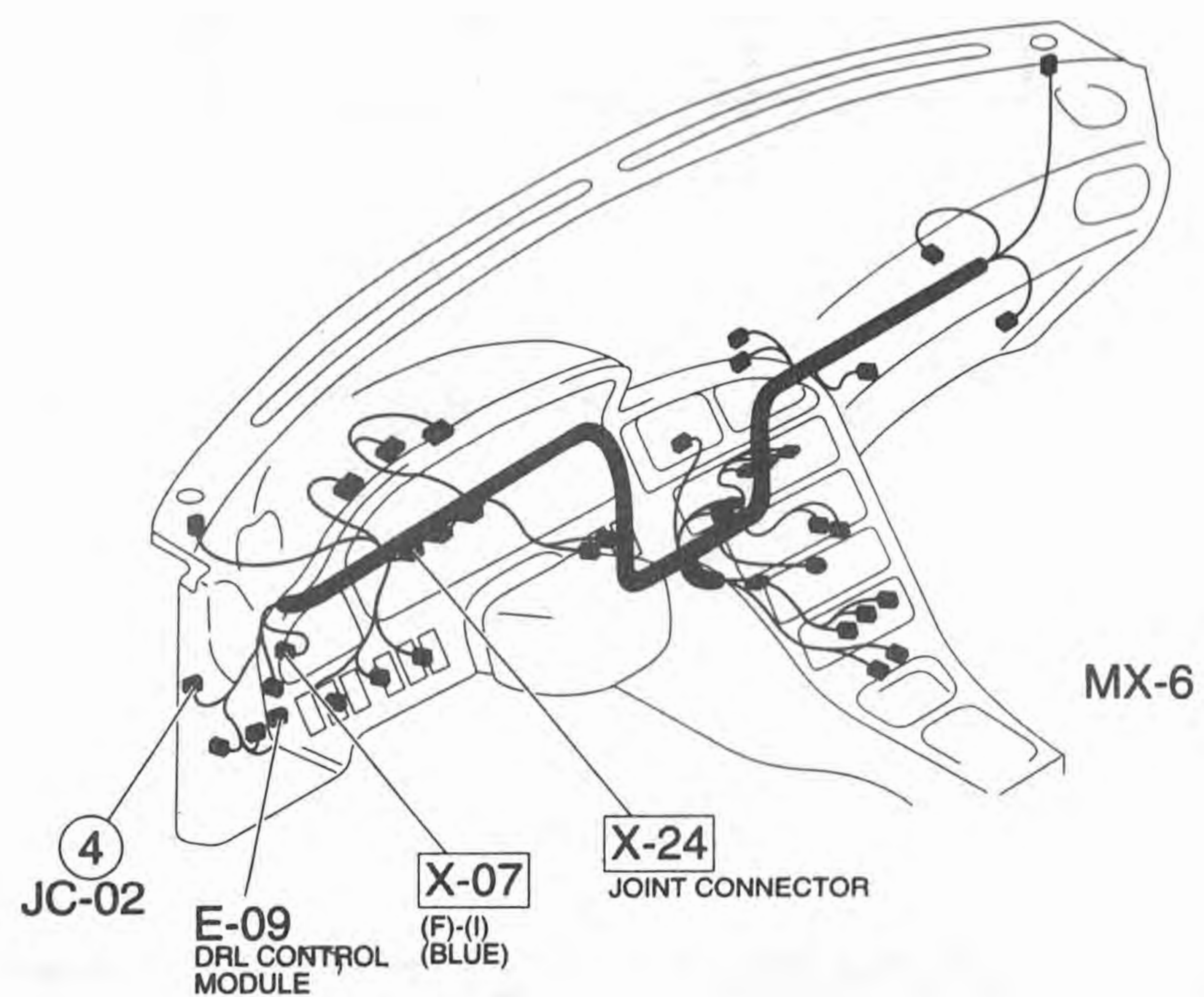
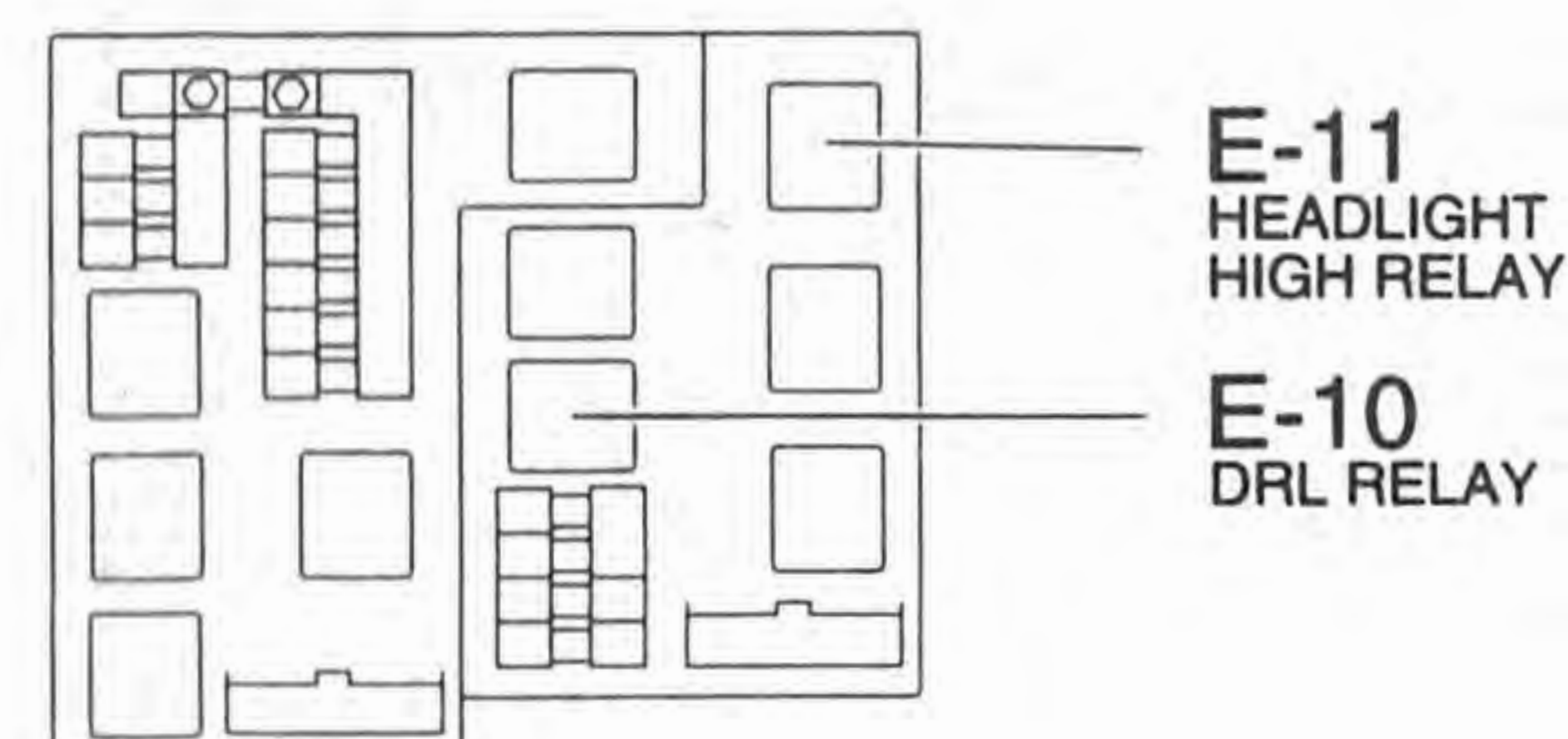
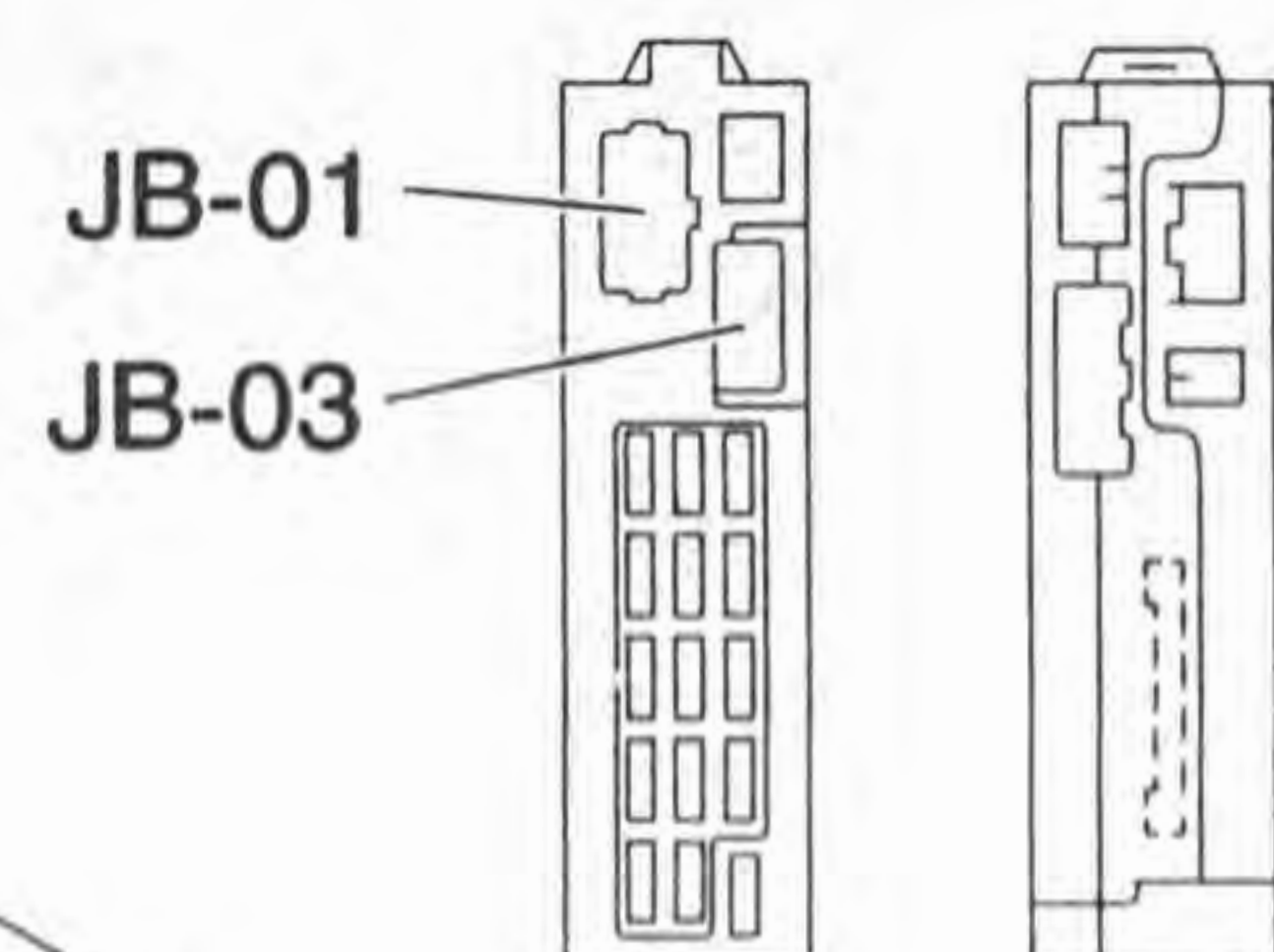

Z WIRING DIAGRAM

E-7 626 ■ FRONT SIDE MARKER LIGHTS ■ PARKING LIGHTS ■ TAILLIGHTS
 ■ REAR SIDE MARKER LIGHTS ■ LICENCE PLATE LIGHTS

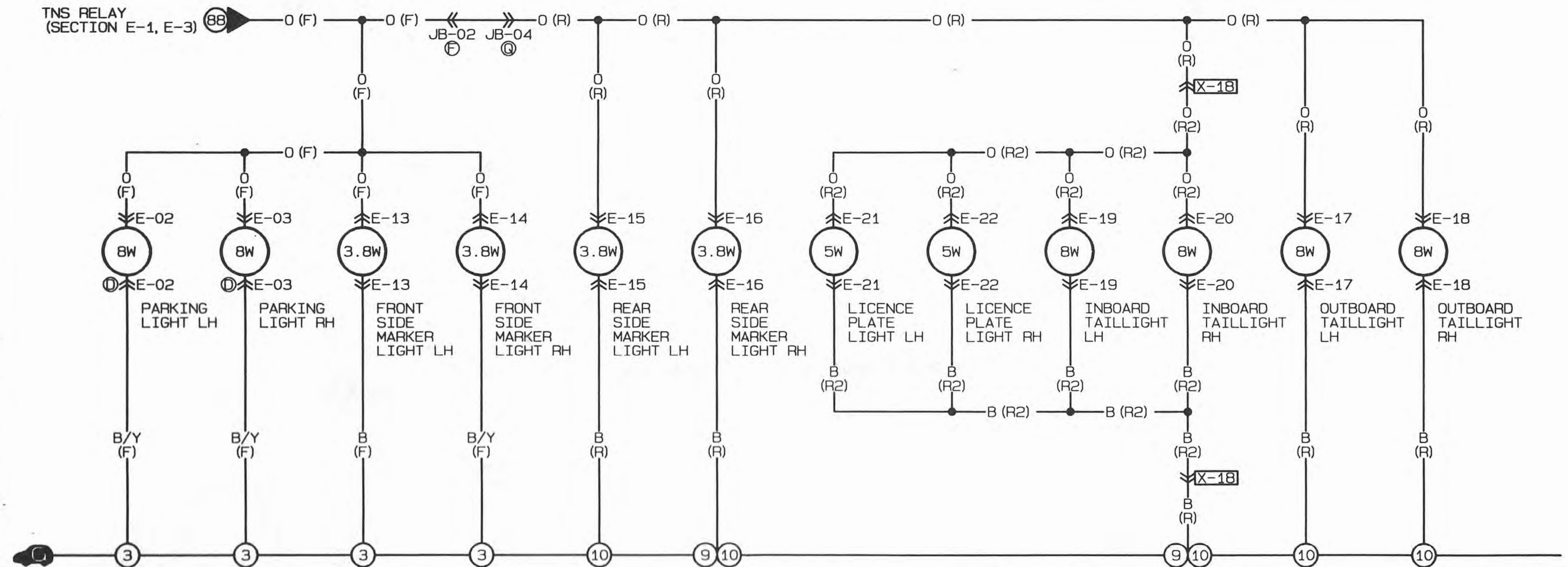

<p>E-02 PARKING LIGHT LH (F)</p>	<p>E-03 PARKING LIGHT RH (F)</p>	<p>E-13 FRONT SIDE MARKER LIGHT LH (F)</p>	<p>E-14 FRONT SIDE MARKER LIGHT RH (F)</p>	<p>E-15 REAR SIDE MARKER LIGHT LH (R)</p>	<p>E-16 REAR SIDE MARKER LIGHT RH (R)</p>	<p>E-17 OUTBOARD TAILLIGHT LH (R)</p>
		<p>E-18 OUTBOARD TAILLIGHT RH (R)</p>	<p>E-19 INBOARD TAILLIGHT LH (R2)</p>	<p>E-20 INBOARD TAILLIGHT RH (R2)</p>	<p>E-21 LICENCE PLATE LIGHT LH (R2)</p>	<p>E-22 LICENCE PLATE LIGHT RH (R2)</p>

E-7

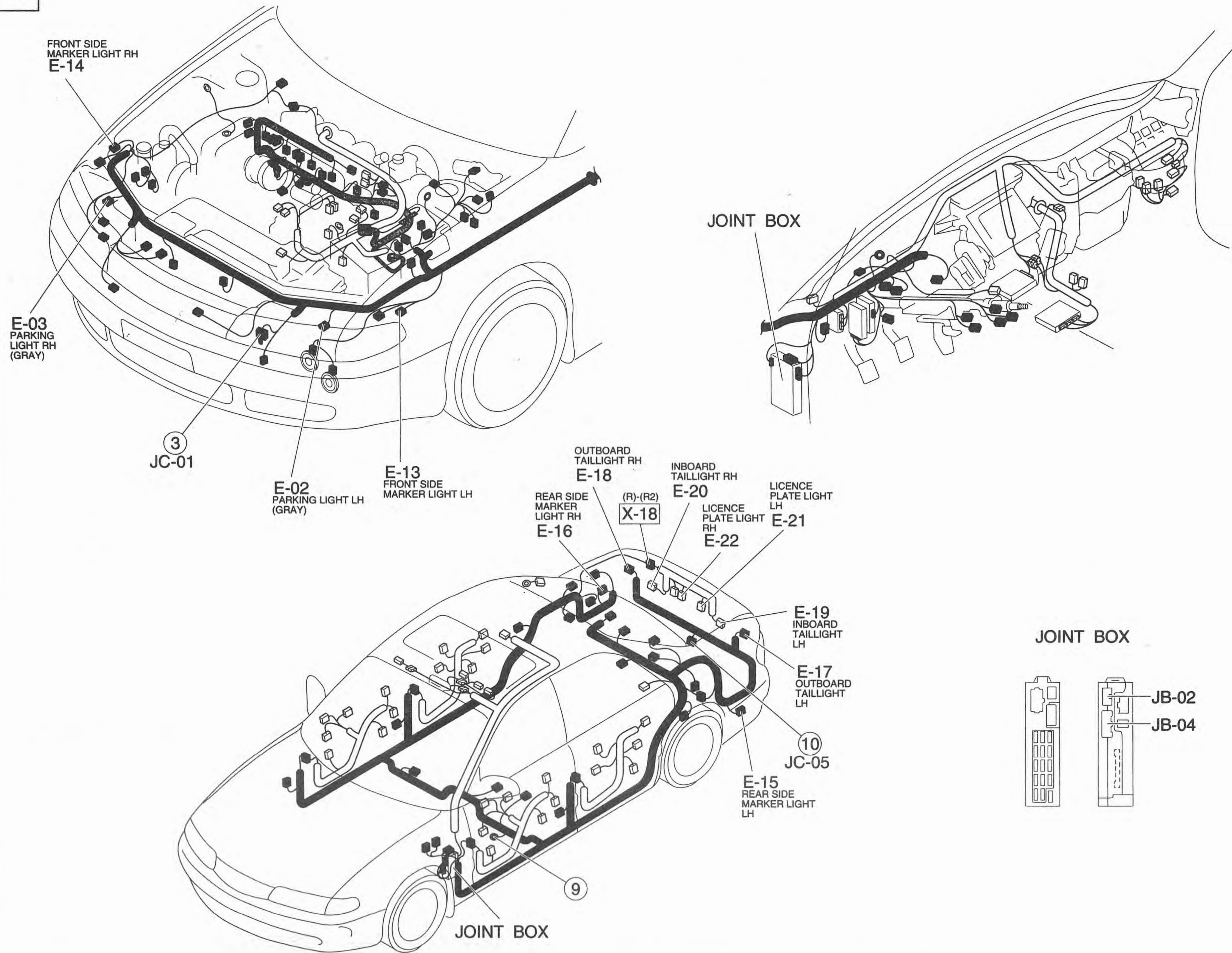

Z WIRING DIAGRAM

E-8

MX-6

■ FRONT SIDE MARKER LIGHTS
■ REAR SIDE MARKER LIGHTS

■ PARKING LIGHTS
■ LICENCE PLATE LIGHTS

■ TAILLIGHTS

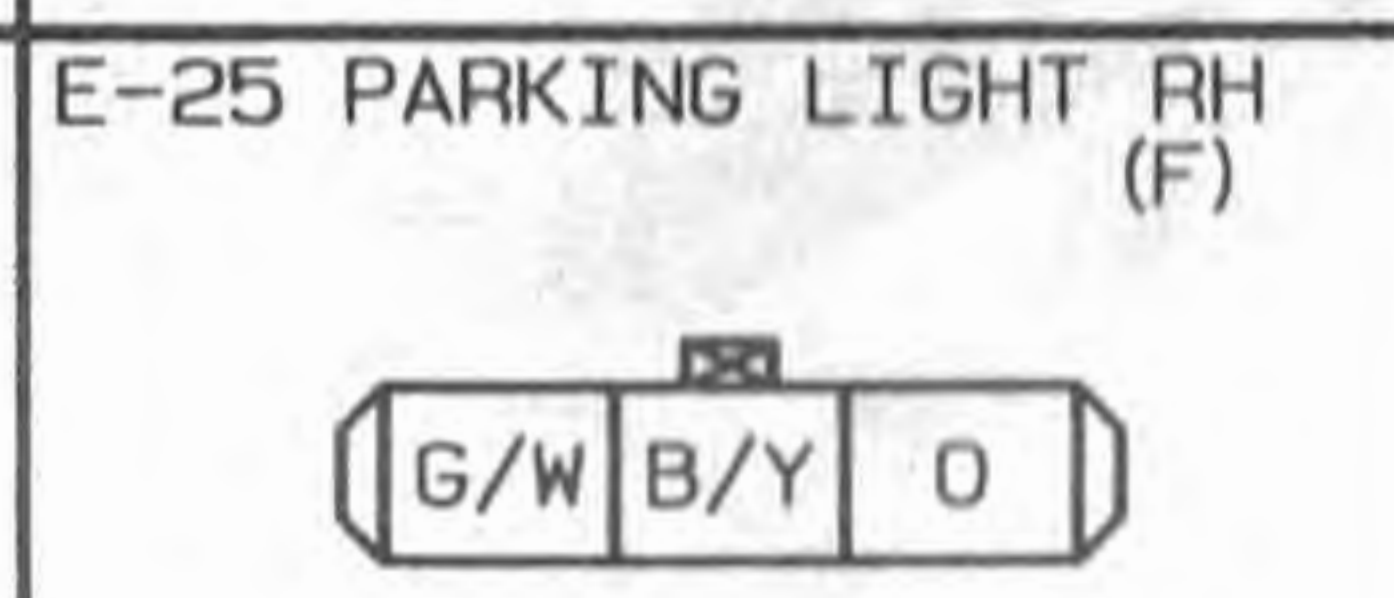
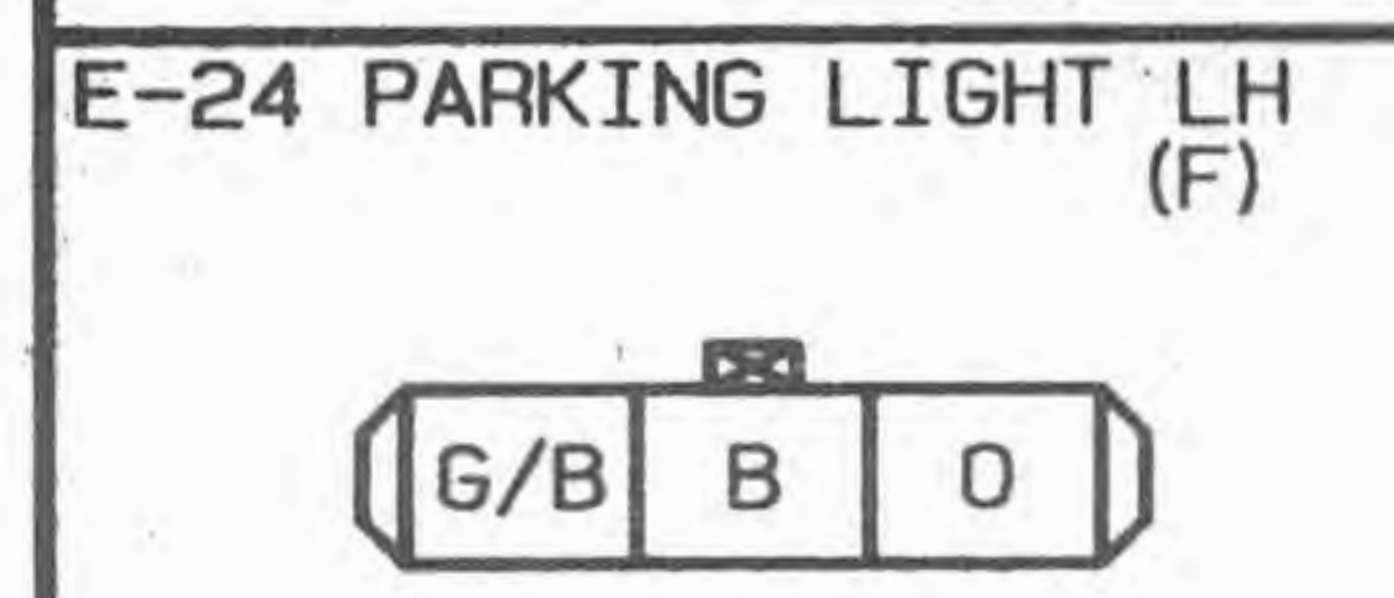
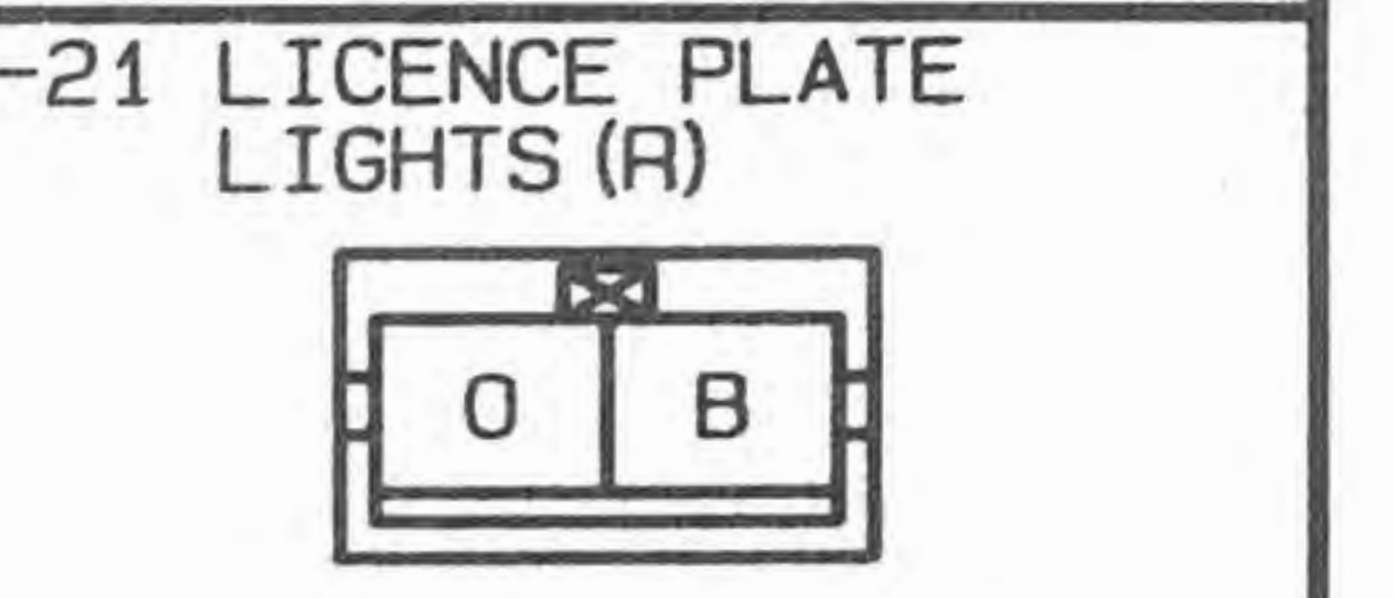
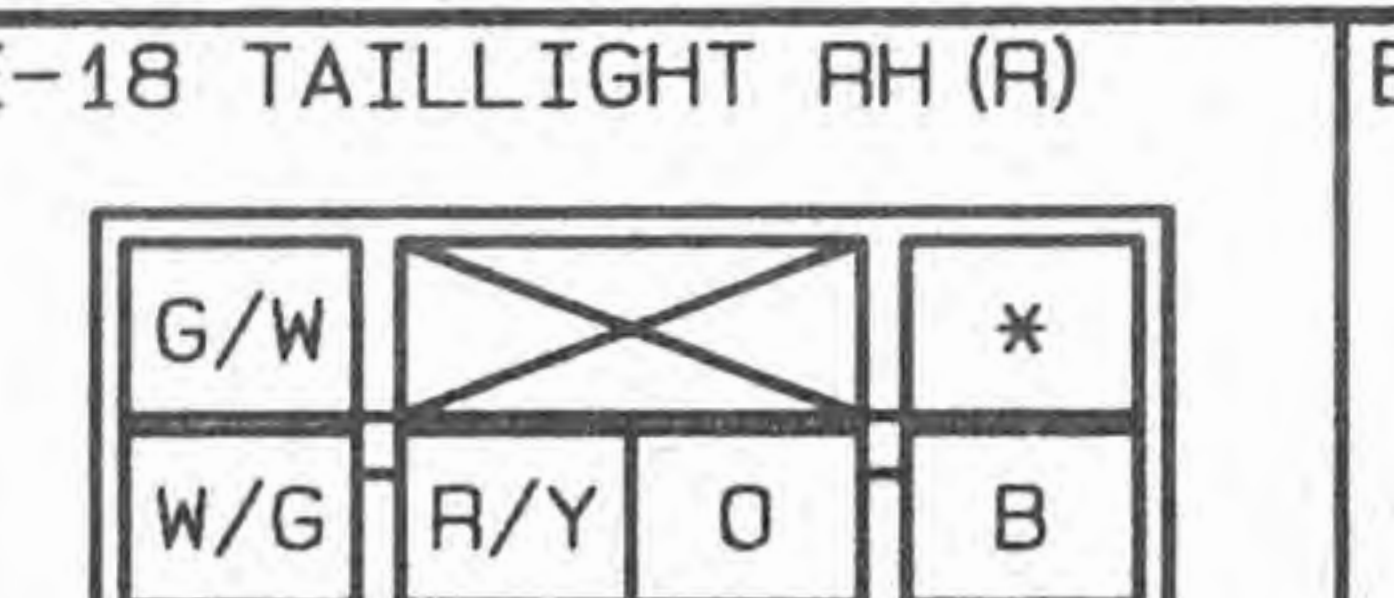
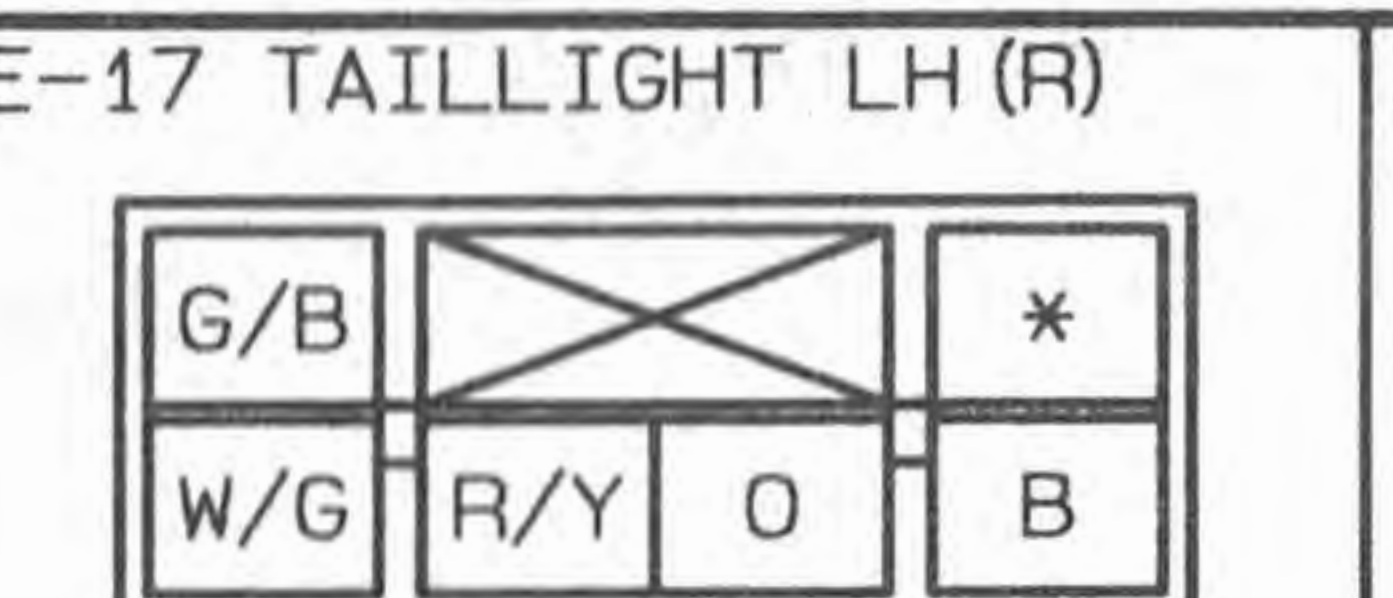
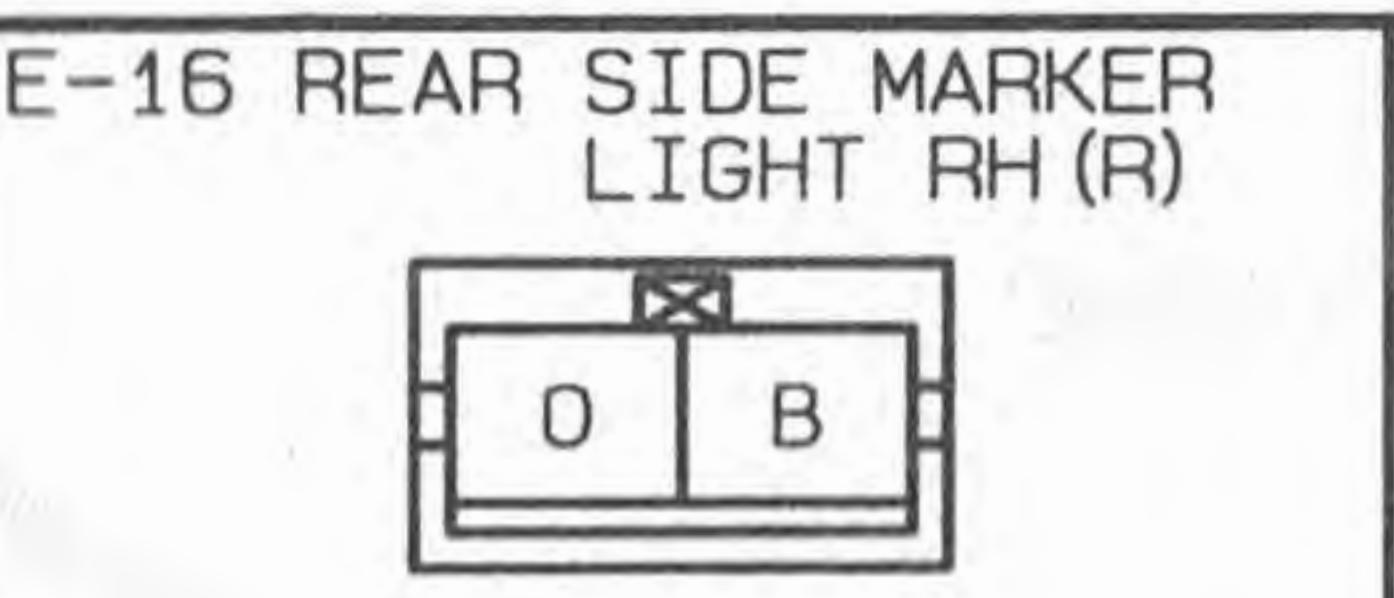
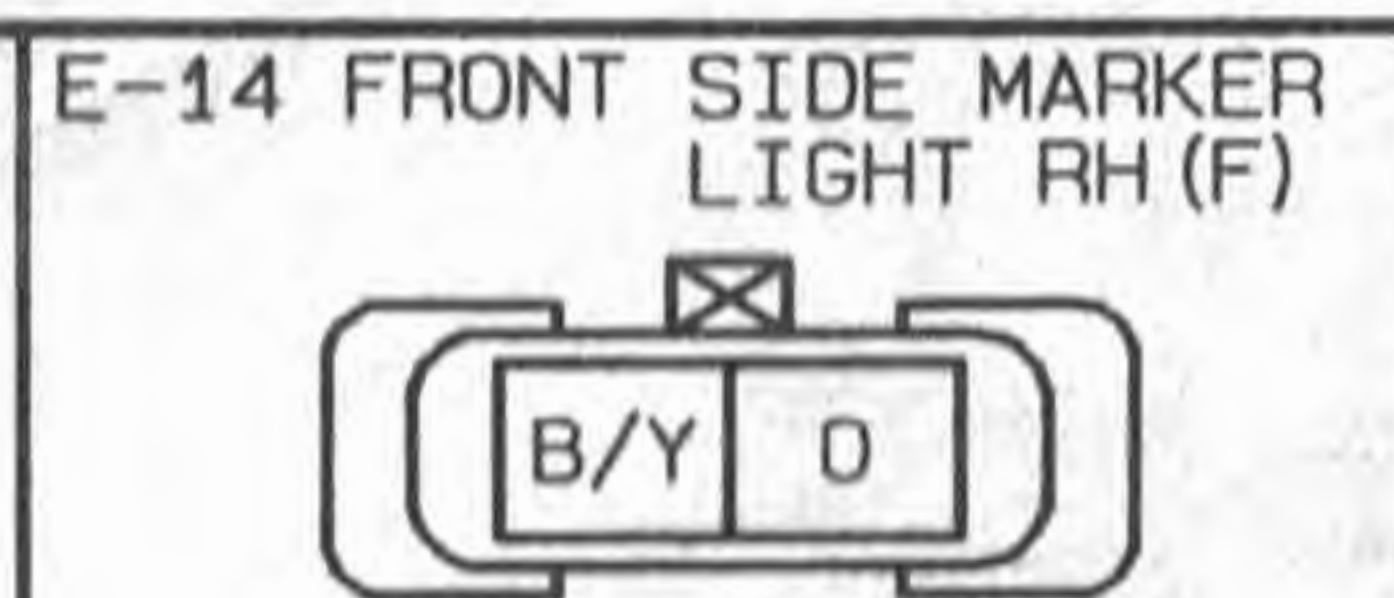
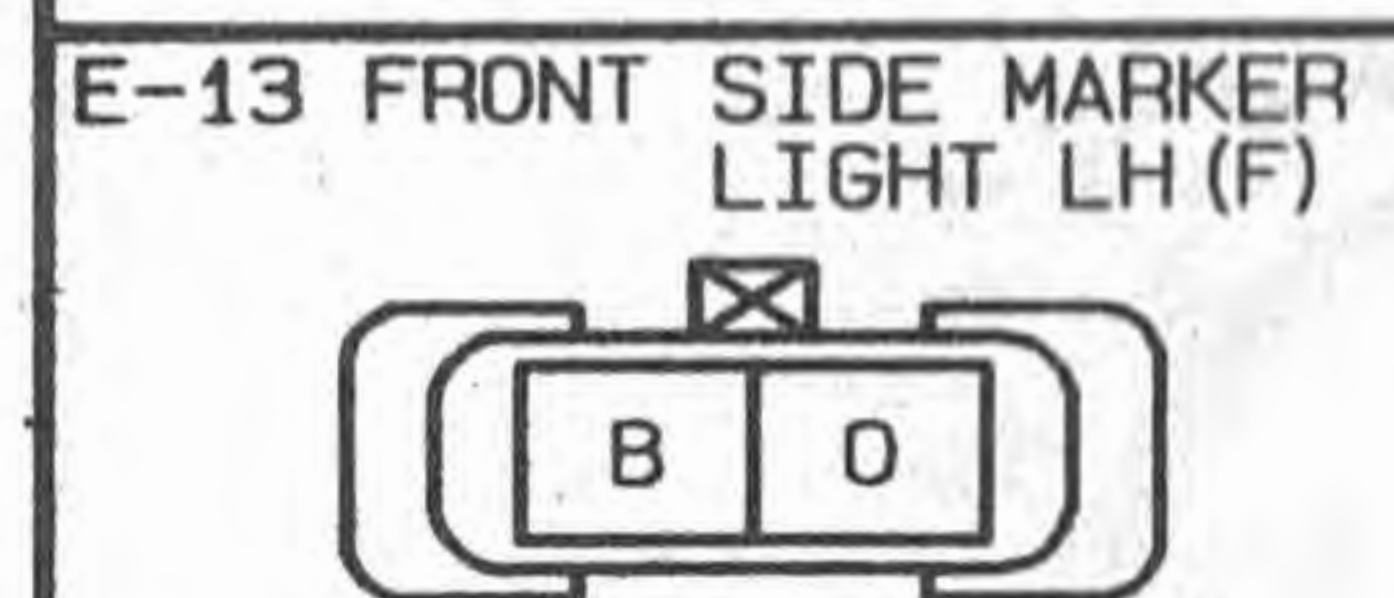
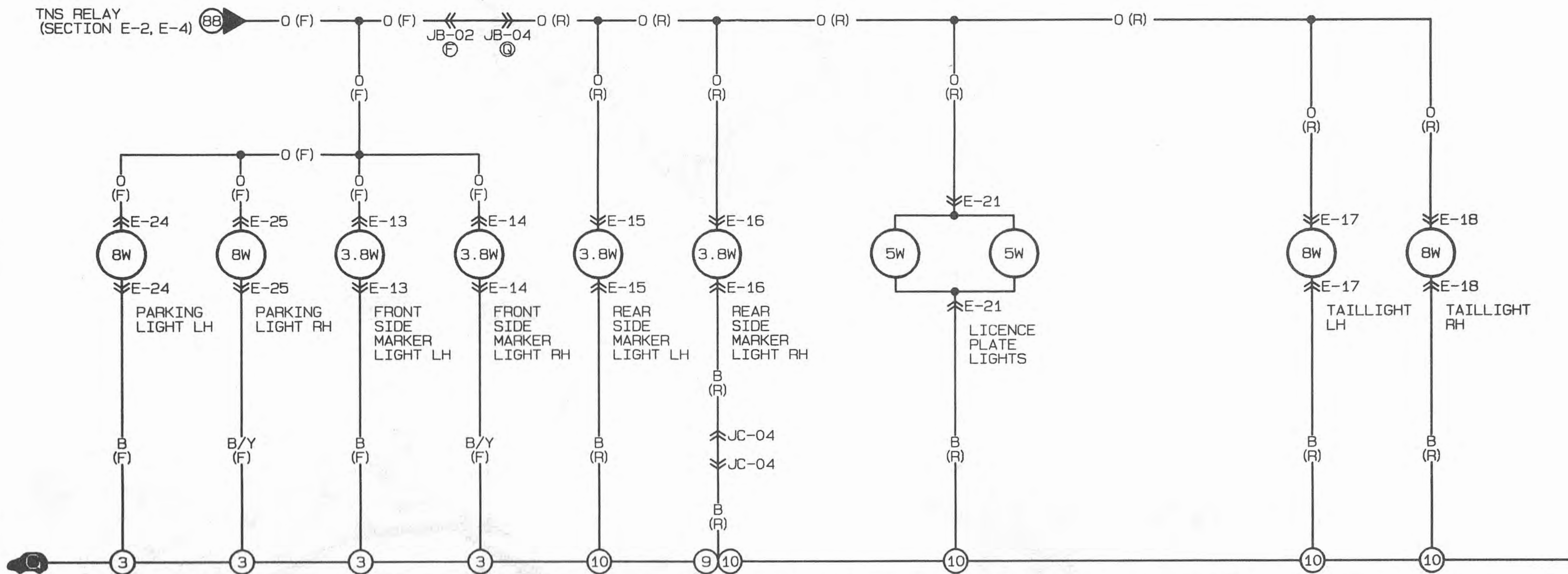

E-8

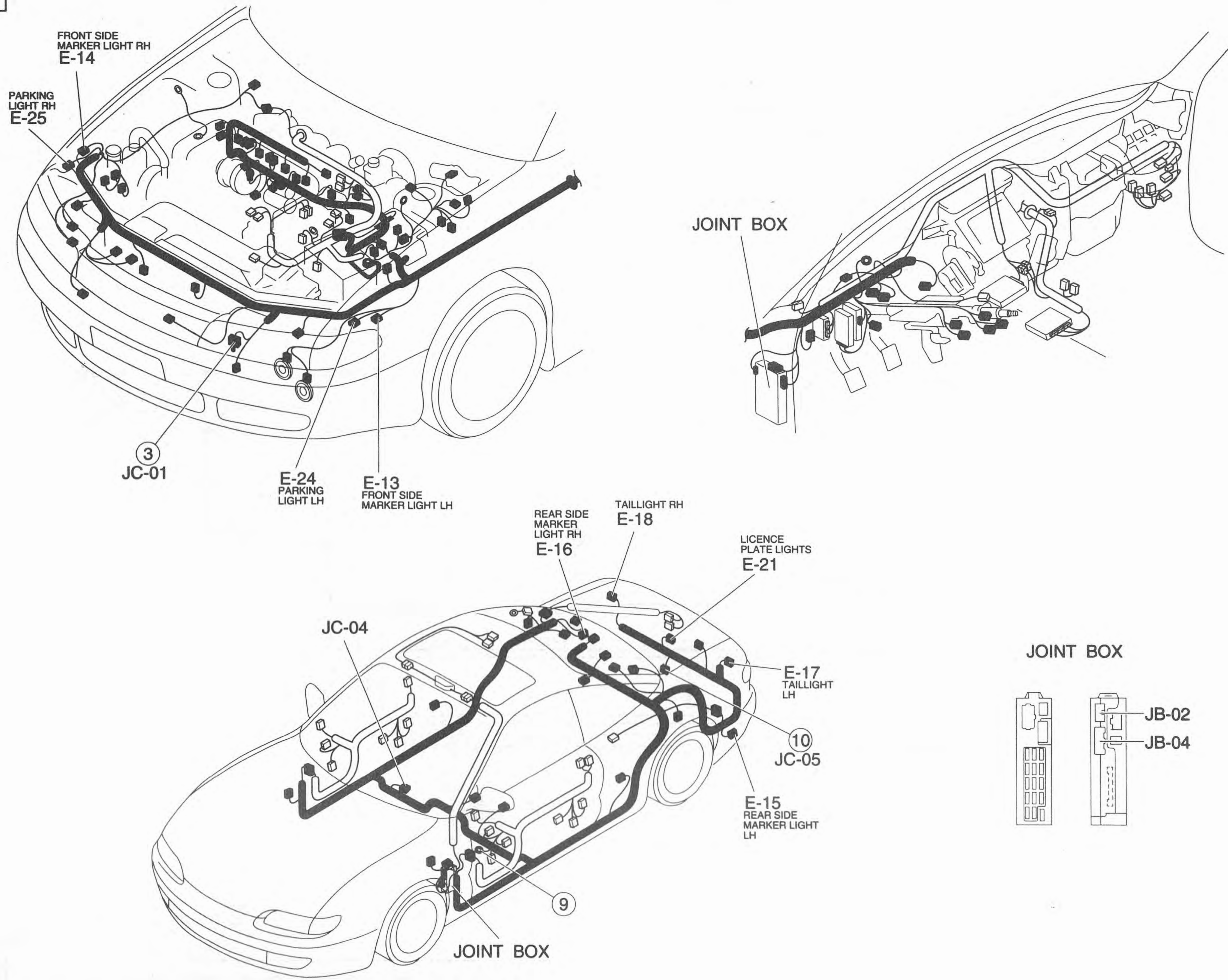

F-1 ■ TURN AND HAZARD WARNING LIGHTS

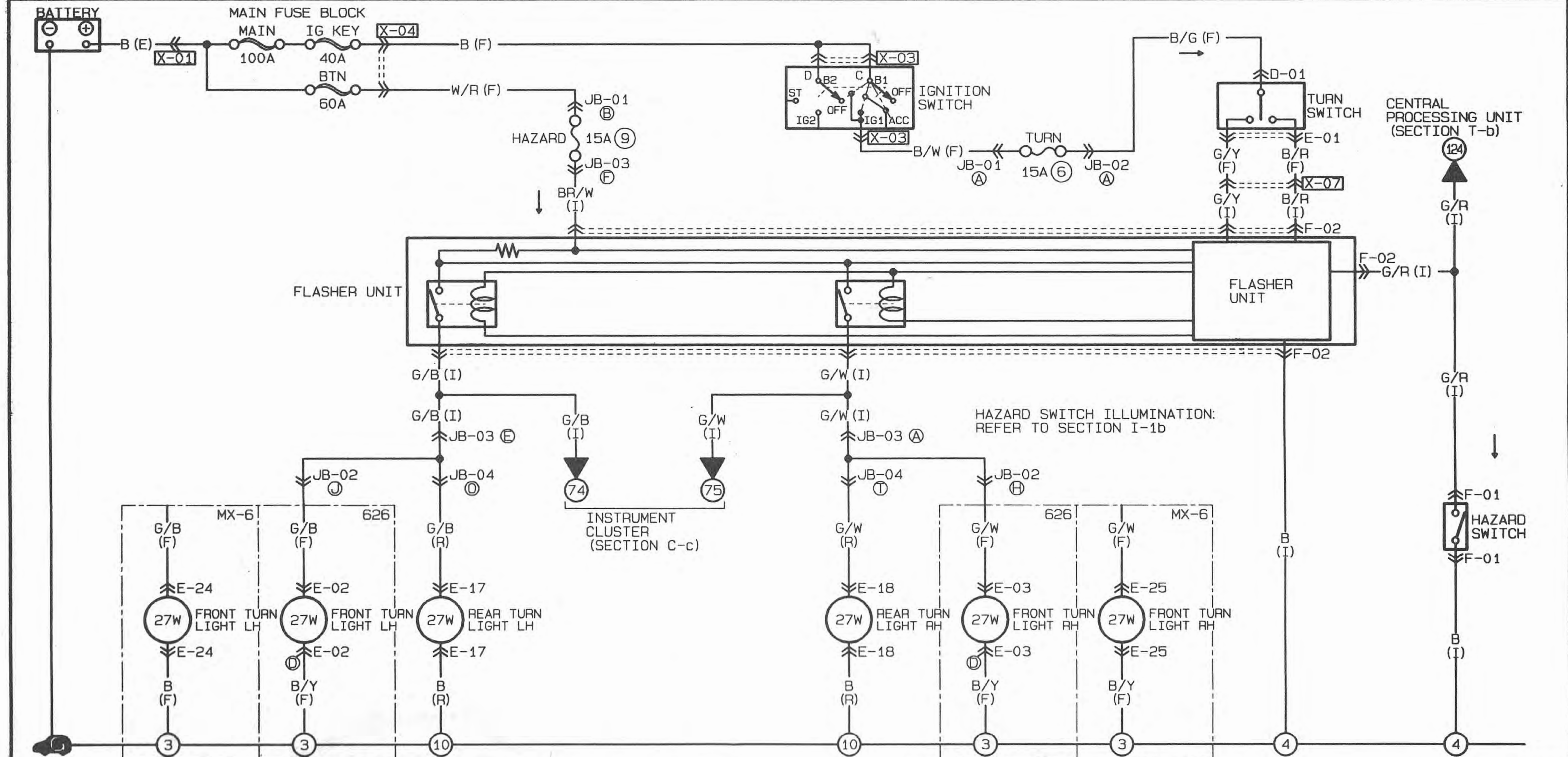

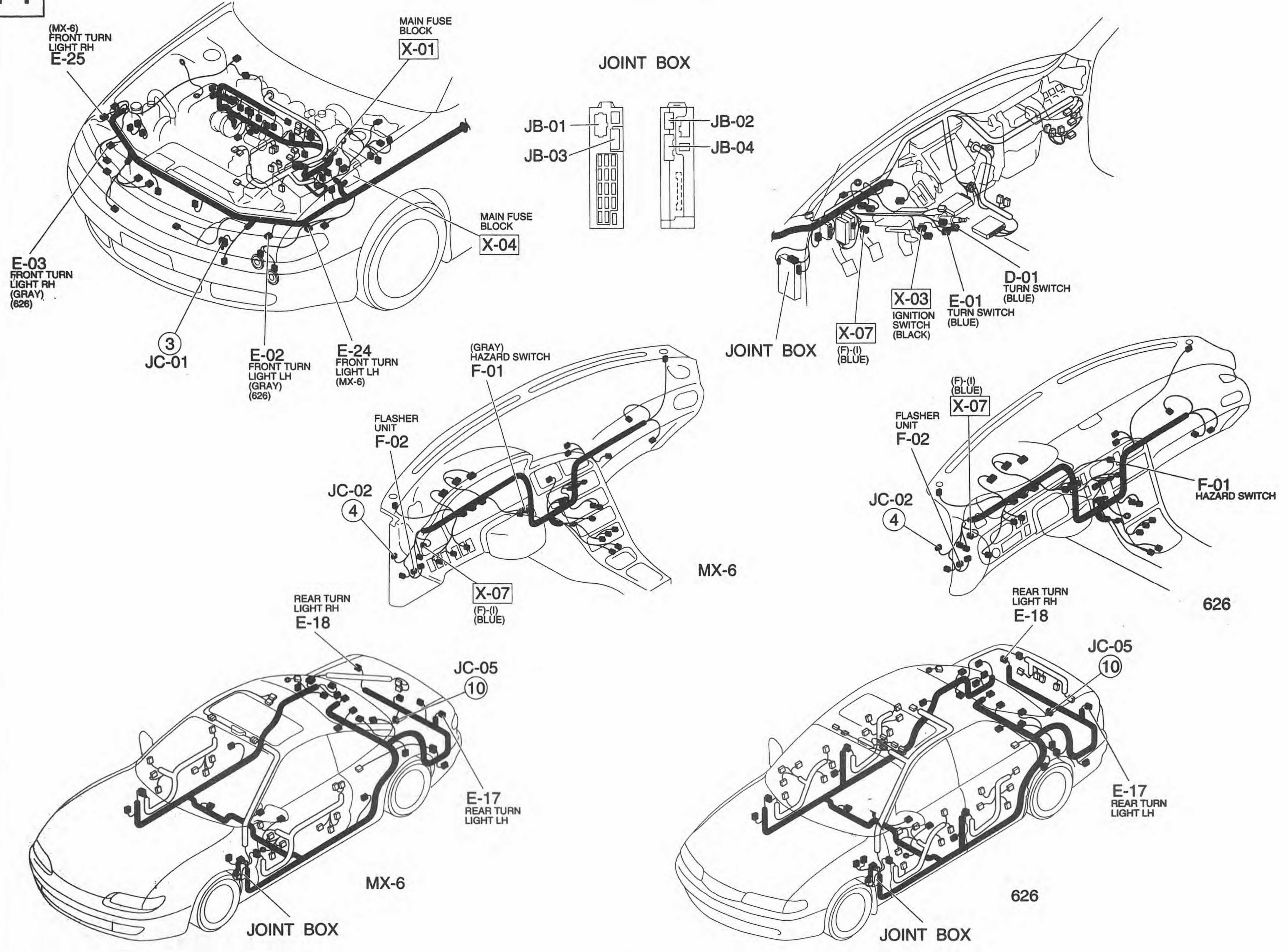

<p>F-01 HAZARD SWITCH (I)</p> <table border="1"> <tr><td>0</td><td>GY</td><td>B</td><td>G/R</td></tr> </table>	0	GY	B	G/R	<p>F-02 FLASHER UNIT (I)</p> <table border="1"> <tr><td>G/W</td><td>B/R</td><td>G/R</td><td>B</td></tr> <tr><td>BR/W</td><td>G/Y</td><td>G/B</td><td>*</td></tr> </table>	G/W	B/R	G/R	B	BR/W	G/Y	G/B	*	<p>D-01 TURN SWITCH (F)</p> <table border="1"> <tr><td>*</td><td>L/O</td><td>L/B</td><td>B</td><td>LG</td><td>L/R</td></tr> <tr><td>*</td><td>L/W</td><td>L/R</td><td>L</td><td>B</td><td>B/G</td><td>W/R</td><td>R/L</td></tr> </table>	*	L/O	L/B	B	LG	L/R	*	L/W	L/R	L	B	B/G	W/R	R/L	<p>E-01 TURN SWITCH (F)</p> <table border="1"> <tr><td>G/Y</td><td>R/B</td></tr> <tr><td>B/R</td><td>W</td><td>R</td><td>R/W</td><td>*G/B</td></tr> </table>	G/Y	R/B	B/R	W	R	R/W	*G/B	<p>E-02 FRONT TURN LIGHT LH (F)</p> <table border="1"> <tr><td>R/W</td><td>W</td><td>G/B</td></tr> <tr><td>B/Y</td><td>B/Y</td><td>0</td></tr> </table>	R/W	W	G/B	B/Y	B/Y	0	<p>E-03 FRONT TURN LIGHT RH (F)</p> <table border="1"> <tr><td>R/W</td><td>W</td><td>G/W</td></tr> <tr><td>B/Y</td><td>B/Y</td><td>0</td></tr> </table>	R/W	W	G/W	B/Y	B/Y	0
0	GY	B	G/R																																															
G/W	B/R	G/R	B																																															
BR/W	G/Y	G/B	*																																															
*	L/O	L/B	B	LG	L/R																																													
*	L/W	L/R	L	B	B/G	W/R	R/L																																											
G/Y	R/B																																																	
B/R	W	R	R/W	*G/B																																														
R/W	W	G/B																																																
B/Y	B/Y	0																																																
R/W	W	G/W																																																
B/Y	B/Y	0																																																
<p>E-17 REAR TURN LIGHT LH (R)</p> <table border="1"> <tr><td>626</td><td>G/B</td><td>W/G</td><td>0</td><td>B</td></tr> <tr><td>MX-6</td><td>G/B</td><td>W/G</td><td>R/Y</td><td>0</td><td>B</td></tr> </table>		626	G/B	W/G	0	B	MX-6	G/B	W/G	R/Y	0	B	<p>E-18 REAR TURN LIGHT RH (R)</p> <table border="1"> <tr><td>626</td><td>G/W</td><td>W/G</td><td>0</td><td>B</td></tr> <tr><td>MX-6</td><td>G/W</td><td>W/G</td><td>R/Y</td><td>0</td><td>B</td></tr> </table>		626	G/W	W/G	0	B	MX-6	G/W	W/G	R/Y	0	B																									
626	G/B	W/G	0	B																																														
MX-6	G/B	W/G	R/Y	0	B																																													
626	G/W	W/G	0	B																																														
MX-6	G/W	W/G	R/Y	0	B																																													
<p>E-24 FRONT TURN LIGHT LH (F)</p> <table border="1"> <tr><td>G/B</td><td>B</td><td>0</td></tr> </table>	G/B	B	0	<p>E-25 FRONT TURN LIGHT RH (F)</p> <table border="1"> <tr><td>G/W</td><td>B/Y</td><td>0</td></tr> </table>	G/W	B/Y	0																																											
G/B	B	0																																																
G/W	B/Y	0																																																

F-1

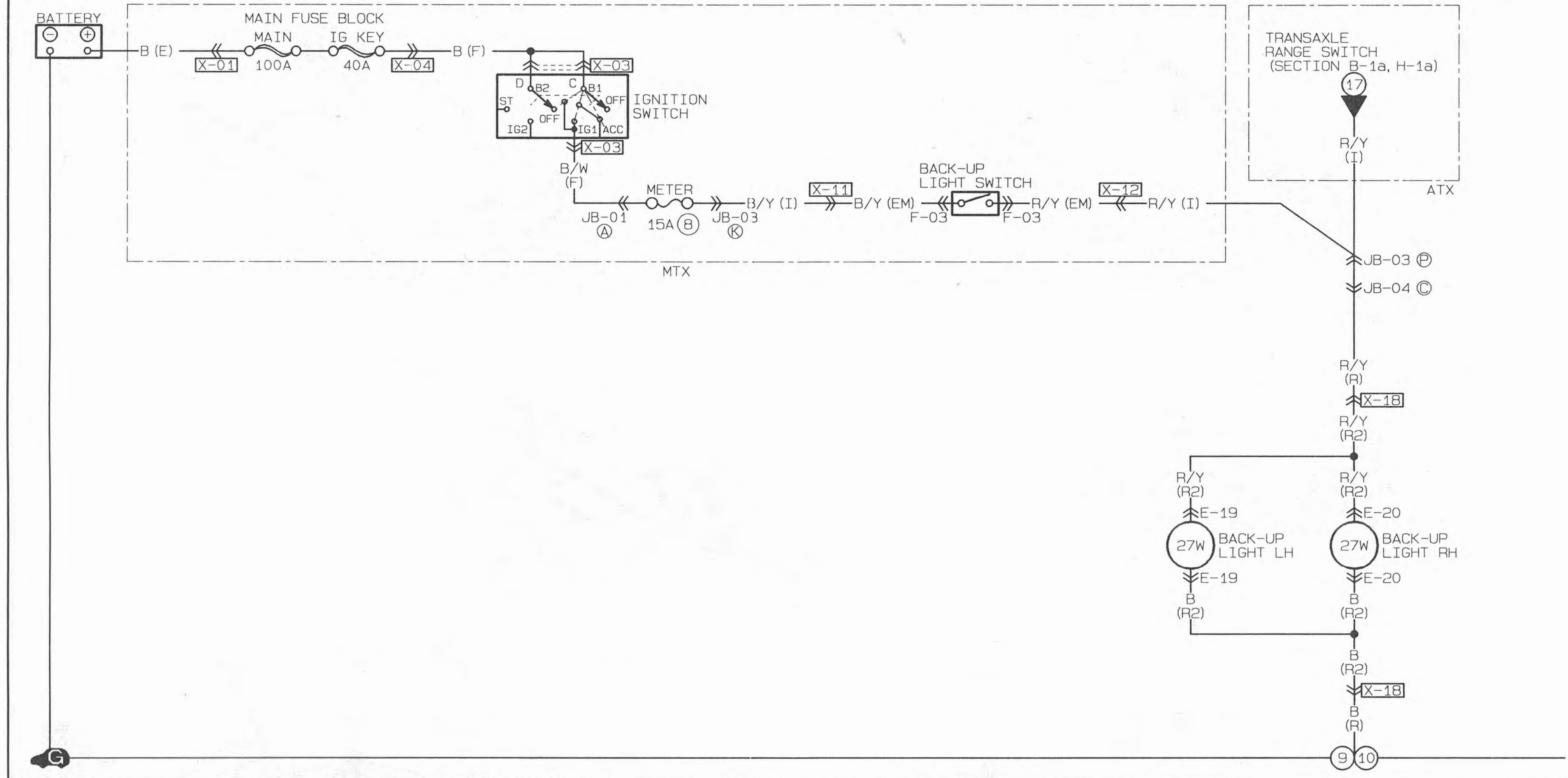

F-2 626 ■ BACK-UP LIGHTS

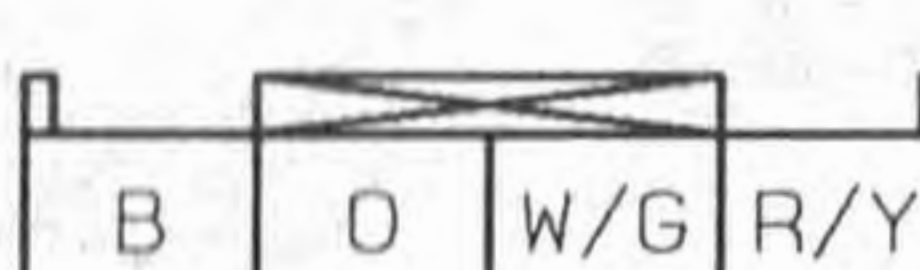

<p>F-03 BACK-UP LIGHT SWITCH (EM)</p> 	<p>E-19 BACK-UP LIGHT LH (R2)</p> 	<p>E-20 BACK-UP LIGHT RH (R2)</p> 				

F-2

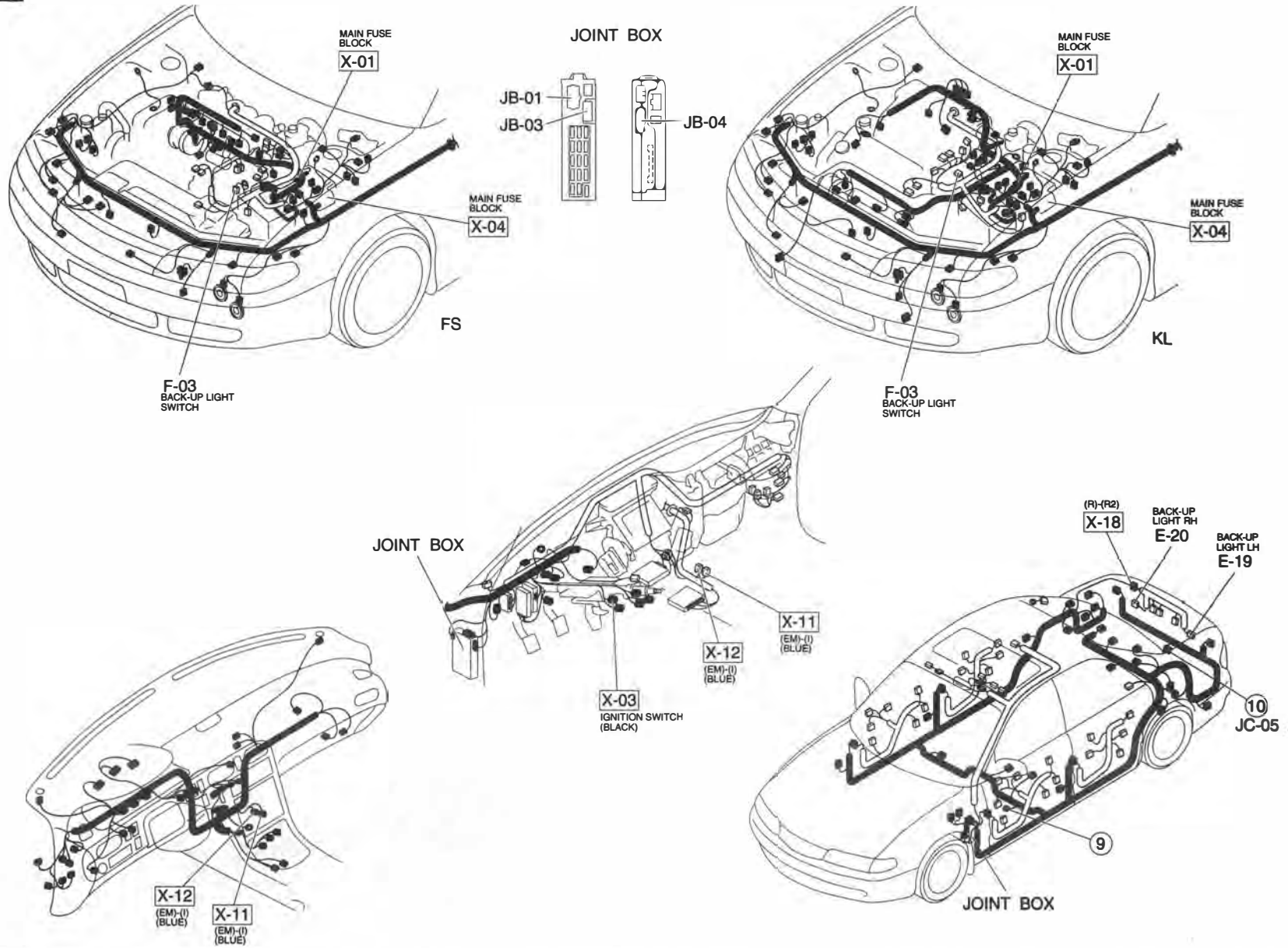

Z WIRING DIAGRAM

F-3 MX-6 ■ BACK-UP LIGHTS

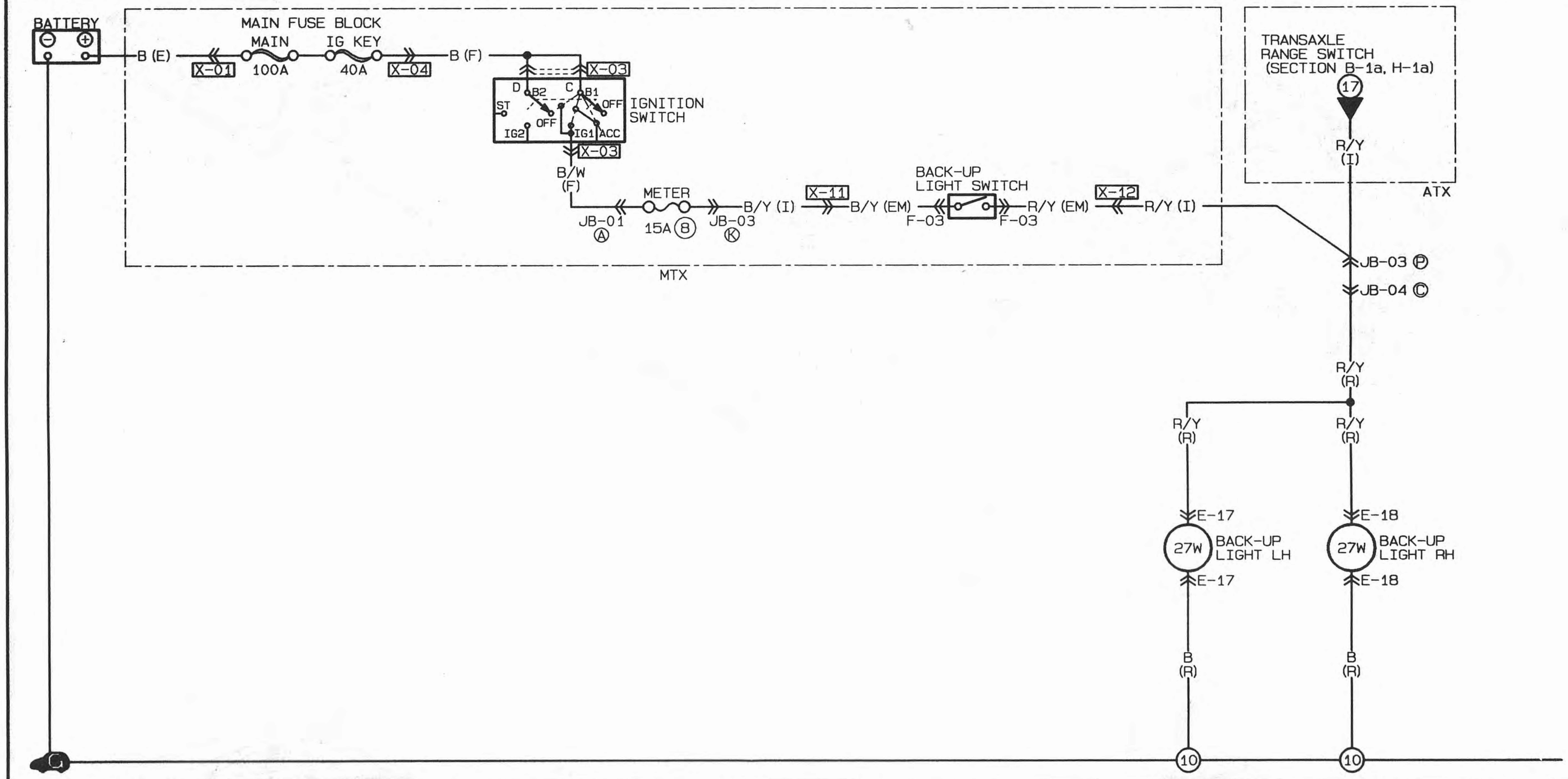

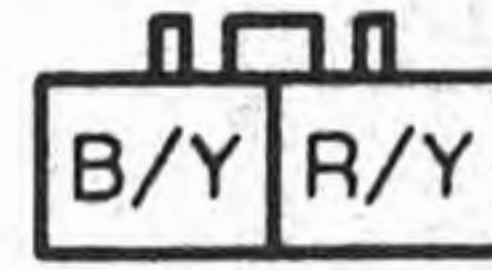
<p>F-03 BACK-UP LIGHT SWITCH (EM)</p> 	<p>E-17 BACK-UP LIGHT LH (R)</p> <table border="1" data-bbox="852 1404 1117 1510"> <tr> <td>G/B</td> <td></td> <td>*</td> </tr> <tr> <td>W/G</td> <td>R/Y</td> <td>O B</td> </tr> </table>	G/B		*	W/G	R/Y	O B	<p>E-18 BACK-UP LIGHT RH (R)</p> <table border="1" data-bbox="1528 1404 1793 1510"> <tr> <td>G/W</td> <td></td> <td>*</td> </tr> <tr> <td>W/G</td> <td>R/Y</td> <td>O B</td> </tr> </table>	G/W		*	W/G	R/Y	O B		
G/B		*														
W/G	R/Y	O B														
G/W		*														
W/G	R/Y	O B														

F-3

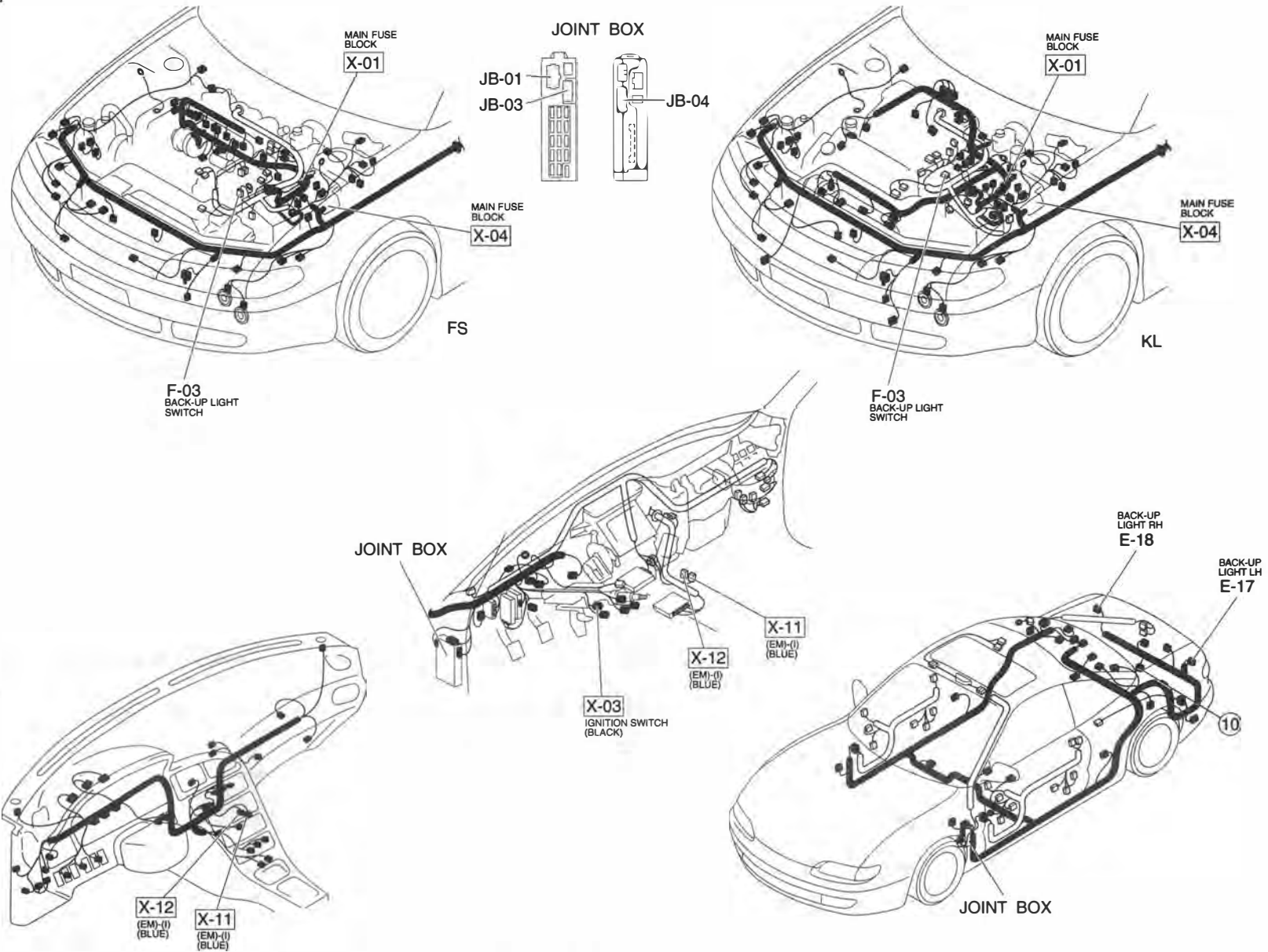

Z WIRING DIAGRAM

F-4 ■ HORNS ■ HIGH-MOUNT BRAKE LIGHT ■ BRAKE LIGHTS

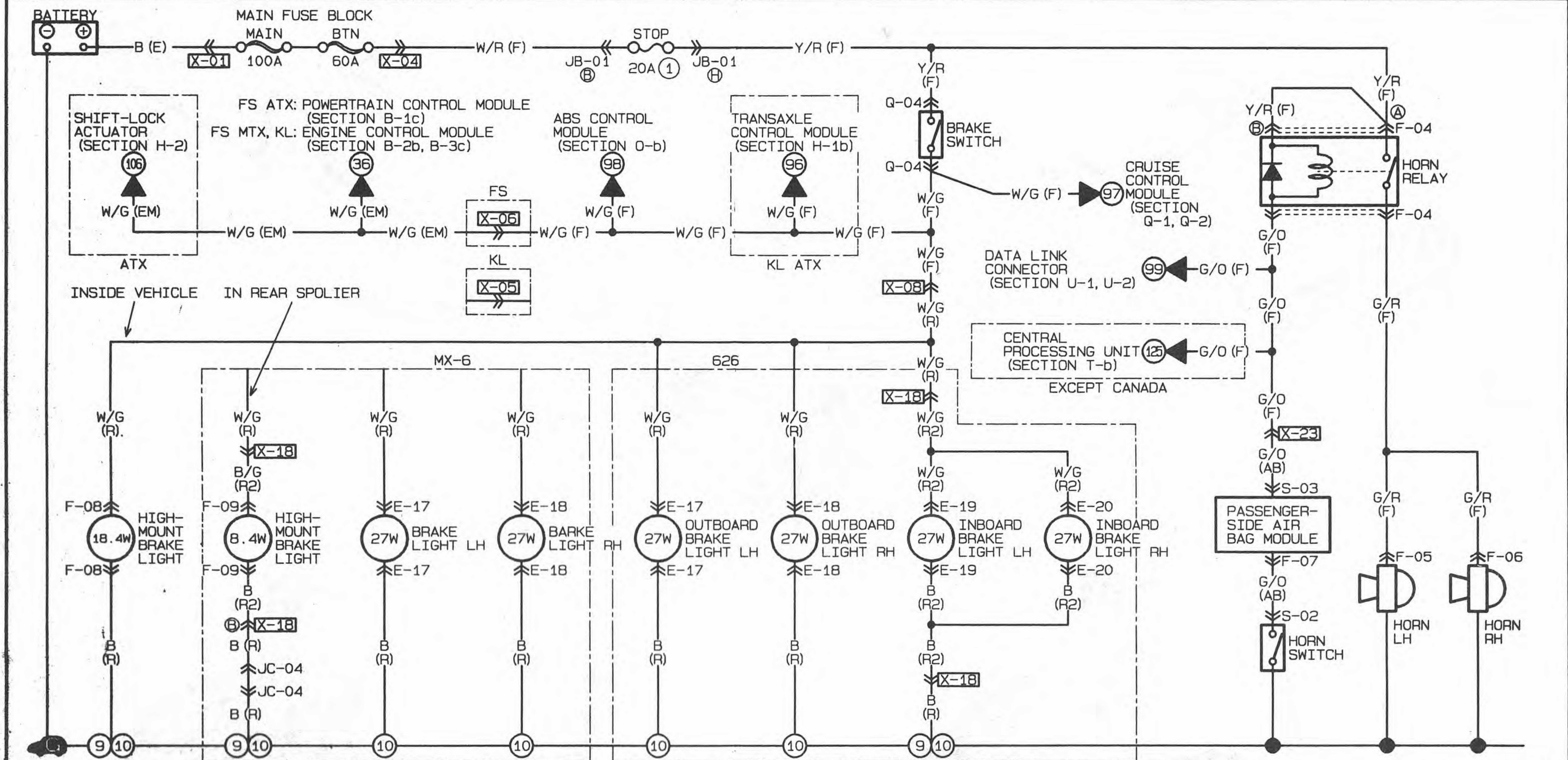

<p>F-04 HORN RELAY (F)</p>	<p>F-05 HORN LH (F)</p>	<p>F-06 HORN RH (F)</p>	<p>F-07 PASSENGER-SIDE AIR BAG MODULE (AB)</p>	<p>F-08 HIGH-MOUNT BRAKE LIGHT (R)</p>	<p>S-02 HORN SWITCH (AB)</p>	<p>S-03 PASSENGER-SIDE AIR BAG MODULE (AB)</p>
<p>F-09 HIGH-MOUNT BRAKE LIGHT (R2)</p>	<p>E-17 OUTBOARD BRAKE LIGHT LH (R)</p>	<p>E-17 BRAKE LIGHT LH (R)</p>	<p>E-18 OUTBOARD BRAKE LIGHT RH (R)</p>	<p>E-18 BRAKE LIGHT RH (R)</p>		
<p>E-19 INBOARD BRAKE LIGHT LH (R2)</p>	<p>E-20 INBOARD BRAKE LIGHT RH (R2)</p>	<p>Q-04 BRAKE SWITCH (F)</p>				

F-4

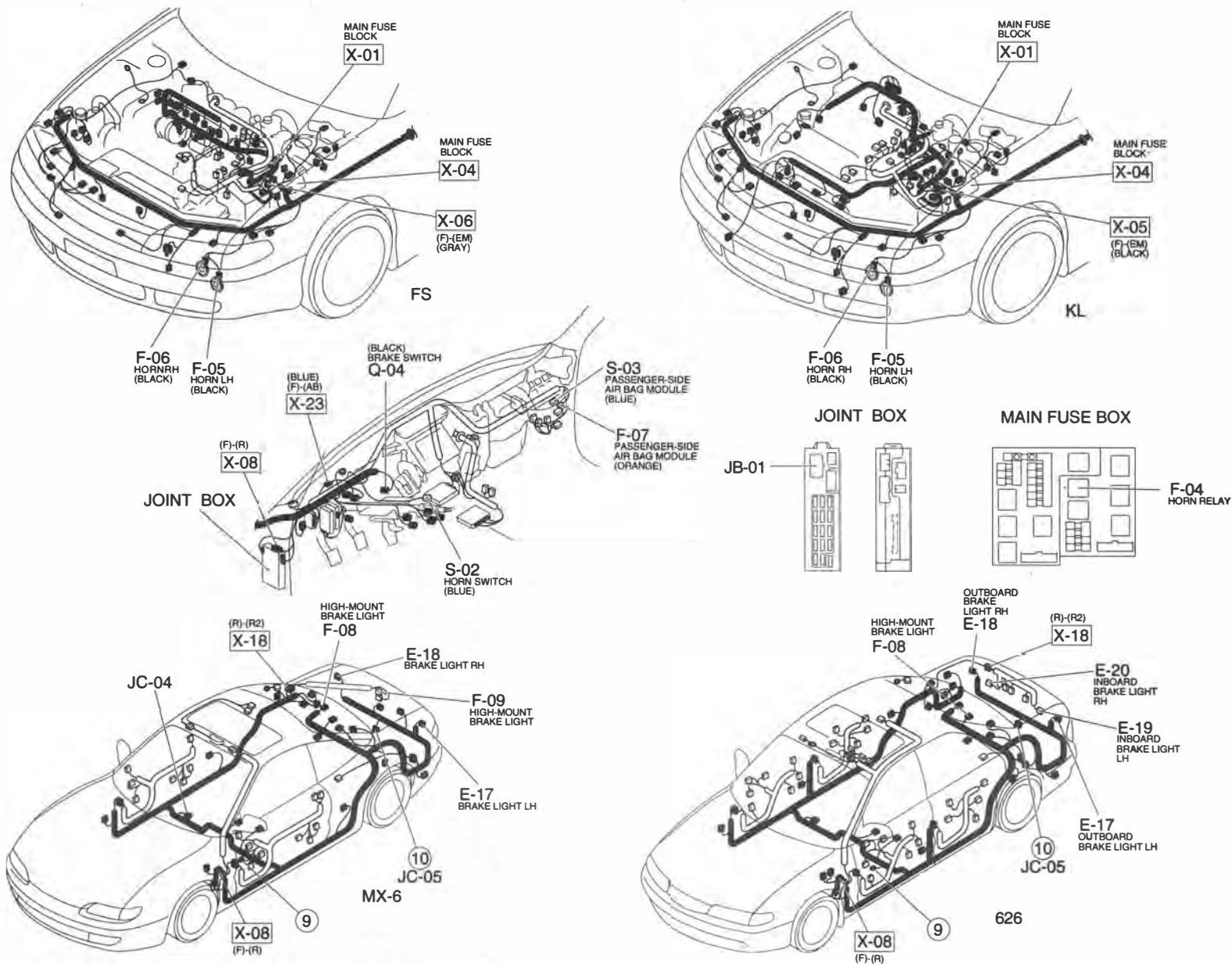

G-1a HEATER AND AIR CONDITIONER (1/2)

•...MX-6

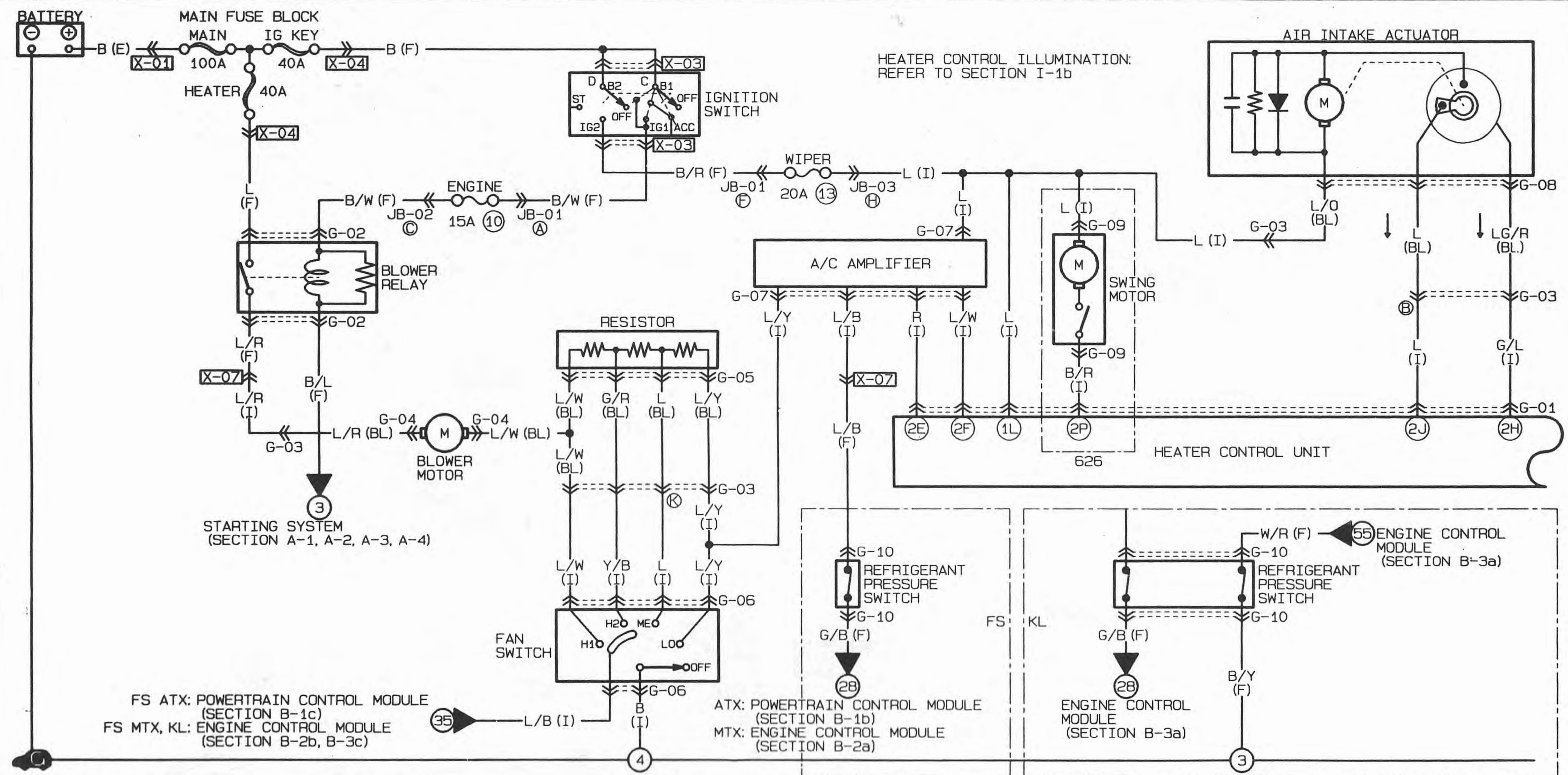

<p>G-01 HEATER CONTROL UNIT (I)</p> <table border="1"> <tr> <td>1K</td><td>1I</td><td>1C</td><td>1A</td><td>20</td><td>2M</td><td>2K</td><td>2E</td><td>2C</td><td>2A</td> </tr> <tr> <td>*</td><td>Y/G</td><td>X</td><td>P</td><td>G/W</td><td>W/G</td><td>W/L</td><td>Y/W</td><td>X</td><td>R</td><td>W/B</td><td>W</td> </tr> <tr> <td>L</td><td>B</td><td>Y/B</td><td>G/Y</td><td>G</td><td>BR</td><td>B/R</td><td>W/Y</td><td>Y</td><td>L</td><td>G/L</td><td>L/W</td><td>O</td><td>GY</td> </tr> <tr> <td>1L</td><td>1J</td><td>1H</td><td>1F</td><td>1D</td><td>1B</td><td>2P</td><td>2N</td><td>2L</td><td>2J</td><td>2H</td><td>2F</td><td>2D</td><td>2B</td> </tr> </table>	1K	1I	1C	1A	20	2M	2K	2E	2C	2A	*	Y/G	X	P	G/W	W/G	W/L	Y/W	X	R	W/B	W	L	B	Y/B	G/Y	G	BR	B/R	W/Y	Y	L	G/L	L/W	O	GY	1L	1J	1H	1F	1D	1B	2P	2N	2L	2J	2H	2F	2D	2B	<p>G-02 BLOWER RELAY (F)</p> <table border="1"> <tr> <td>B/W</td><td>*</td><td>B/L</td> </tr> <tr> <td>L</td><td>X</td><td>L/R</td> </tr> </table>	B/W	*	B/L	L	X	L/R	<p>G-03 INSTRUMENT PANEL (I) - BLOWER MOTOR (BL)</p> <table border="1"> <tr> <td>L/Y</td><td>*</td><td>*</td><td>X</td><td>*</td><td>G/L</td><td>L</td><td>L/O</td><td>LG/R</td><td>*</td><td>X</td><td>*</td><td>*</td><td>L/Y</td> </tr> <tr> <td>L</td><td>Y/B</td><td>L/W</td><td>L/R</td><td>L</td><td>L</td><td>L</td><td>L</td><td>L</td><td>L</td><td>L</td><td>L</td><td>L</td><td>L</td> </tr> <tr> <td>Ⓚ</td><td></td><td></td><td></td><td></td><td></td><td></td><td></td><td></td><td></td><td></td><td></td><td></td><td>Ⓚ</td> </tr> </table>	L/Y	*	*	X	*	G/L	L	L/O	LG/R	*	X	*	*	L/Y	L	Y/B	L/W	L/R	L	L	L	L	L	L	L	L	L	L	Ⓚ													Ⓚ
1K	1I	1C	1A	20	2M	2K	2E	2C	2A																																																																																											
*	Y/G	X	P	G/W	W/G	W/L	Y/W	X	R	W/B	W																																																																																									
L	B	Y/B	G/Y	G	BR	B/R	W/Y	Y	L	G/L	L/W	O	GY																																																																																							
1L	1J	1H	1F	1D	1B	2P	2N	2L	2J	2H	2F	2D	2B																																																																																							
B/W	*	B/L																																																																																																		
L	X	L/R																																																																																																		
L/Y	*	*	X	*	G/L	L	L/O	LG/R	*	X	*	*	L/Y																																																																																							
L	Y/B	L/W	L/R	L	L	L	L	L	L	L	L	L	L																																																																																							
Ⓚ													Ⓚ																																																																																							
<p>G-04 BLOWER MOTOR (BL)</p> <table border="1"> <tr> <td>L/W</td><td>L/R</td> </tr> </table>	L/W	L/R	<p>G-05 RESISTOR (BL)</p> <table border="1"> <tr> <td>L</td><td>L/Y</td> </tr> <tr> <td>L/W</td><td>G/R</td> </tr> </table>	L	L/Y	L/W	G/R	<p>G-06 FAN SWITCH (I)</p> <table border="1"> <tr> <td>L/Y</td><td>L</td><td>Y/B</td> </tr> <tr> <td>B</td><td>L/B</td><td>L/W</td> </tr> </table>	L/Y	L	Y/B	B	L/B	L/W	<p>G-07 A/C AMPLIFIER (I)</p> <table border="1"> <tr> <td>*</td><td>L/Y</td><td>R</td><td>L/W</td><td>L/B</td><td>L</td> </tr> </table>	*	L/Y	R	L/W	L/B	L	<p>G-08 AIR INTAKE ACTUATOR (BL)</p> <table border="1"> <tr> <td>LG/R</td><td>L</td><td>L/O</td> </tr> </table>	LG/R	L	L/O	<p>G-09 SWING MOTOR (I)</p> <table border="1"> <tr> <td>L</td><td>B/R</td> </tr> </table>	L	B/R																																																																								
L/W	L/R																																																																																																			
L	L/Y																																																																																																			
L/W	G/R																																																																																																			
L/Y	L	Y/B																																																																																																		
B	L/B	L/W																																																																																																		
*	L/Y	R	L/W	L/B	L																																																																																															
LG/R	L	L/O																																																																																																		
L	B/R																																																																																																			
<p>G-10 REFRIGERANT PRESSURE SWITCH (F)</p> <table border="1"> <tr> <td>FS</td><td>G/B</td><td>L/B</td> </tr> </table>	FS	G/B	L/B	<p>KL</p> <table border="1"> <tr> <td>G/B</td><td>W/R</td> </tr> <tr> <td>L/B</td><td></td> </tr> </table>	G/B	W/R	L/B																																																																																													
FS	G/B	L/B																																																																																																		
G/B	W/R																																																																																																			
L/B																																																																																																				

G-1a

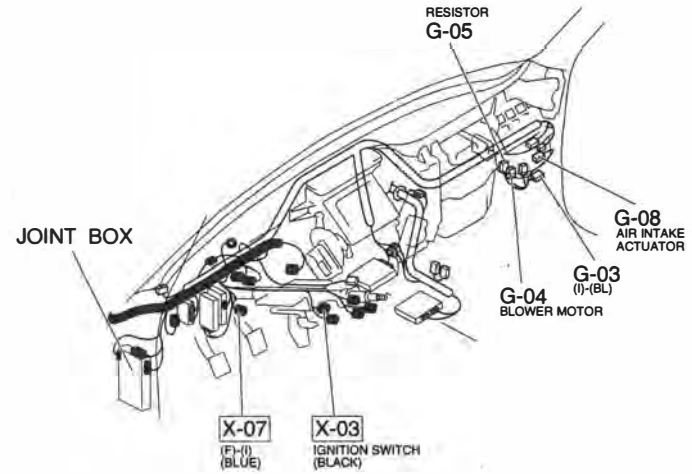
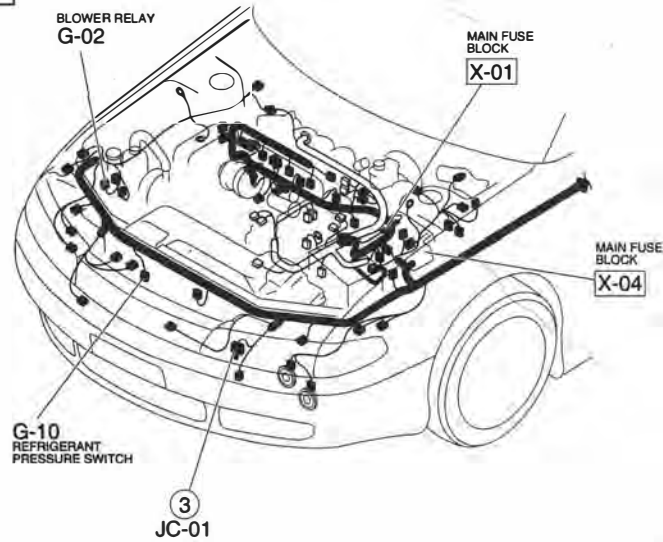

JOINT BOX

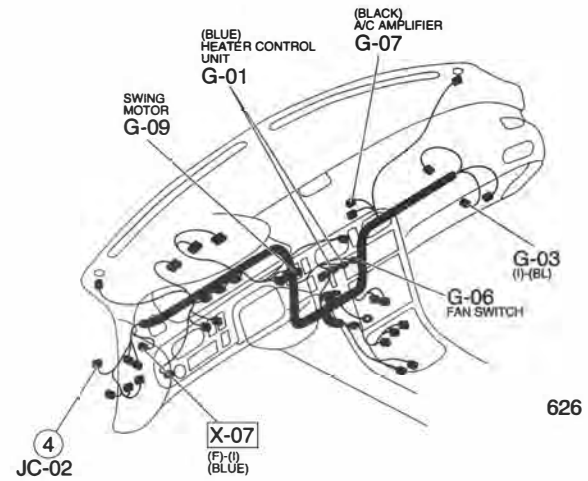
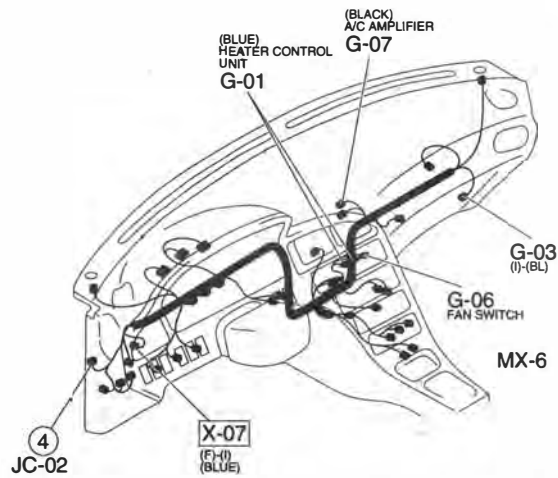
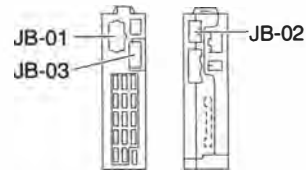

626

G-1b ■ HEATER AND AIR CONDITIONER (2/2)

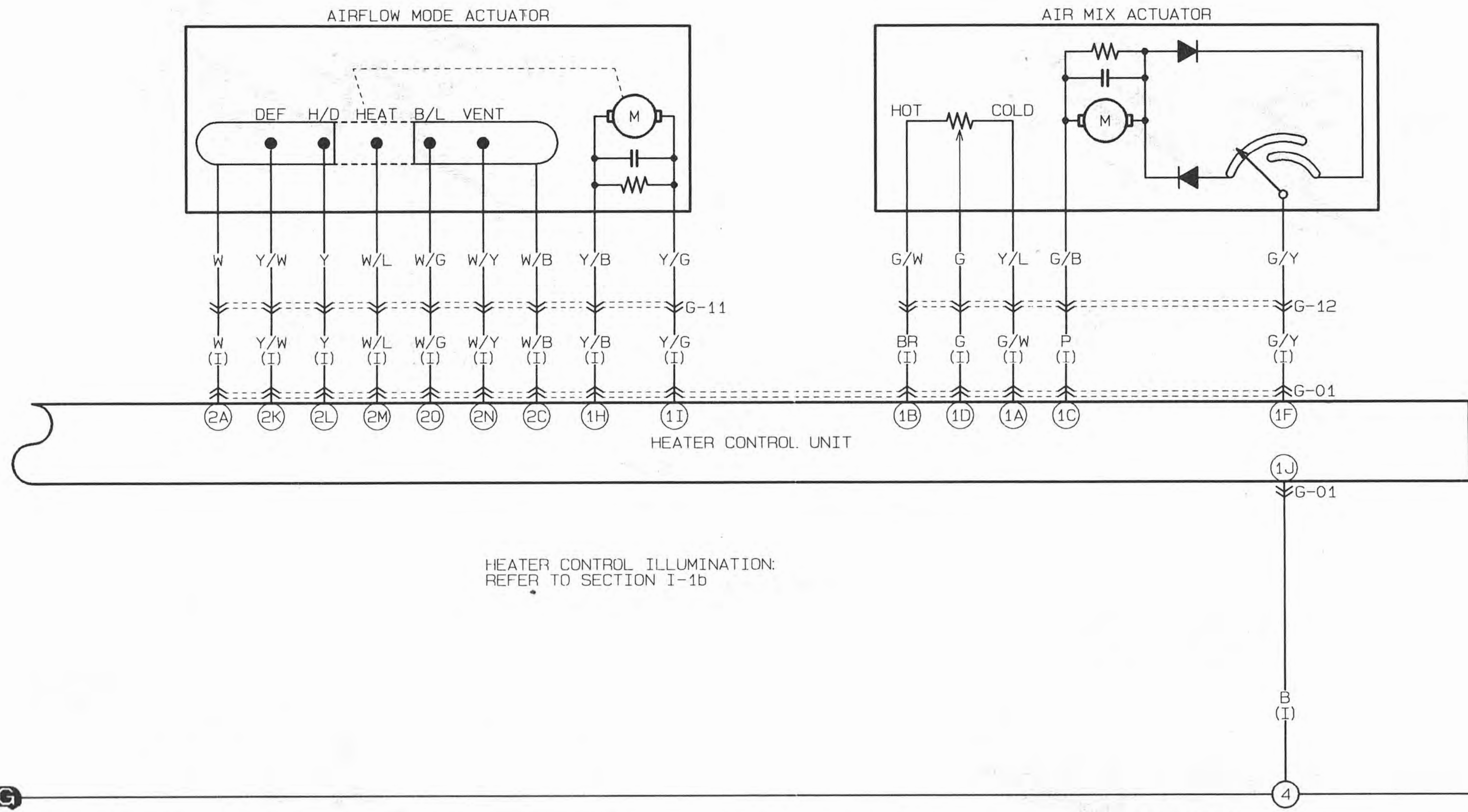

G-01 HEATER CONTROL UNIT (I)

1K	1I	1C	1A	20	2M	2K	2E	2C	2A
*	Y/G	P	G/W	W/G	W/L	Y/W	R	W/B	W
L	B	Y/B	G/Y	B/R	W/Y	Y	L	G/L	L/W
1L	1J	1H	1F	2P	2N	2L	2J	2H	2F
									2D
									2B

G-11 INSTRUMENT PANEL (I) -AIRFLOW MODE ACTUATOR

W	Y/B	W/G	W/B	W/B	W/G	Y/B	W
*	Y/G	Y/W	Y	W/L	W/Y	Y	Y/W

G-12 INSTRUMENT PANEL (I) -AIR MIX ACTUATOR

P	BR	G/W	G/B
G/Y	*	G/W	G

G-1b

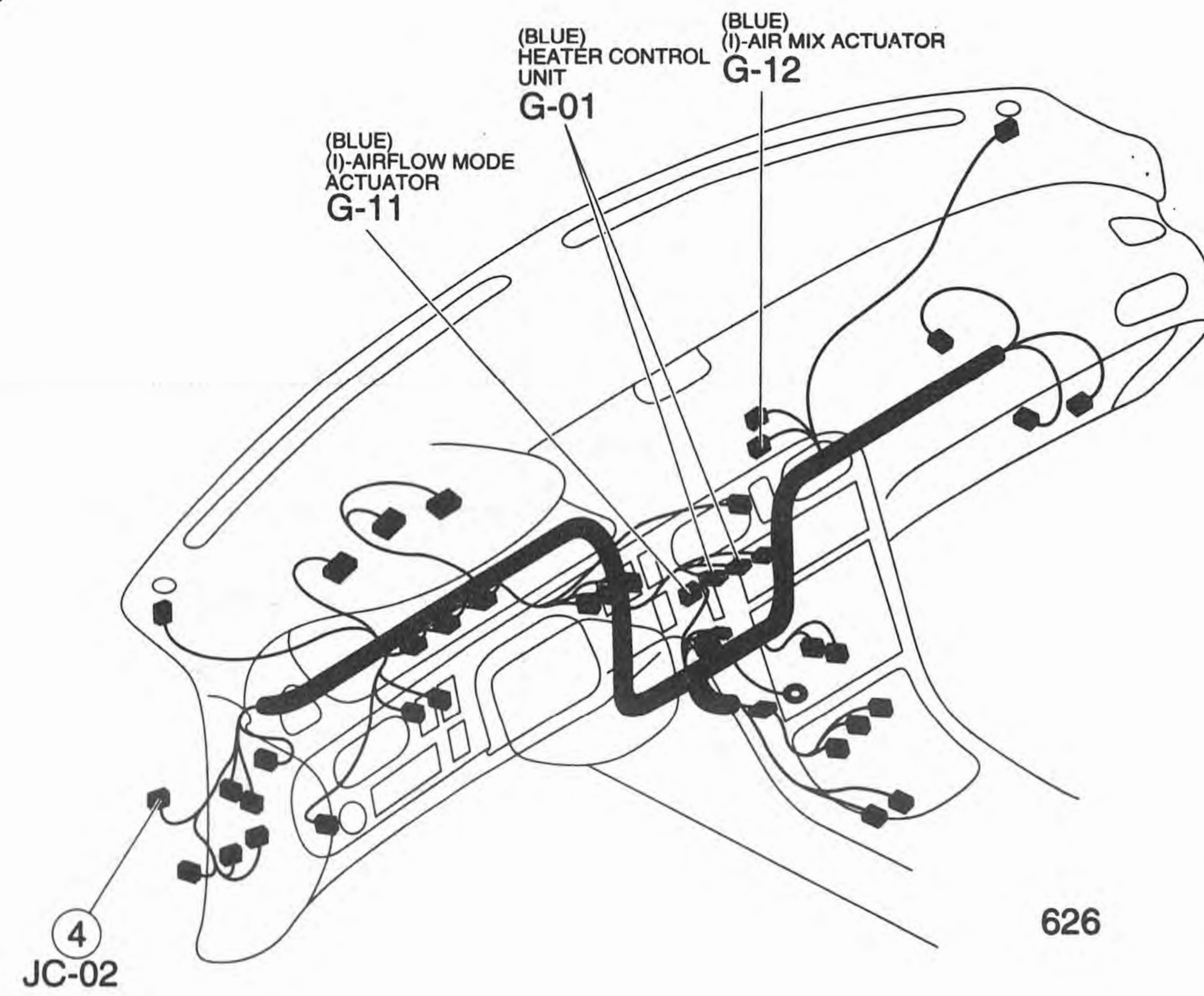
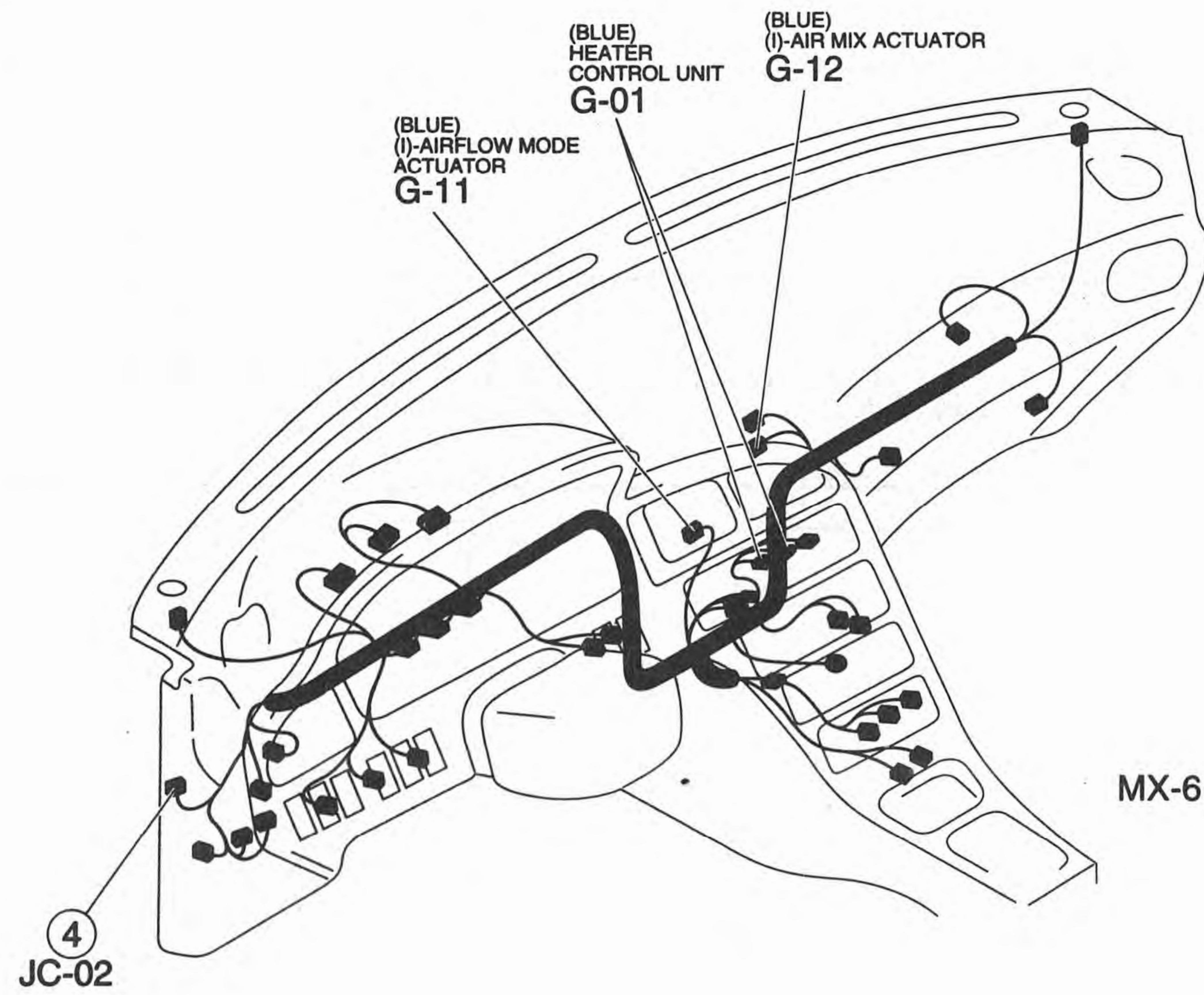

G-2 FS ■ CONDENSER FAN SYSTEM

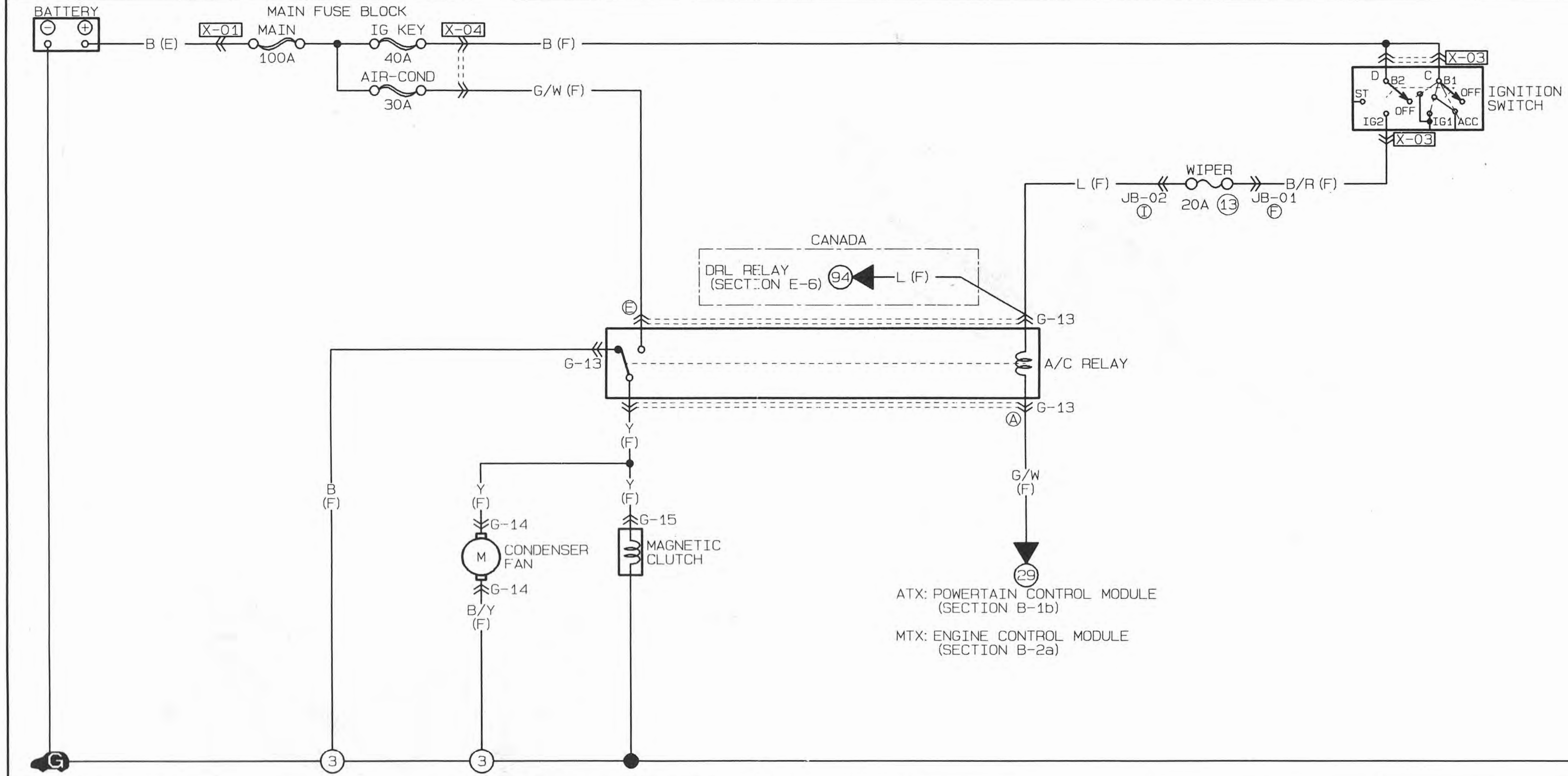

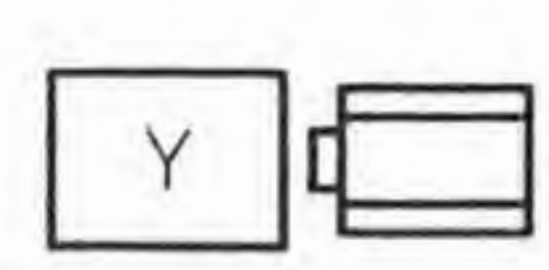
<p>G-13 A/C RELAY (F)</p> <table border="1"> <tr> <td colspan="2">FEDERAL AND CALIFORNIA</td> <td colspan="2">CANADA</td> </tr> <tr> <td>ⓔ</td> <td>ⓐ</td> <td>ⓔ</td> <td>ⓐ</td> </tr> <tr> <td>G/W</td> <td>Y</td> <td>G/W</td> <td>Y</td> </tr> <tr> <td>B</td> <td>L</td> <td>B</td> <td>L</td> </tr> <tr> <td></td> <td>*</td> <td></td> <td>*</td> </tr> </table>	FEDERAL AND CALIFORNIA		CANADA		ⓔ	ⓐ	ⓔ	ⓐ	G/W	Y	G/W	Y	B	L	B	L		*		*	<p>G-14 CONDENSER FAN (F)</p> 	<p>G-15 MAGNETIC CLUTCH (F)</p> 			
FEDERAL AND CALIFORNIA		CANADA																							
ⓔ	ⓐ	ⓔ	ⓐ																						
G/W	Y	G/W	Y																						
B	L	B	L																						
	*		*																						

G-2

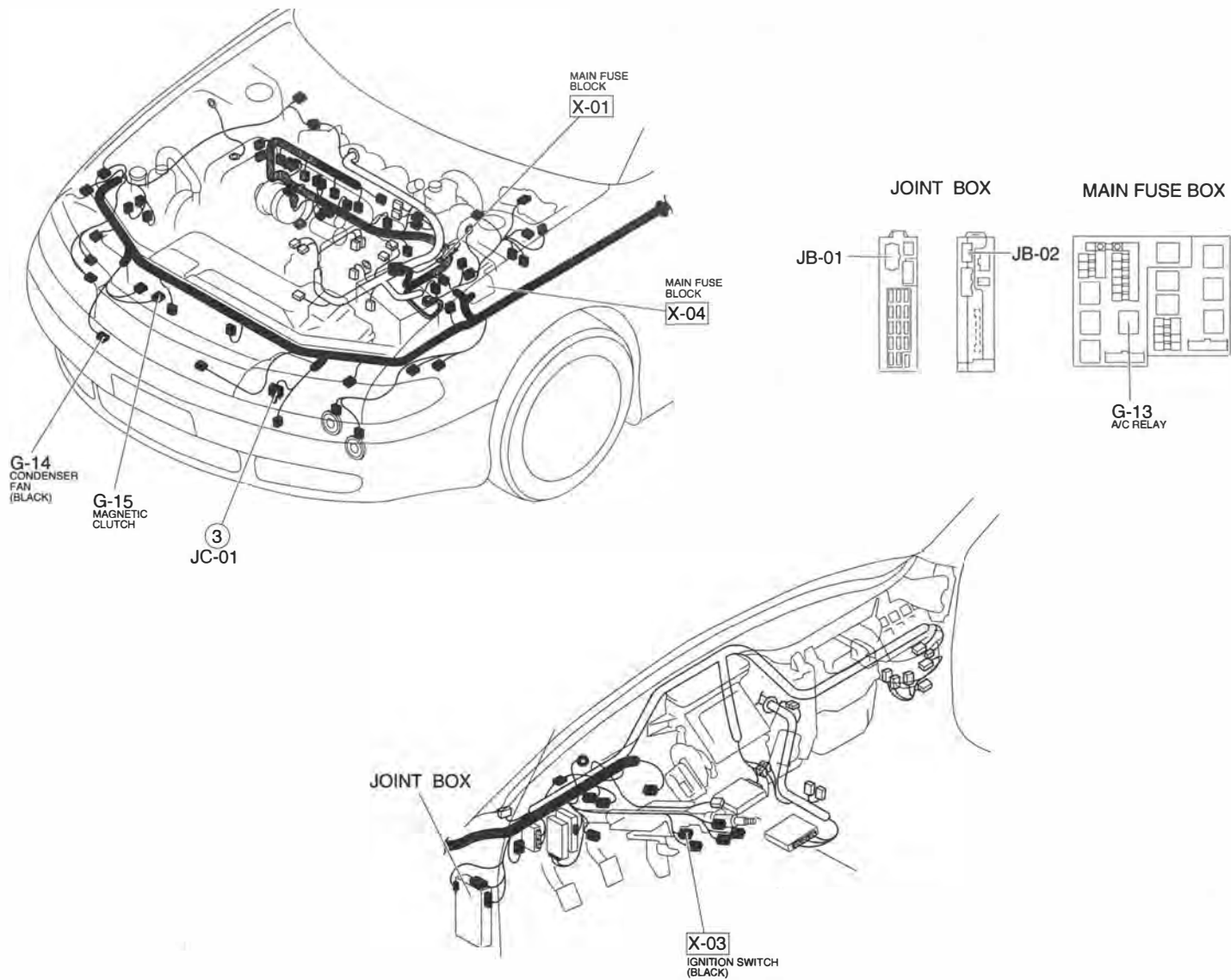

Z WIRING DIAGRAM

G-3 KL ■ CONDENSER FAN SYSTEM

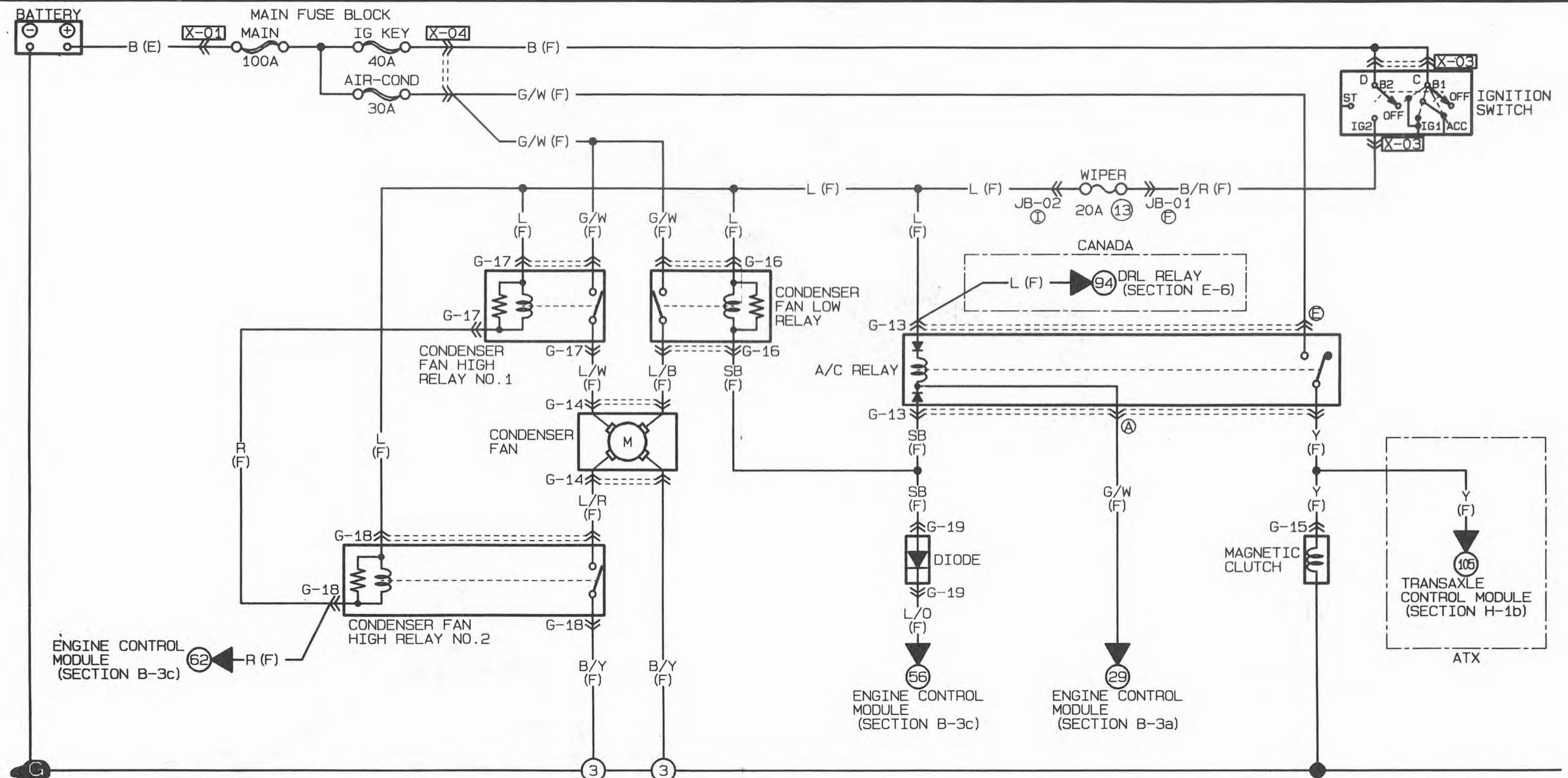

<p>G-13 A/C RELAY (F)</p> <table border="1"> <tr> <td>ⓔ</td> <td>ⓐ</td> </tr> <tr> <td>G/W</td> <td>G/W</td> </tr> <tr> <td>Y</td> <td>L</td> </tr> <tr> <td>SB</td> <td>SB</td> </tr> </table> <p>FEDERAL AND CALIFORNIA</p> <table border="1"> <tr> <td>ⓔ</td> <td>ⓐ</td> </tr> <tr> <td>G/W</td> <td>G/W</td> </tr> <tr> <td>Y</td> <td>L</td> </tr> <tr> <td>SB</td> <td>SB</td> </tr> </table> <p>CANADA</p>	ⓔ	ⓐ	G/W	G/W	Y	L	SB	SB	ⓔ	ⓐ	G/W	G/W	Y	L	SB	SB	<p>G-14 CONDENSER FAN (F)</p> <table border="1"> <tr> <td>L/W</td> <td>L/B</td> </tr> <tr> <td>L/R</td> <td>B/Y</td> </tr> </table>	L/W	L/B	L/R	B/Y	<p>G-15 MAGNETIC CLUTCH (F)</p> <table border="1"> <tr> <td>Y</td> </tr> </table>	Y	<p>G-16 CONDENSER FAN LOW RELAY (F)</p> <table border="1"> <tr> <td>G/W</td> <td>L</td> </tr> <tr> <td>L/B</td> <td>SB</td> </tr> </table>	G/W	L	L/B	SB	<p>G-17 CONDENSER FAN HIGH RELAY NO. 1 (F)</p> <table border="1"> <tr> <td>G/W</td> <td>L</td> </tr> <tr> <td>L/W</td> <td>R</td> </tr> </table>	G/W	L	L/W	R	<p>G-18 CONDENSER FAN HIGH RELAY NO. 2 (F)</p> <table border="1"> <tr> <td>L/R</td> <td>L</td> </tr> <tr> <td>B/Y</td> <td>R</td> </tr> </table>	L/R	L	B/Y	R
ⓔ	ⓐ																																					
G/W	G/W																																					
Y	L																																					
SB	SB																																					
ⓔ	ⓐ																																					
G/W	G/W																																					
Y	L																																					
SB	SB																																					
L/W	L/B																																					
L/R	B/Y																																					
Y																																						
G/W	L																																					
L/B	SB																																					
G/W	L																																					
L/W	R																																					
L/R	L																																					
B/Y	R																																					
<p>G-19 DIODE (F)</p> <table border="1"> <tr> <td>SB</td> </tr> <tr> <td>L/O</td> </tr> </table>	SB	L/O																																				
SB																																						
L/O																																						

G-3

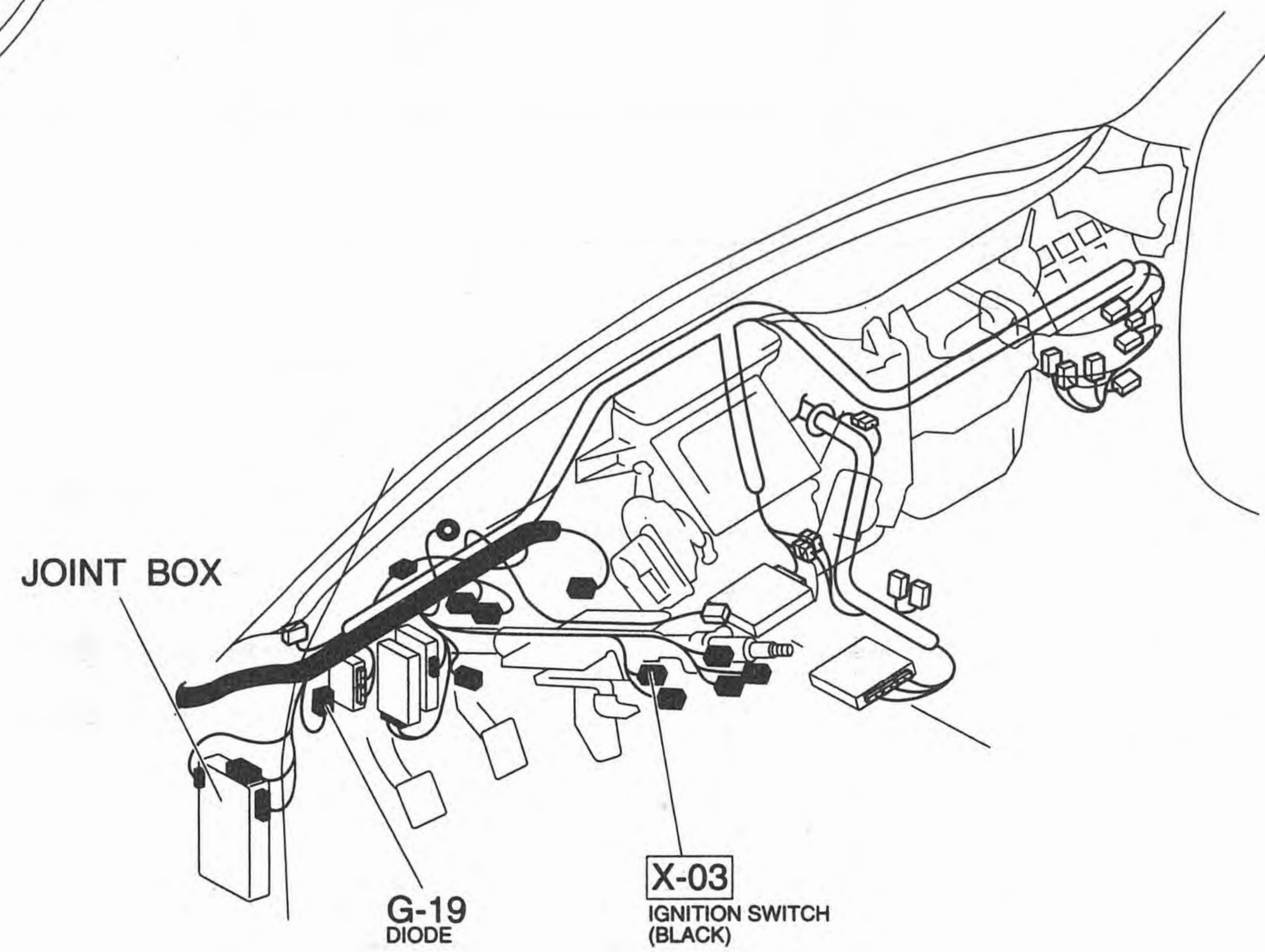
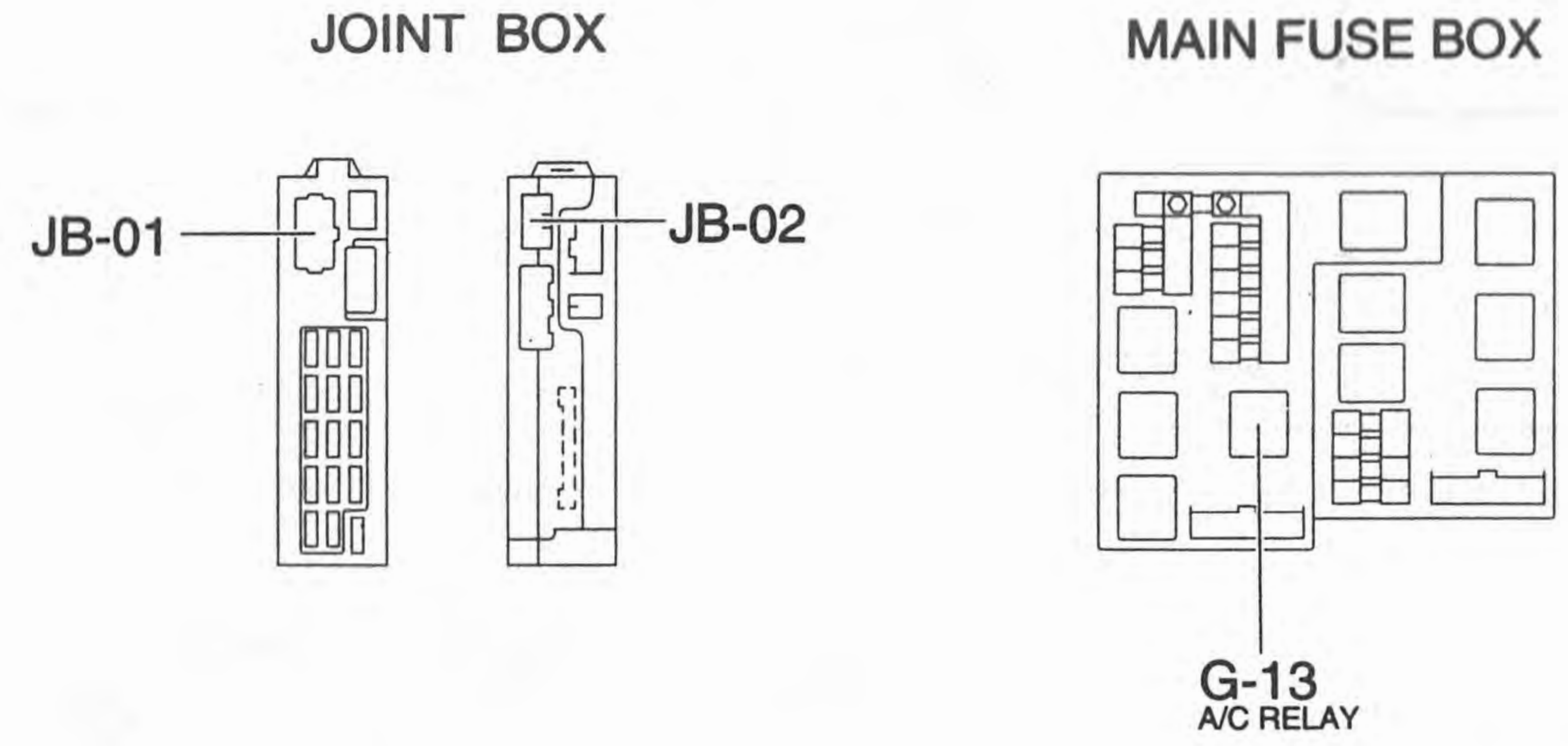
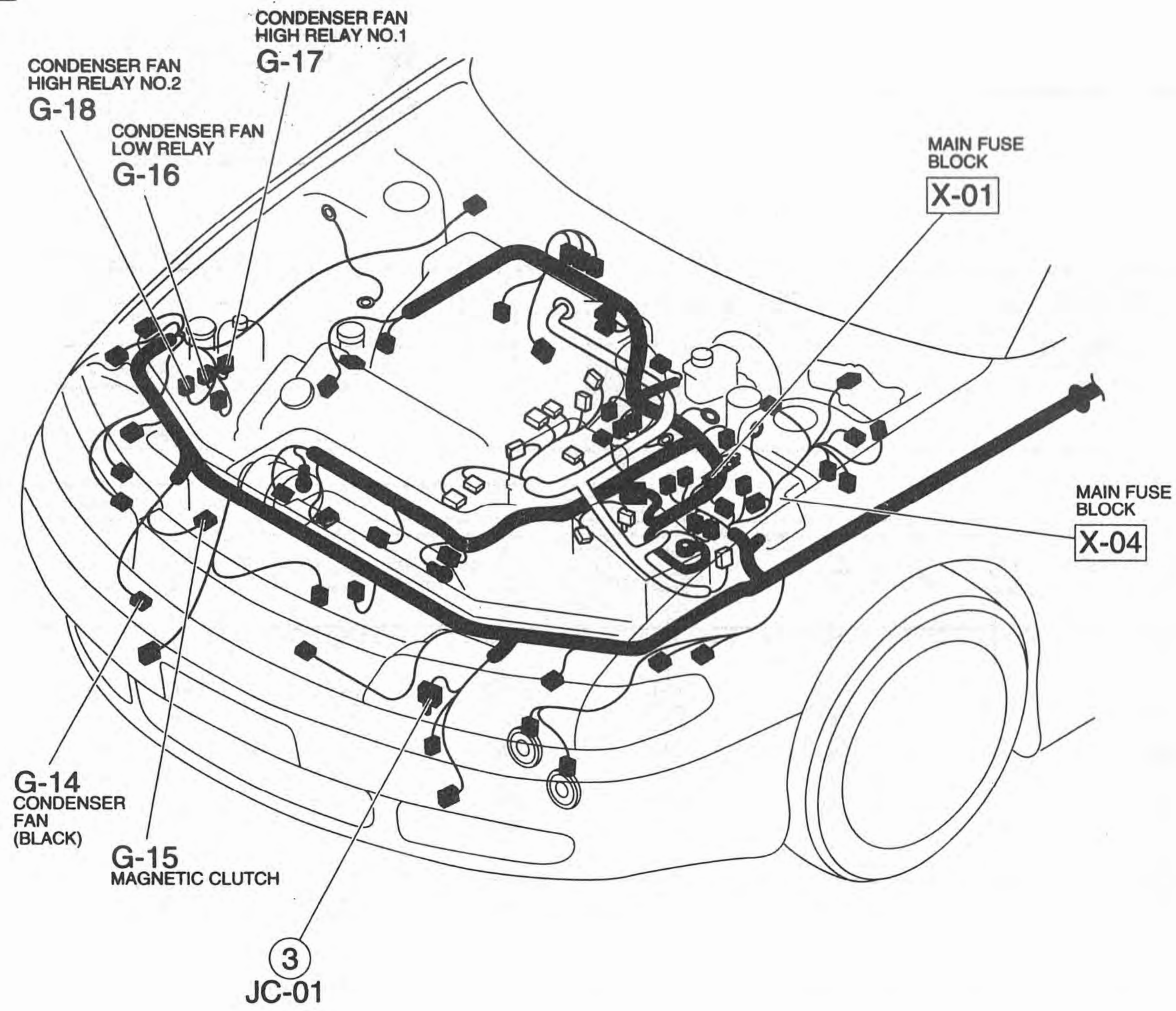

Z WIRING DIAGRAM

H-1a KL ■ EC-AT CONTROL SYSTEM (1/2)

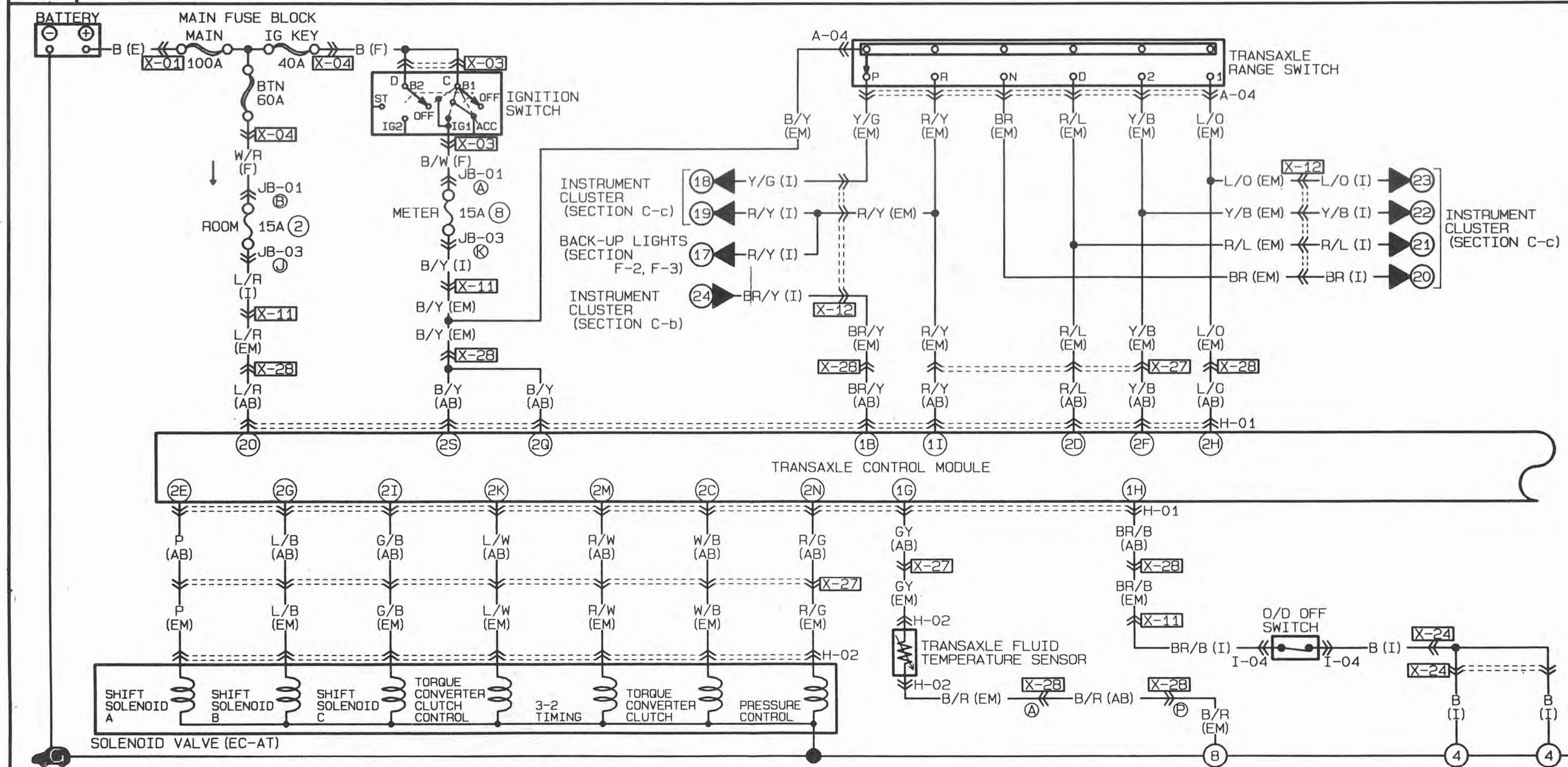

H-01 TRANSAXLE CONTROL MODULE (AB)

10	1M	1K	1I	1G	1E	1C	1A
BR	GY/R	Y/L	R/Y	GY	R/B	R	Y
G/R	LG	L	BR/W	BR/B	W/G	G/Y	BR/Y
1P	1N	1L	1J	1H	1F	1D	1B

2S	2Q	2O	2M	2K	2I	2G	2E	2C	2A
B/Y	B/Y	L/R	R/W	L/W	G/B	L/B	P	W/B	G/L
P/G	G/O	B/R	R/G	R	W	L/O	Y/B	R/L	G
2T	2R	2P	2N	2L	2J	2H	2F	2D	2B

H-02 SOLENOID VALVE (EC-AT) AND TRANSAXLE FLUID TEMPERATURE SENSOR (EM)

GY	R/G	R/W	G/B	P
B/R	*	W/B	L/W	L/B

A-04 TRANSAXLE RANGE SWITCH (EM)

B/Y	R/L	L/O	R/Y	Y/G
G	Y/B	BR	B/L	

I-04 O/D OFF SWITCH (I)

BR/B	O
B	GY

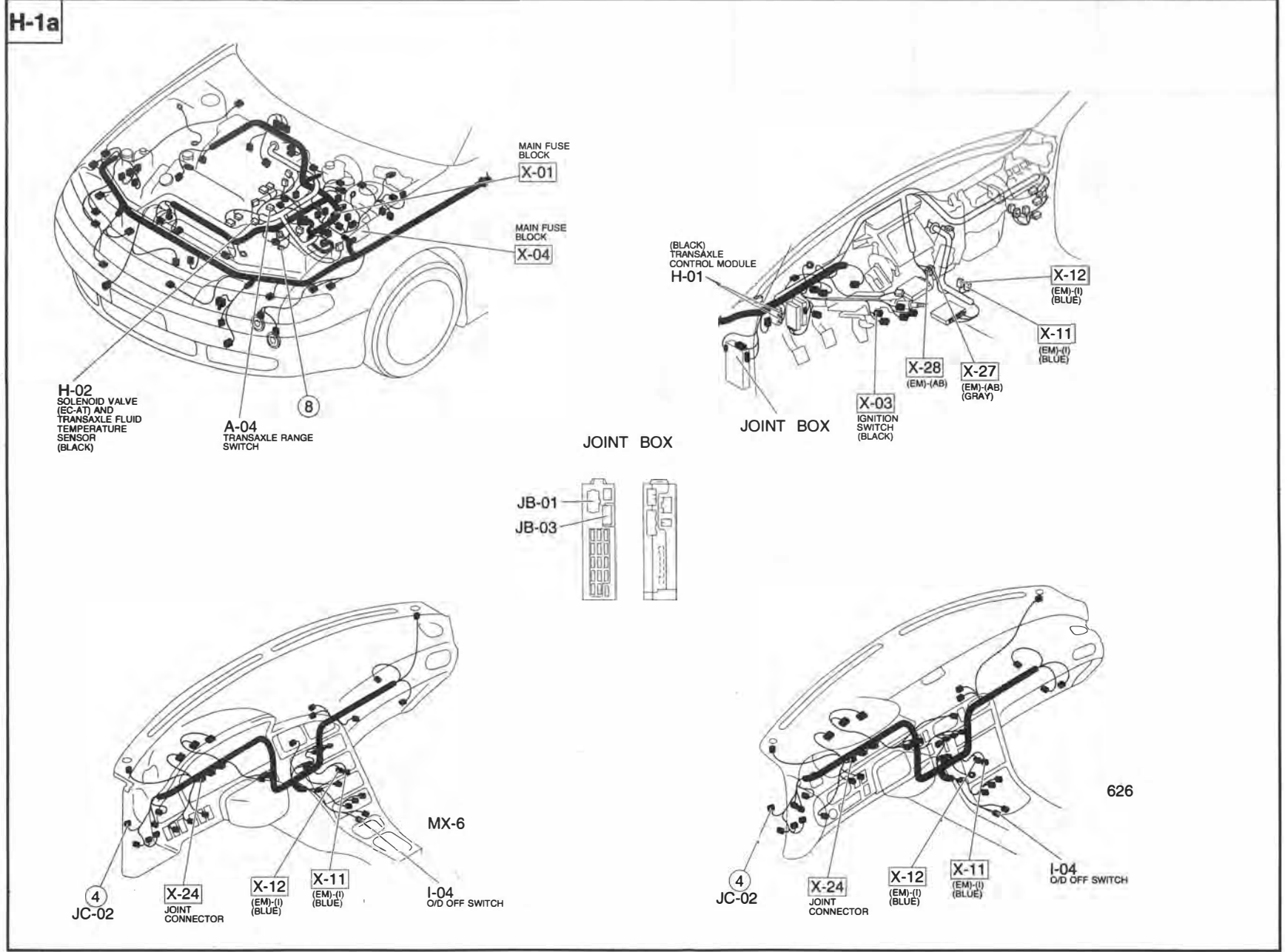

Z WIRING DIAGRAM

H-1b KL ■ EC-AT CONTROL SYSTEM (2/2)

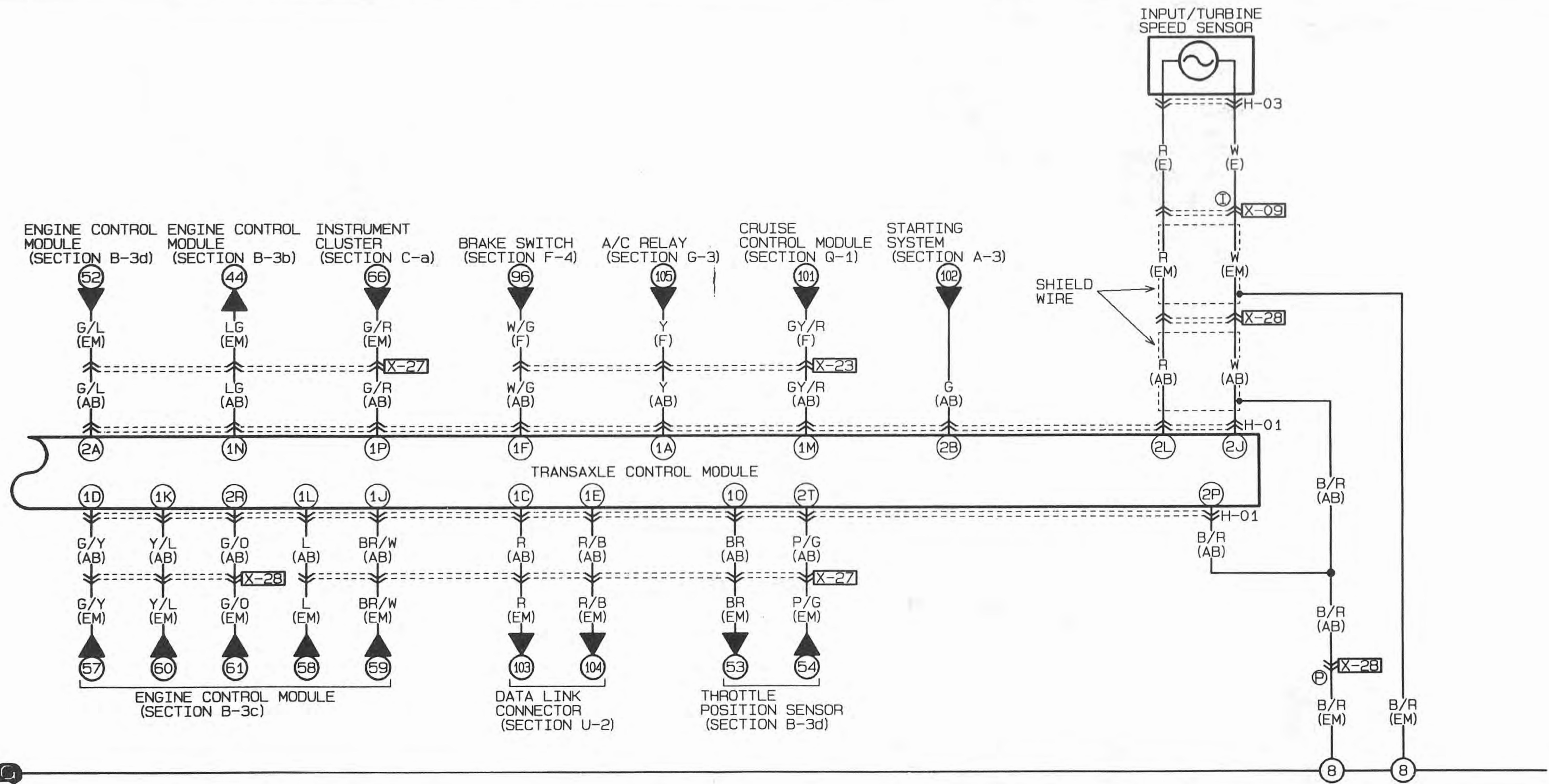

H-01 TRANSAXLE CONTROL MODULE (AB)

10	1M	1K	1I	1G	1E	1C	1A
BR	GY/R	Y/L	R/Y	GY	R/B	R	Y
G/R	LG	L	BR/W	BR/B	W/G	G/Y	BR/Y
1P	1N	1L	1J	1H	1F	1D	1B

2S	2Q	2O	2M	2K	2I	2G	2E	2C	2A
B/Y	B/Y	L/R	R/W	L/W	G/B	L/B	P	W/B	G/L
P/G	G/O	B/R	R/G	R	W	L/O	Y/B	R/L	G
2T	2R	2P	2N	2L	2J	2H	2F	2D	2B

H-03 INPUT/TURBINE SPEED SENSOR (E)

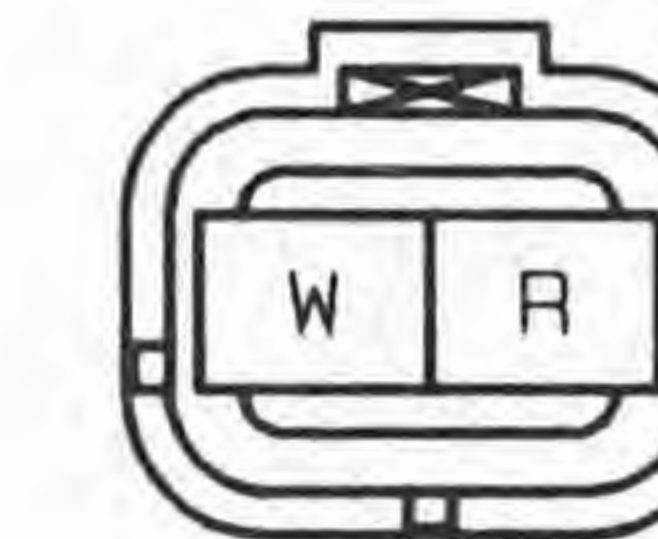

H-1b

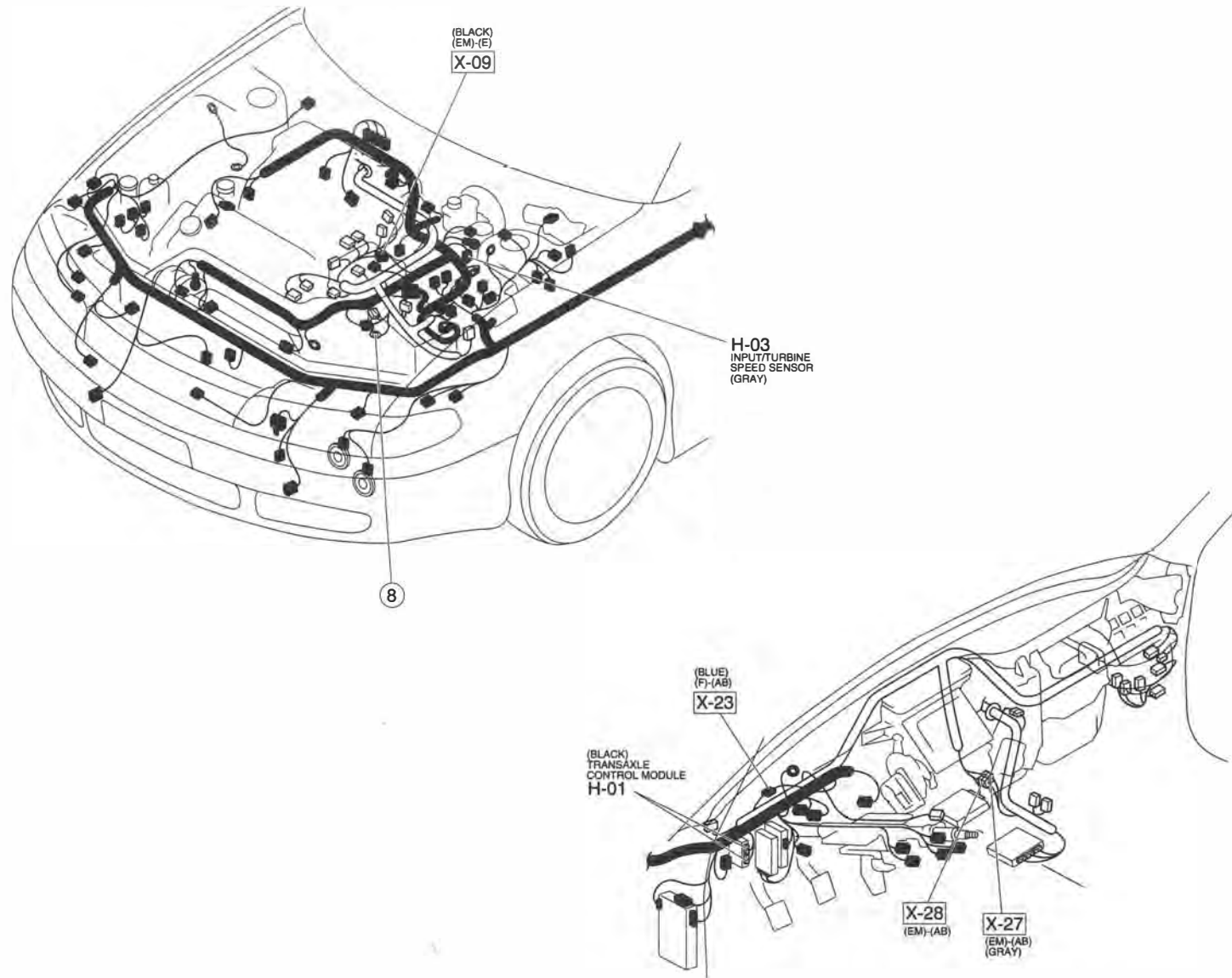

Z WIRING DIAGRAM

H-2 ■ SHIFT-LOCK SYSTEM



H-04 SHIFT-LOCK ACTUATOR (I)

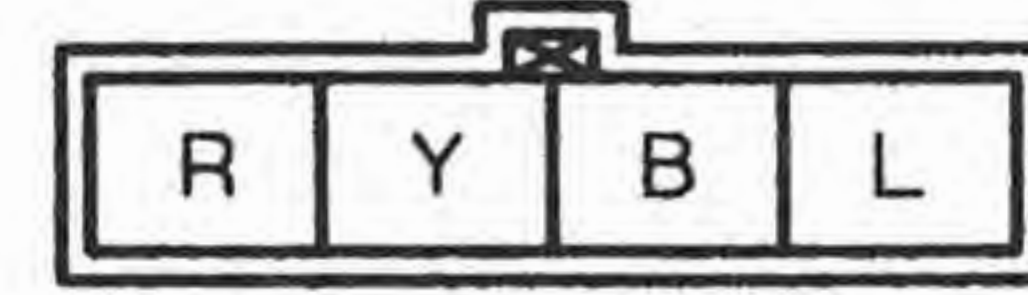
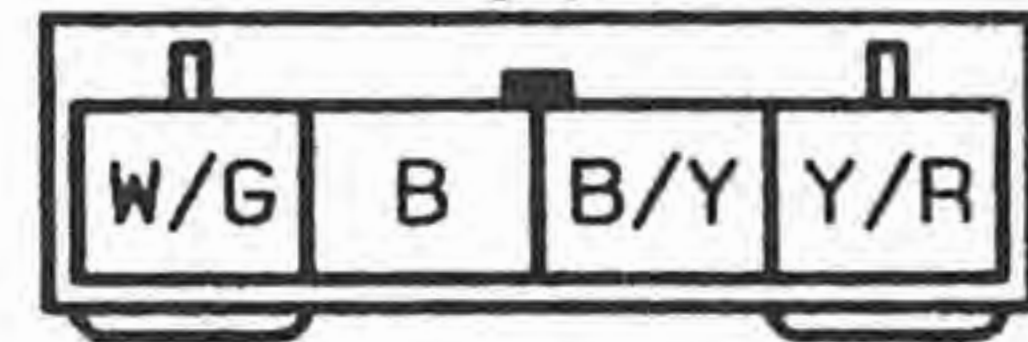

H-2

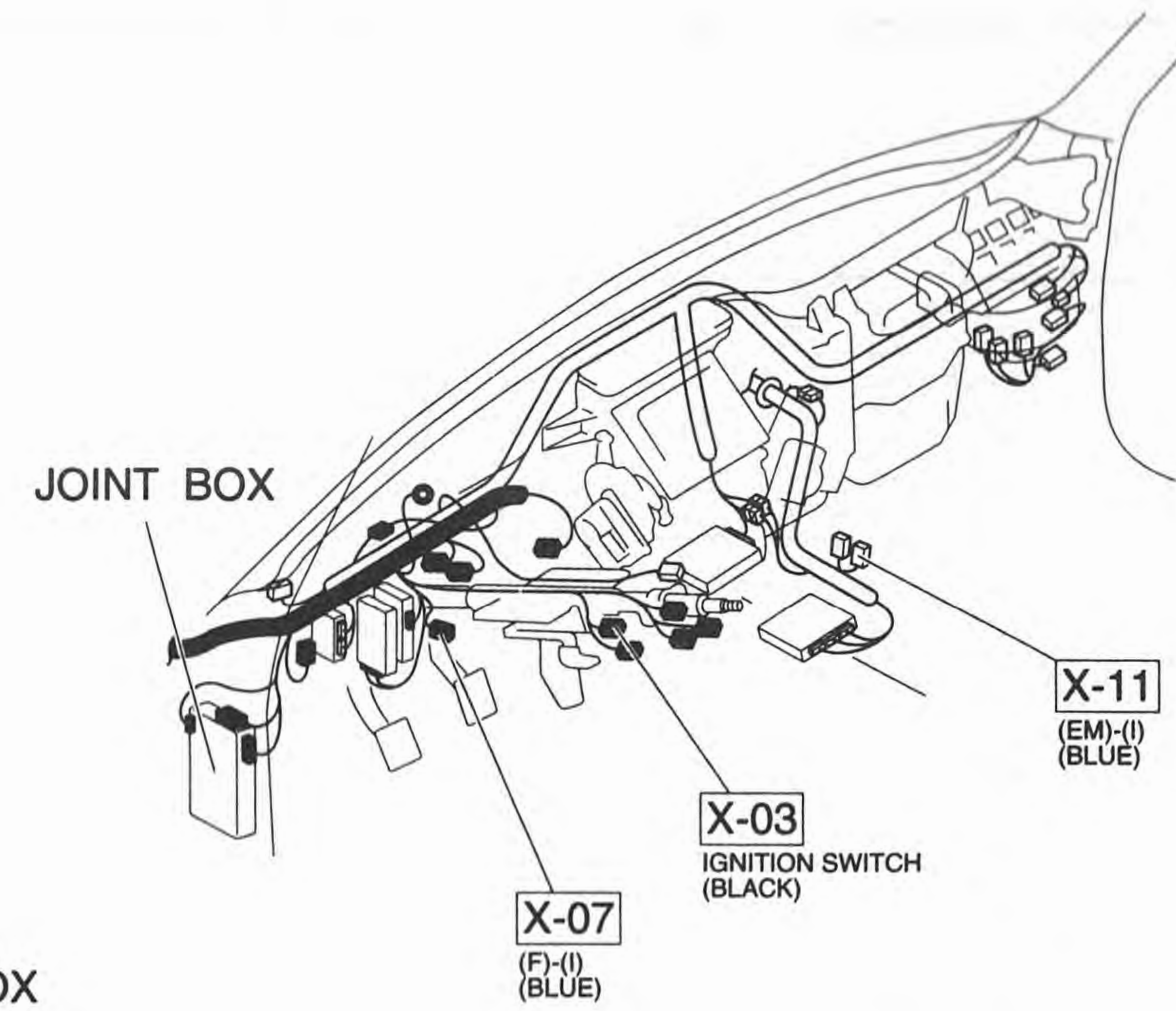
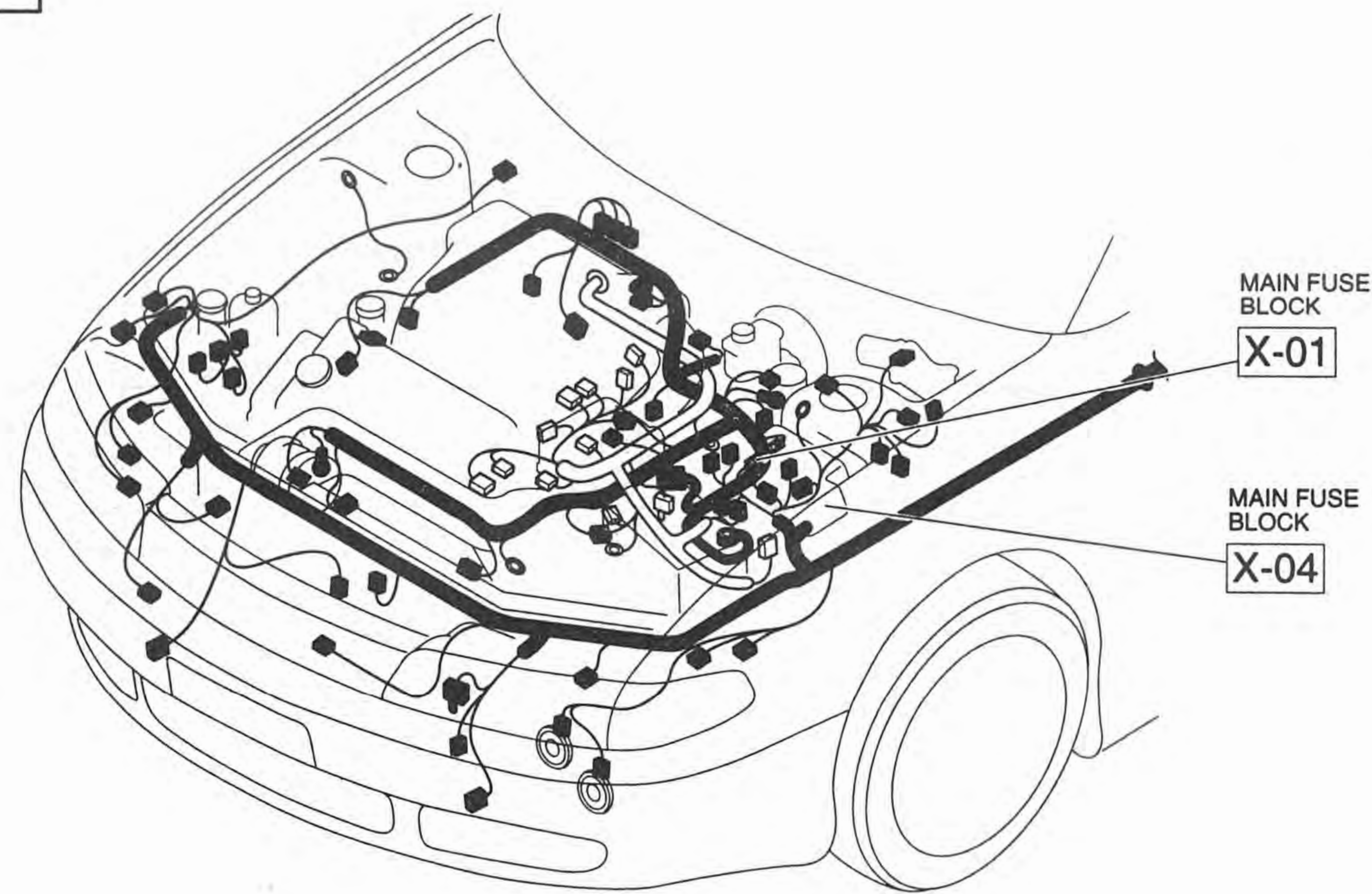

JOINT BOX

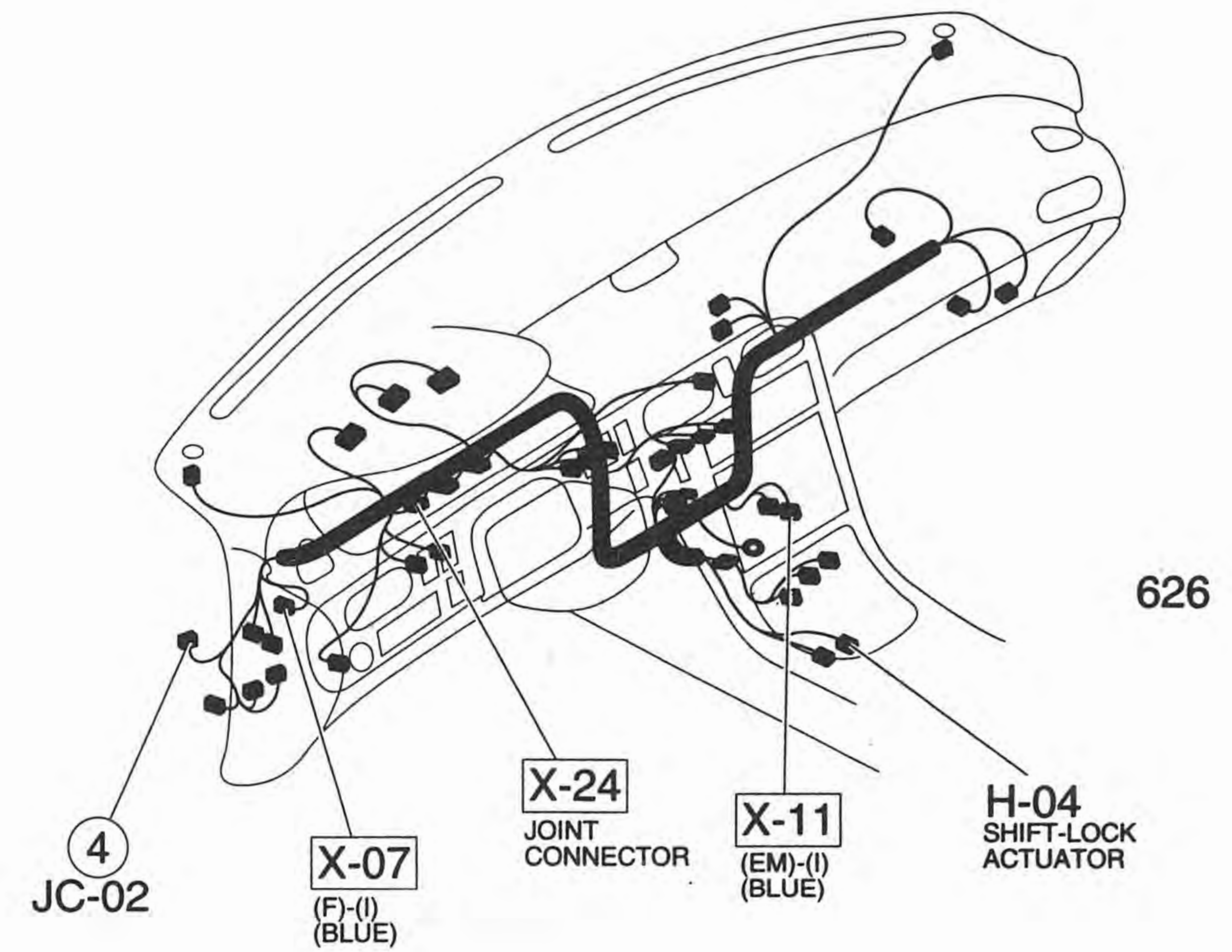
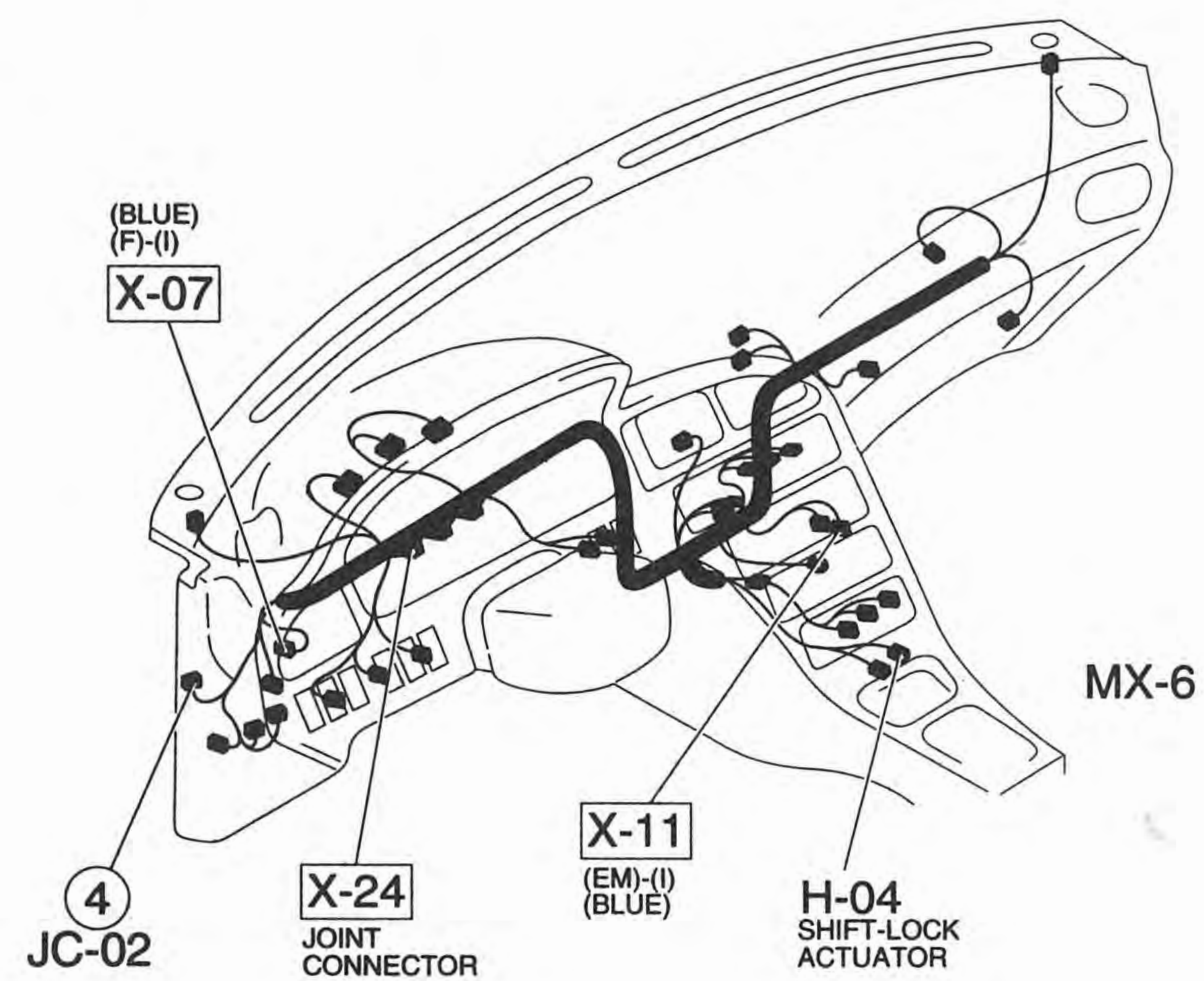
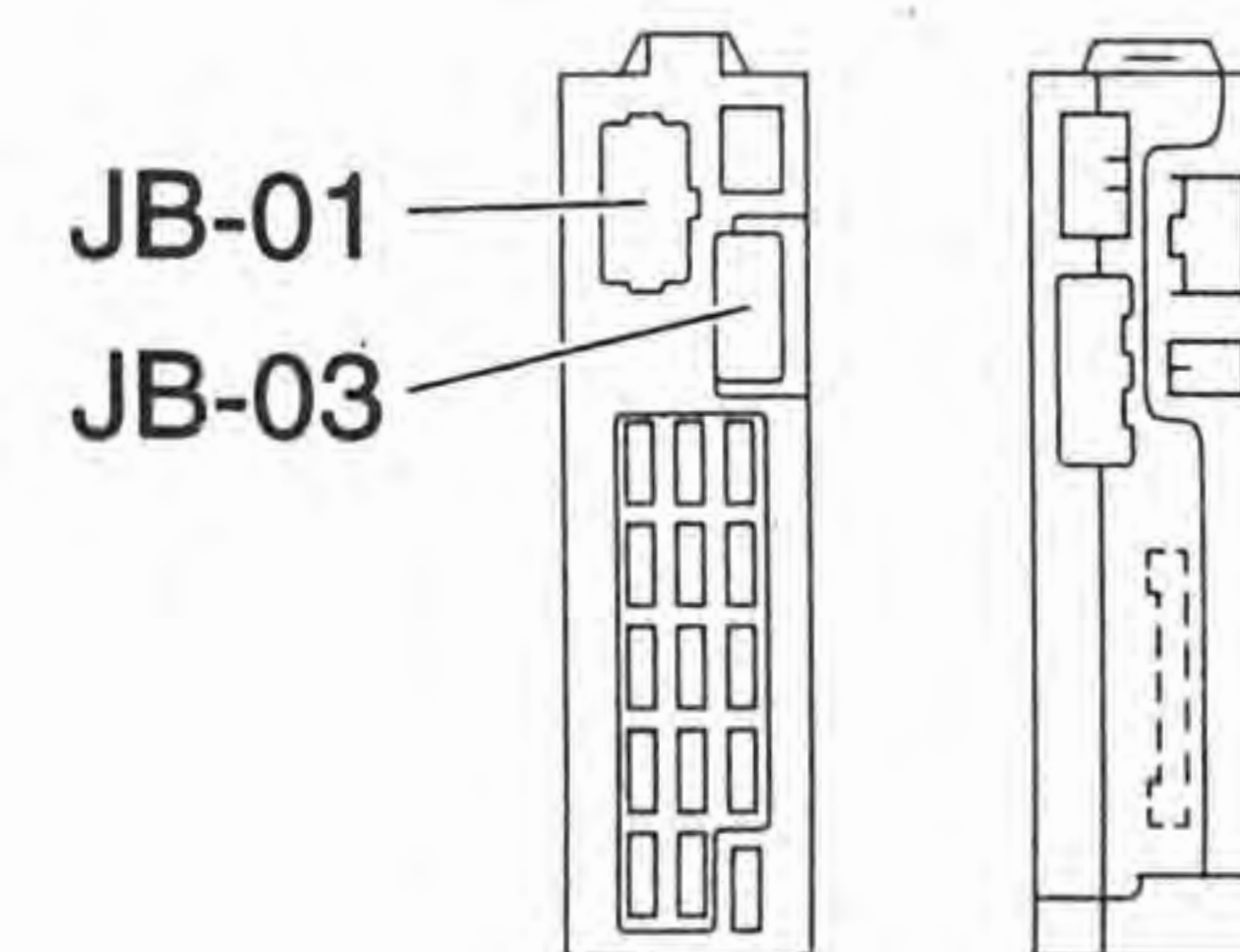

Z WIRING DIAGRAM

I-1a ■ GLOVE COMPARTMENT LIGHT ■ ILLUMINATION LIGHTS (1/2)



<p>I-01 GLOVE COMPARTMENT LIGHT (I)</p>	<p>I-02 GLOVE COMPARTMENT LIGHT SWITCH (I)</p>	<p>I-03 PANEL LIGHT CONTROL SWITCH (I)</p>	<p>I-04 SELECTOR ILLUMINATION (I)</p>	<p>I-05 ASHTRAY ILLUMINATION (IL)</p>	<p>I-06 CIGARETTE LIGHTER ILLUMINATION (IL)</p>	
<p>J-01 AUDIO ILLUMINATION (I)</p>						

I-1a

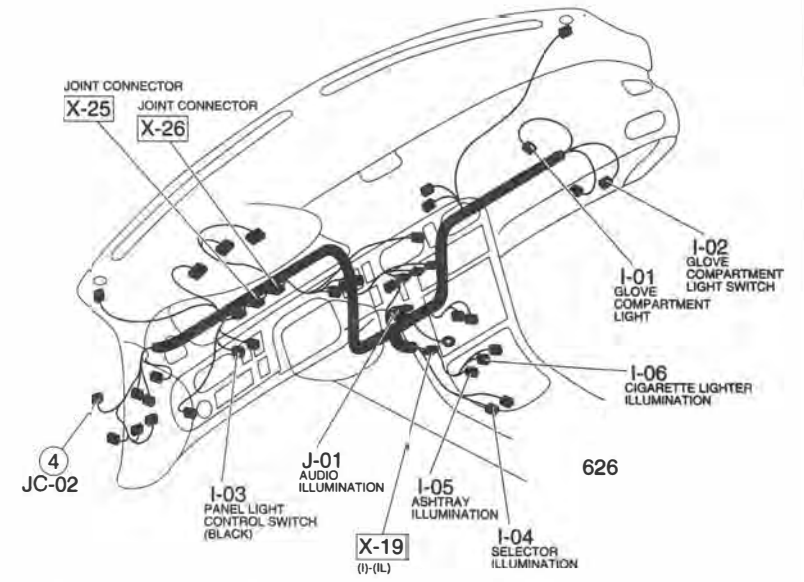
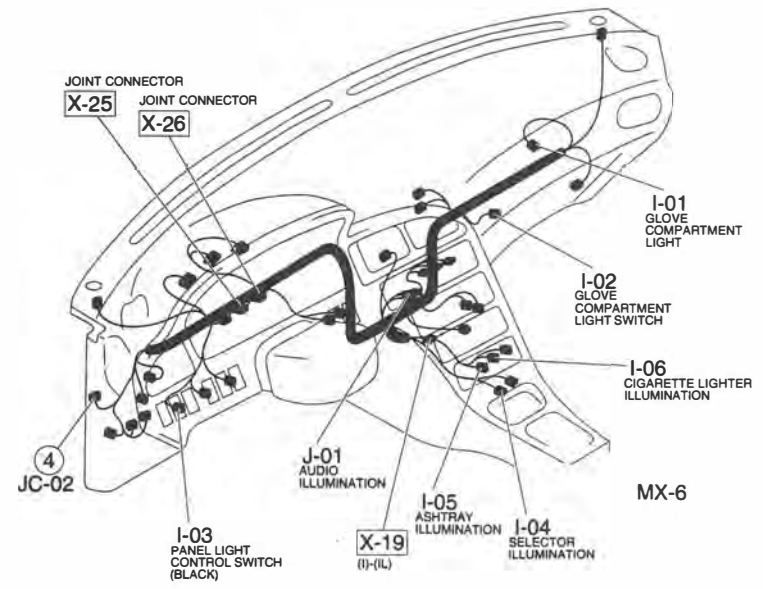
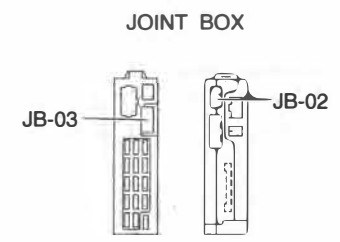
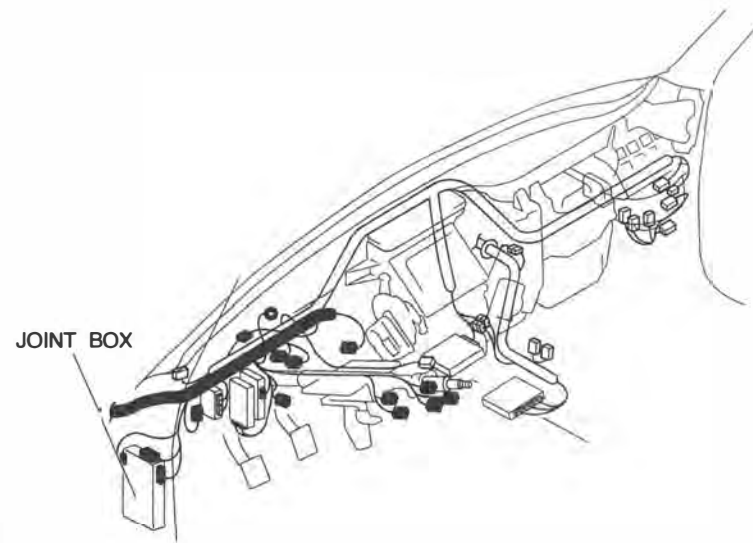

Z WIRING DIAGRAM

I-1b ■ ILLUMINATION LIGHTS (2/2)

•...MX-6

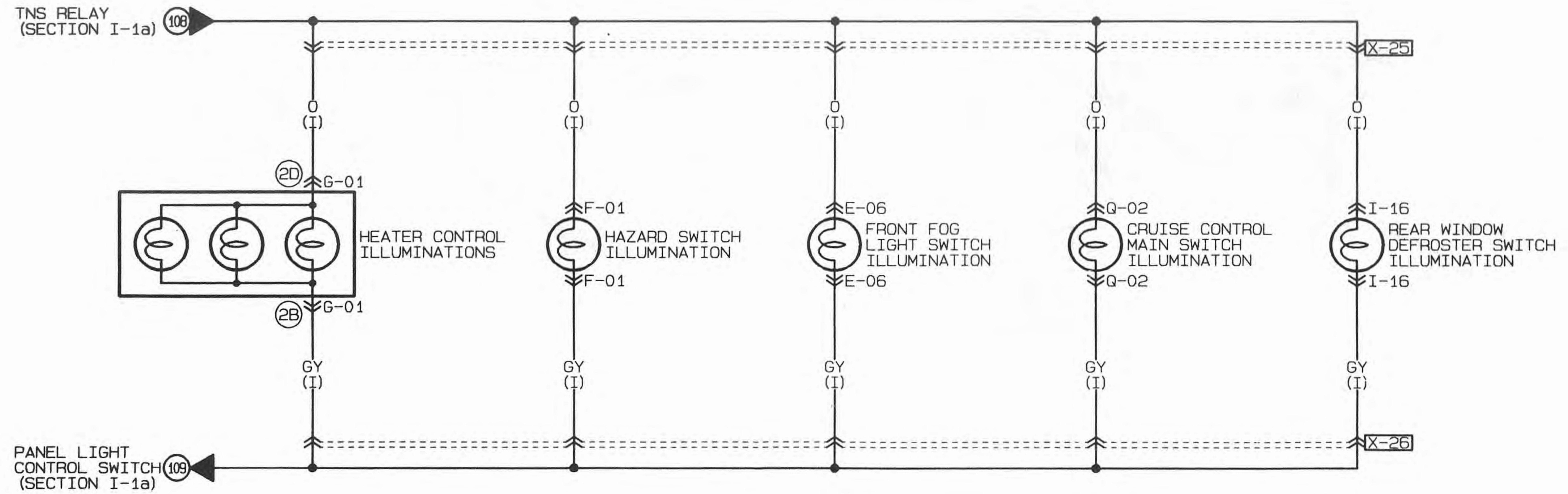

<p>E-06 FRONT FOG LIGHT SWITCH ILLUMINATION (I)</p> <table border="1" style="margin-left: auto; margin-right: auto;"> <tr><td>GY</td><td>O</td></tr> <tr><td>P</td><td>G/B</td></tr> </table>	GY	O	P	G/B	<p>F-01 HAZARD SWITCH ILLUMINATION (I)</p> <table border="1" style="margin-left: auto; margin-right: auto;"> <tr><td>B</td><td>W/L</td><td>B/Y</td><td>GY</td><td>O</td></tr> </table>	B	W/L	B/Y	GY	O	<p>G-01 HEATER CONTROL ILLUMINATIONS (I)</p> <table border="1" style="margin-left: auto; margin-right: auto;"> <tr> <td>20</td><td>2M</td><td>2K</td><td style="text-align: center;"></td><td>2E</td><td>2C</td><td>2A</td> </tr> <tr> <td>W/G</td><td>W/L</td><td>Y/W</td><td></td><td>R</td><td>W/B</td><td>W</td> </tr> <tr> <td>B/R</td><td>W/Y</td><td>Y</td><td>L</td><td>G/L</td><td>L/W</td><td>O</td><td>GY</td> </tr> <tr> <td>2P</td><td>2N</td><td>2L</td><td>2J</td><td>2H</td><td>2F</td><td>2D</td><td>2B</td> </tr> </table>	20	2M	2K		2E	2C	2A	W/G	W/L	Y/W		R	W/B	W	B/R	W/Y	Y	L	G/L	L/W	O	GY	2P	2N	2L	2J	2H	2F	2D	2B	<p>I-16 REAR WINDOW DEFROSTER SWITCH ILLUMINATION (I)</p> <table border="1" style="margin-left: auto; margin-right: auto;"> <tr><td>O</td><td>GY</td><td>*</td><td>B</td><td>G</td><td>*</td></tr> </table>	O	GY	*	B	G	*
GY	O																																															
P	G/B																																															
B	W/L	B/Y	GY	O																																												
20	2M	2K		2E	2C	2A																																										
W/G	W/L	Y/W		R	W/B	W																																										
B/R	W/Y	Y	L	G/L	L/W	O	GY																																									
2P	2N	2L	2J	2H	2F	2D	2B																																									
O	GY	*	B	G	*																																											
<p>Q-02 CRUISE CONTROL MAIN SWITCH ILLUMINATION (I)</p> <table border="1" style="margin-left: auto; margin-right: auto;"> <tr><td>B</td><td>W/L</td><td>B/Y</td><td>GY</td><td>O</td></tr> </table>	B	W/L	B/Y	GY	O																																											
B	W/L	B/Y	GY	O																																												

I-1b

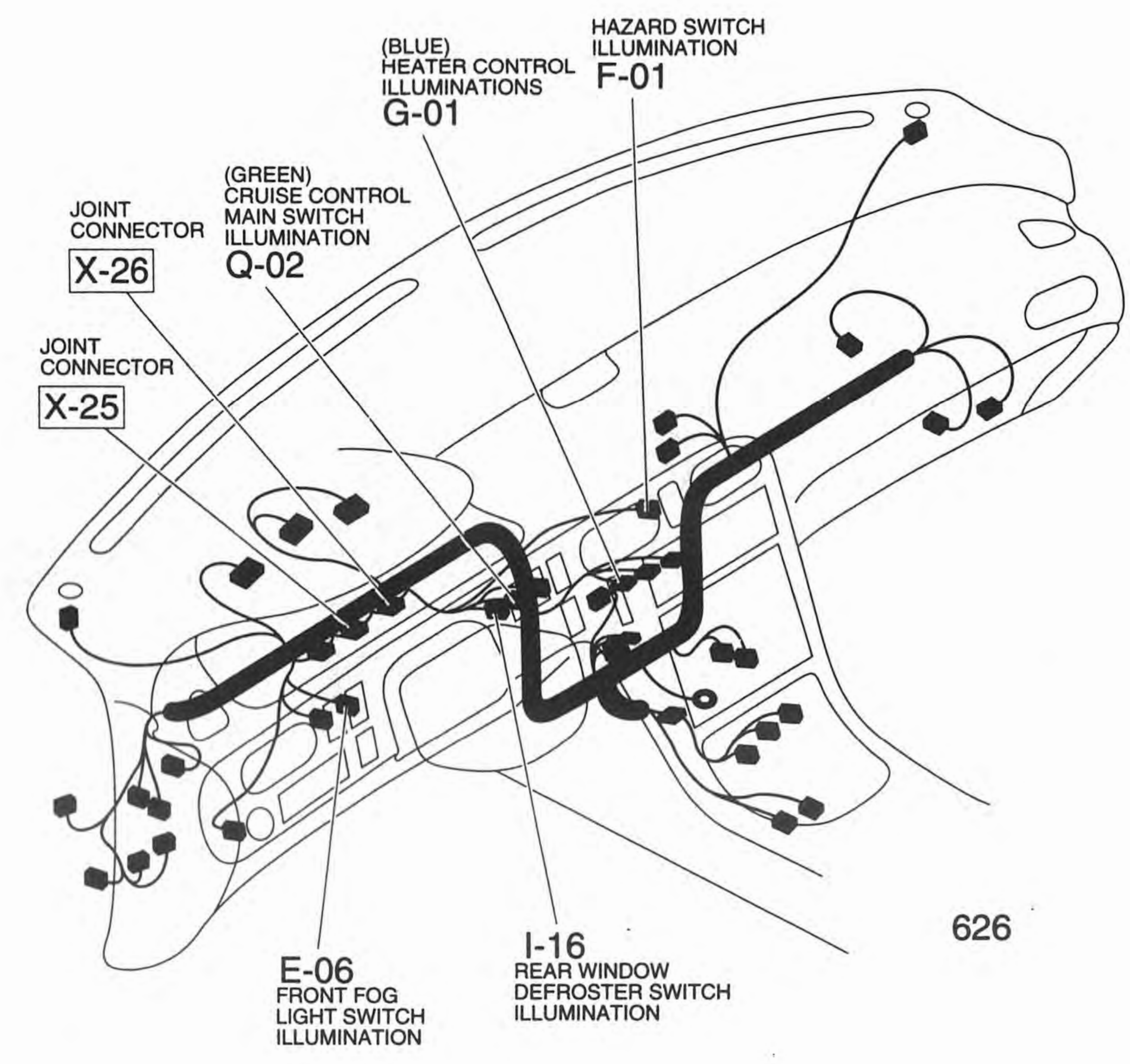
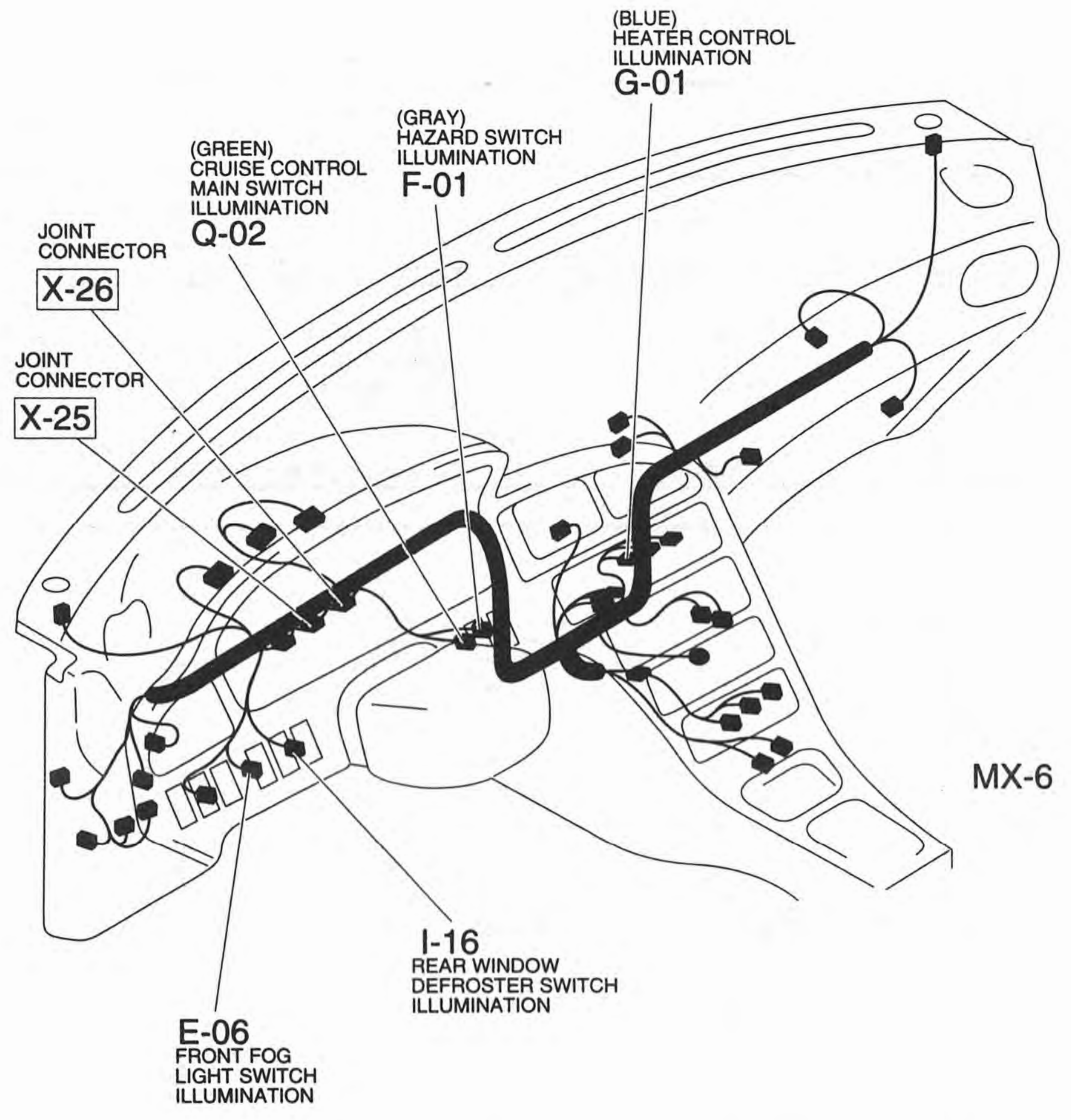

Z WIRING DIAGRAM

I-2

626

- COURTESY LIGHTS
- INTERIOR LIGHT
- IGNITION KEY ILLUMINATION
- VANITY MIRROR LIGHTS
- SPOT LIGHTS

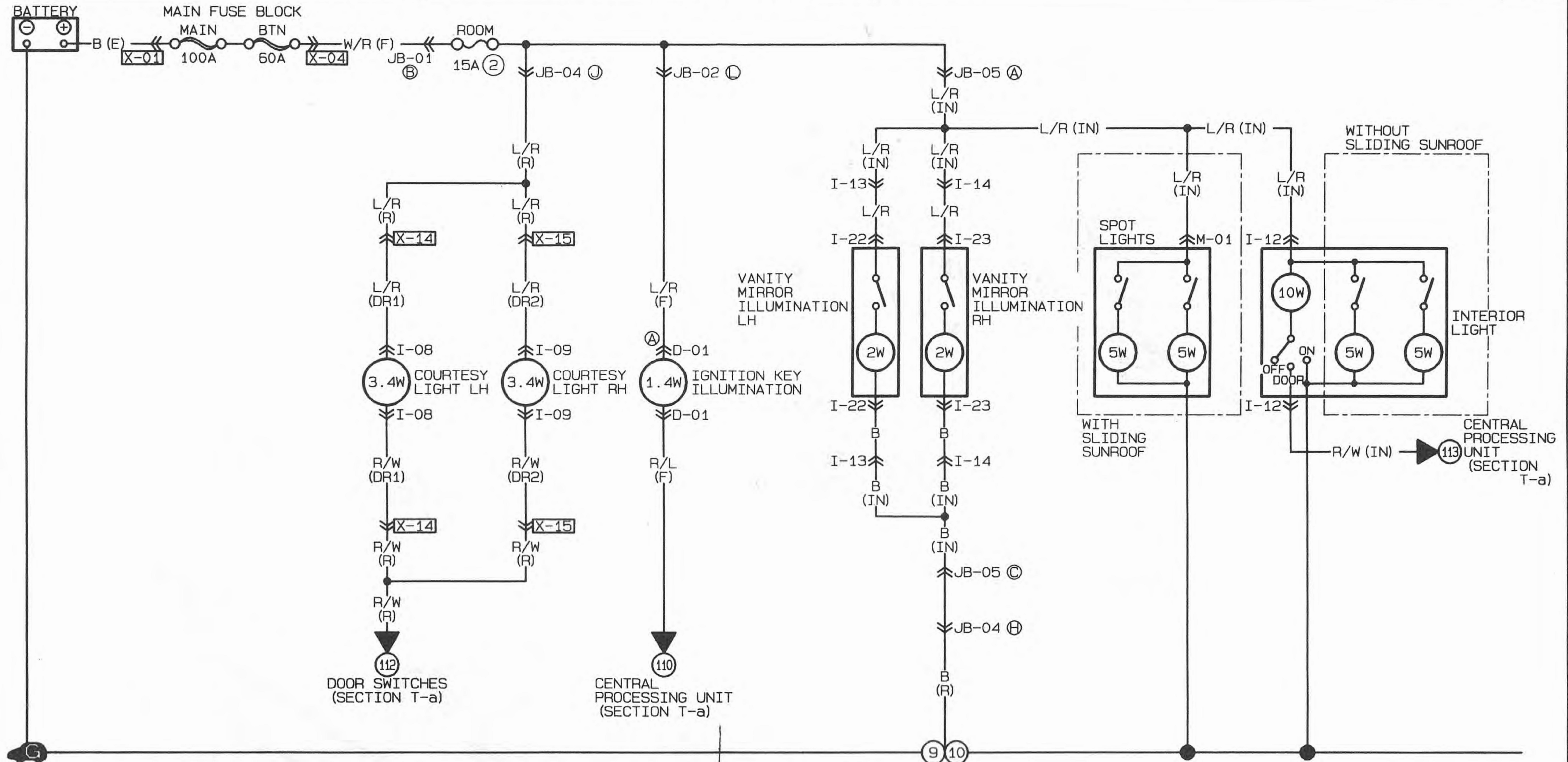

I-08 COURTESY LIGHT LH (DR1) 	I-09 COURTESY LIGHT RH (DR2) 	I-12 INTERIOR LIGHT (IN) 	I-13 INTERIOR LIGHT (IN) - VANITY MIRROR ILLUMINATION LH 	I-14 INTERIOR LIGHT (IN) - VANITY MIRROR ILLUMINATION RH 	I-22 VANITY MIRROR ILLUMINATION LH 	I-23 VANITY MIRROR ILLUMINATION RH 	D-01 IGNITION KEY ILLUMINATION (F) <table border="1" style="width: 100%; border-collapse: collapse; text-align: center;"> <tr> <td style="width: 10%;"></td> <td style="width: 10%;">L/O</td> <td style="width: 10%;">L/B</td> <td style="width: 10%;"></td> <td style="width: 10%;">B</td> <td style="width: 10%;">LG</td> <td style="width: 10%;">L/R</td> </tr> <tr> <td>*</td> <td>L/W</td> <td>L/R</td> <td>L</td> <td>B</td> <td>B/G</td> <td>W/R R/L</td> </tr> </table>		L/O	L/B		B	LG	L/R	*	L/W	L/R	L	B	B/G	W/R R/L	M-01 SPOT LIGHTS (IN) 		
	L/O	L/B		B	LG	L/R																		
*	L/W	L/R	L	B	B/G	W/R R/L																		

I-2

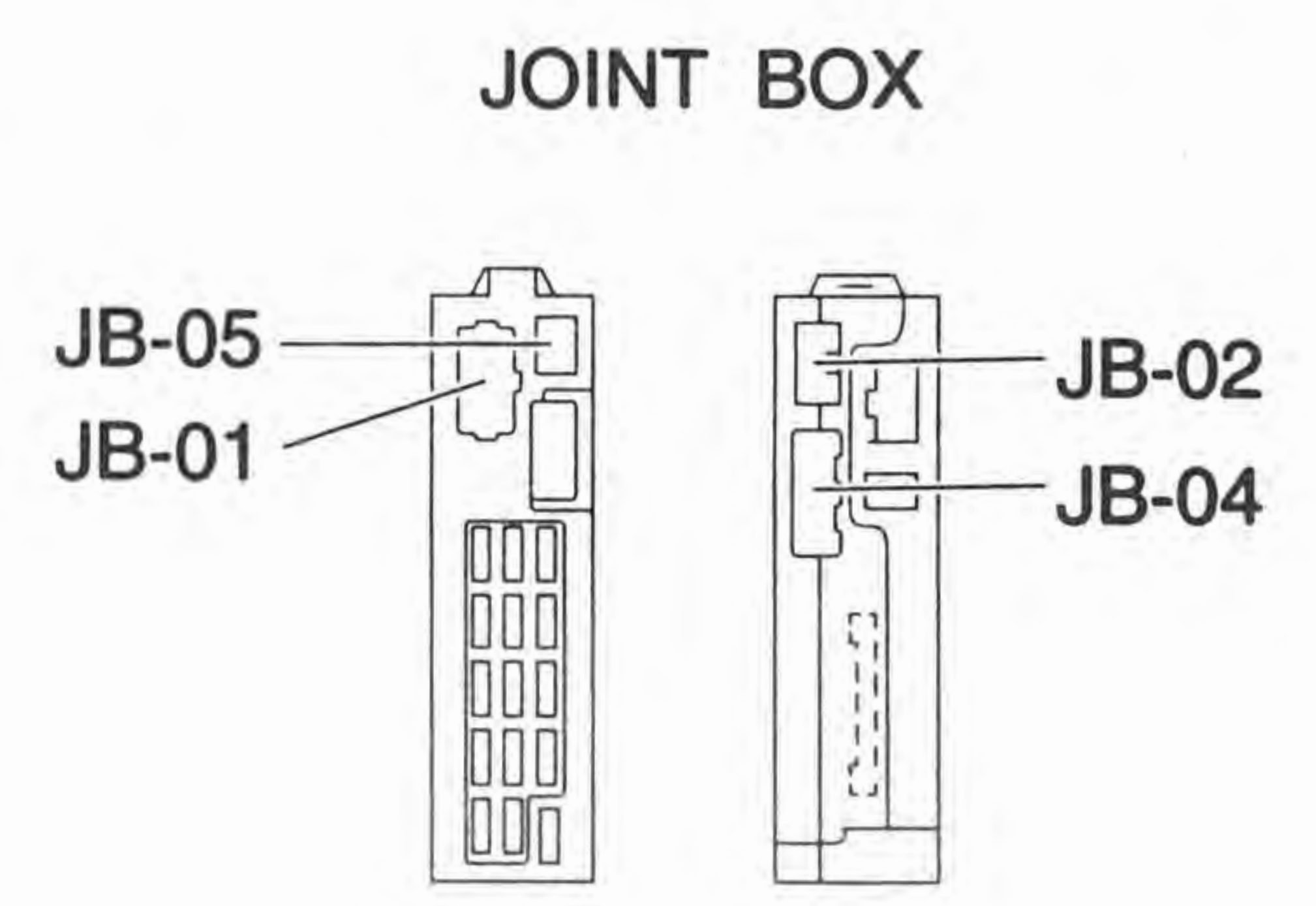
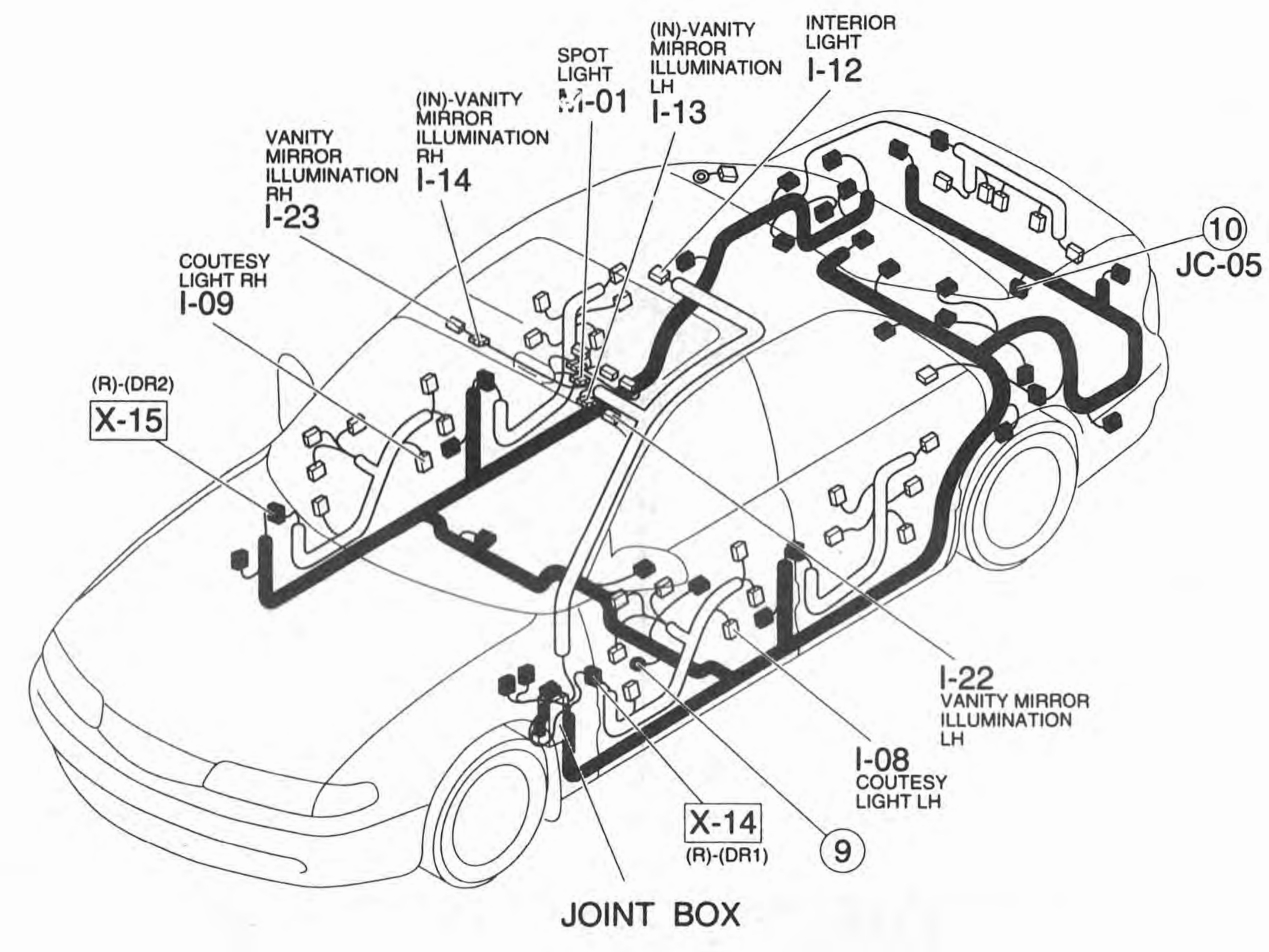
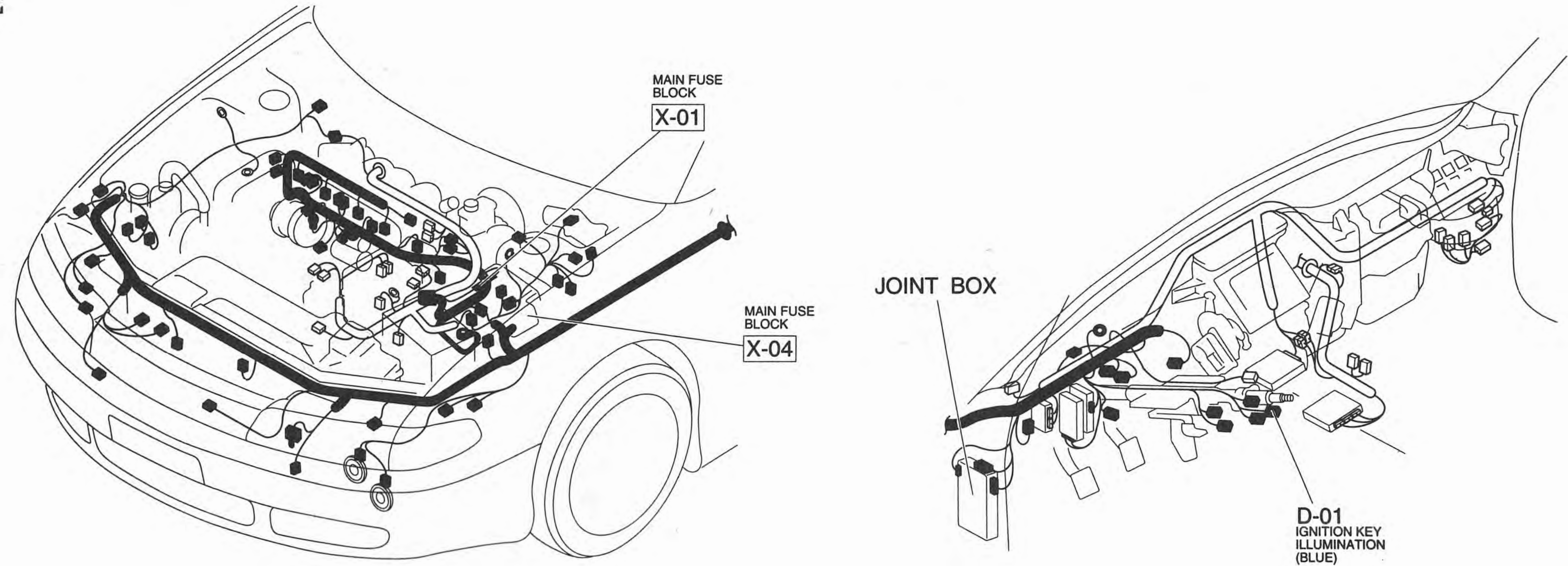

Z WIRING DIAGRAM

I-3 MX-6 ■ COURTESY LIGHTS ■ IGNITION KEY ILLUMINATION
 ■ INTERIOR LIGHT ■ SPOT LIGHTS

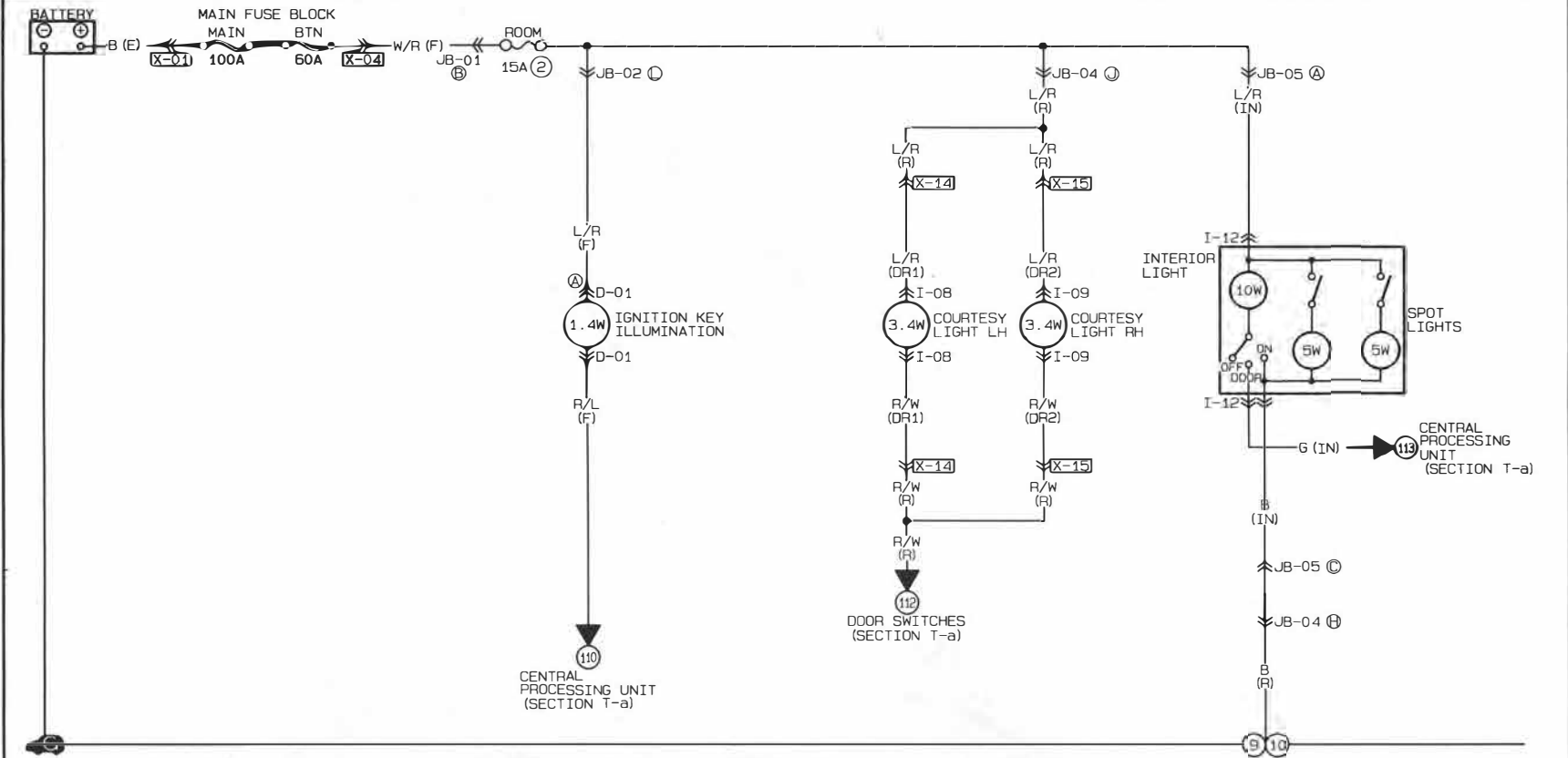

<p>I-08 COURTESY LIGHT LH (DR1)</p>	<p>I-09 COURTESY LIGHT RH (DR2)</p>	<p>I-12 INTERIOR LIGHT AND SPOT LIGHTS (IN)</p>	<p>D-01 IGNITION KEY ILLUMINATION (F)</p>		

I-3

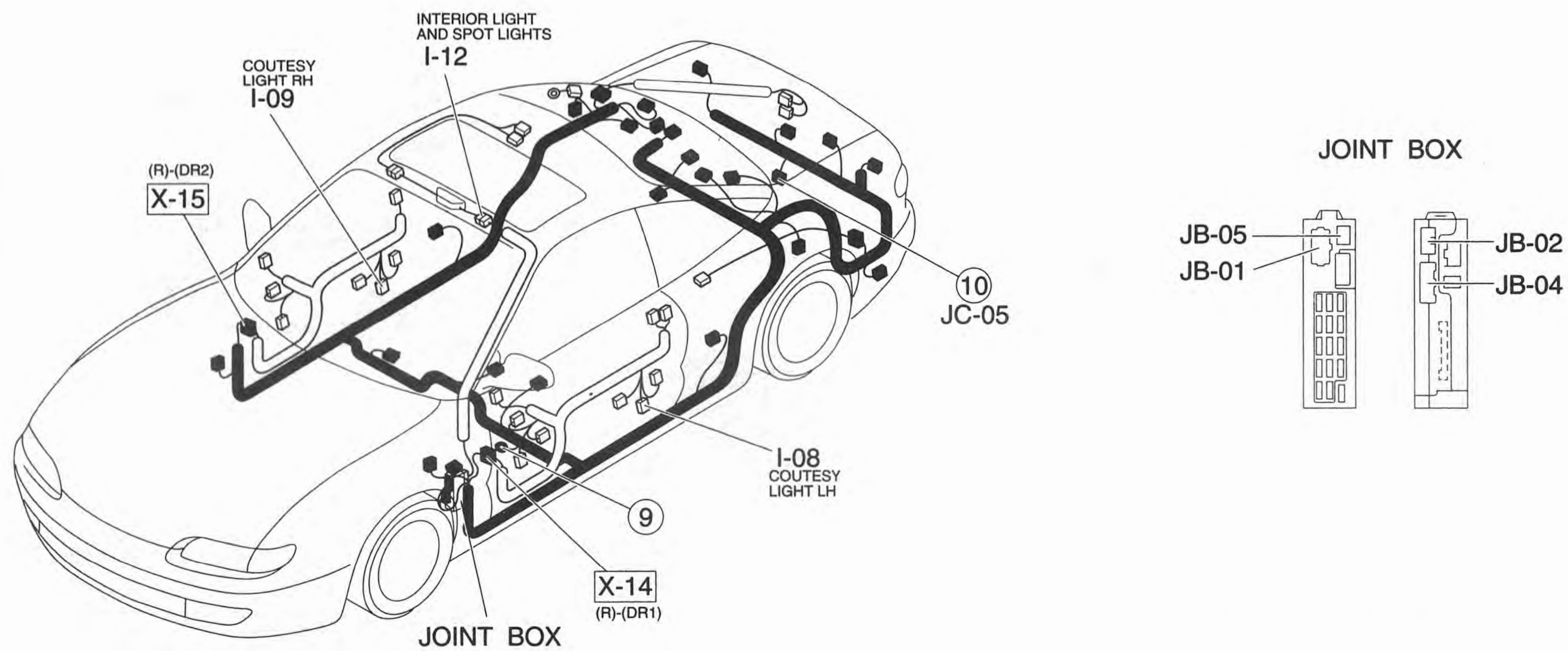
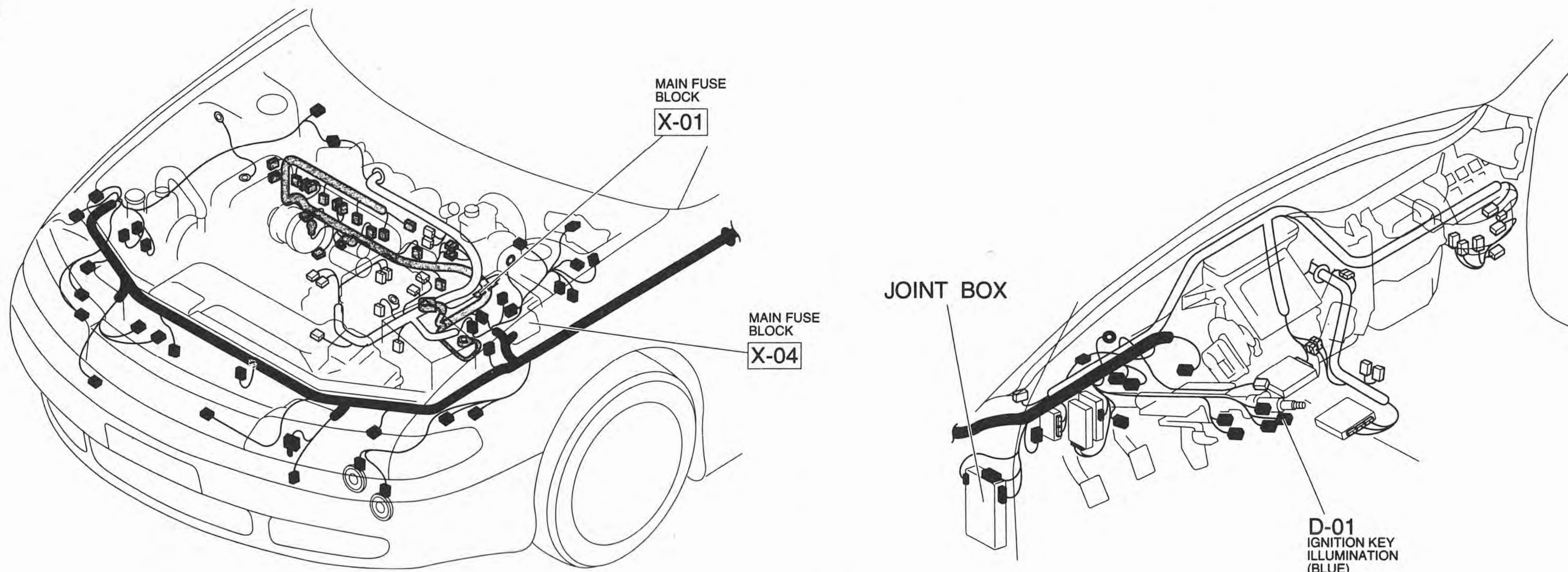

Z WIRING DIAGRAM

I-4

626

■ REAR WINDOW DEFROSTER
■ TRUNK COMPARTMENT LIGHT

■ CIGARETTE LIGHTER

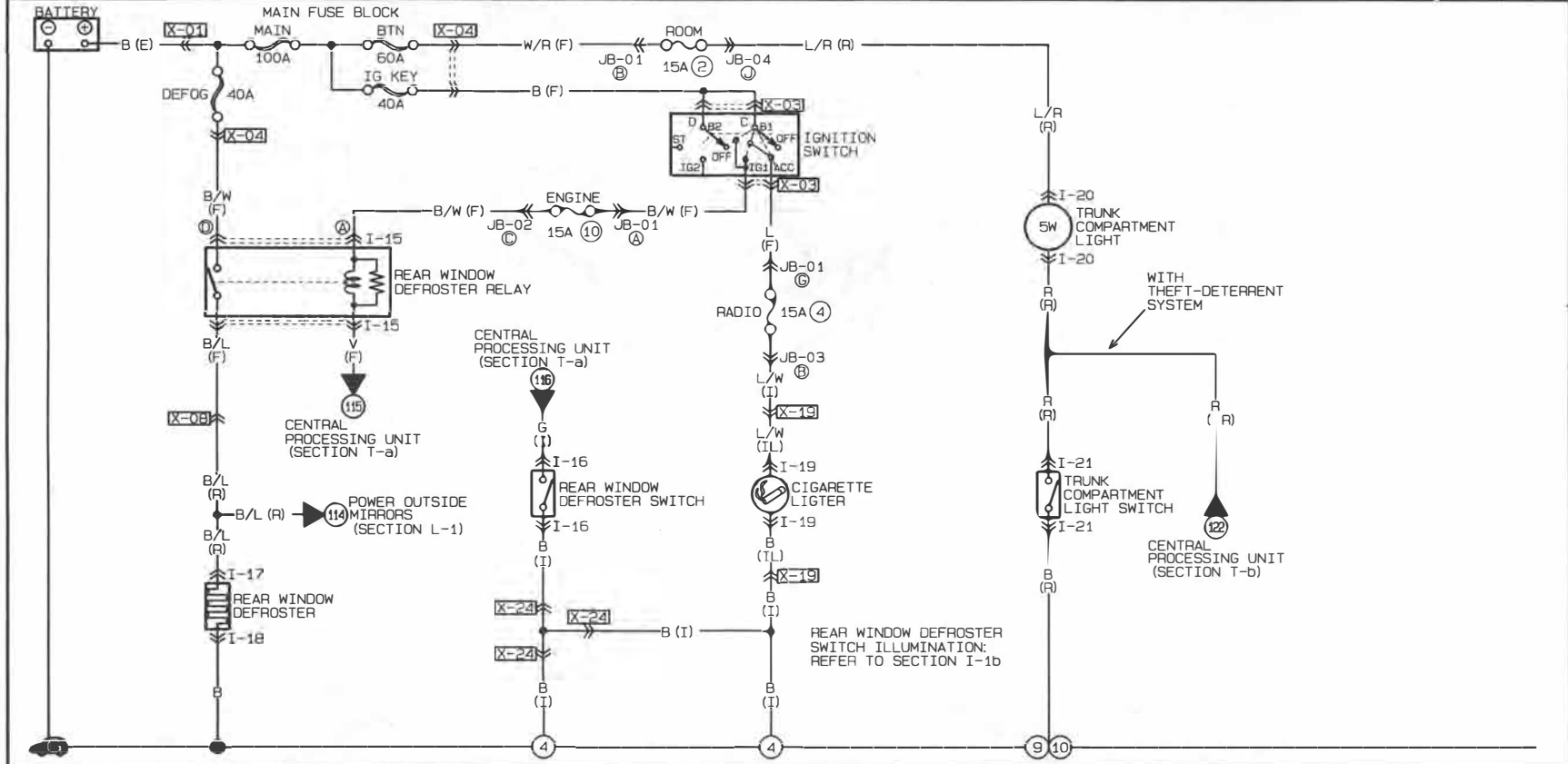

<p>I-15 REAR WINDOW DEFROSTER RELAY (F)</p>	<p>I-16 REAR WINDOW DEFROSTER SWITCH (I)</p>	<p>I-17 REAR WINDOW DEFROSTER (R)</p>	<p>I-18 REAR WINDOW DEFROSTER</p>	<p>I-19 CIGARETTE LIGHTER (IL)</p>	<p>I-20 TRUNK COMPARTMENT LIGHT (R)</p>
<p>I-21 TRUNK COMPARTMENT LIGHT SWITCH (R)</p>					

I-4

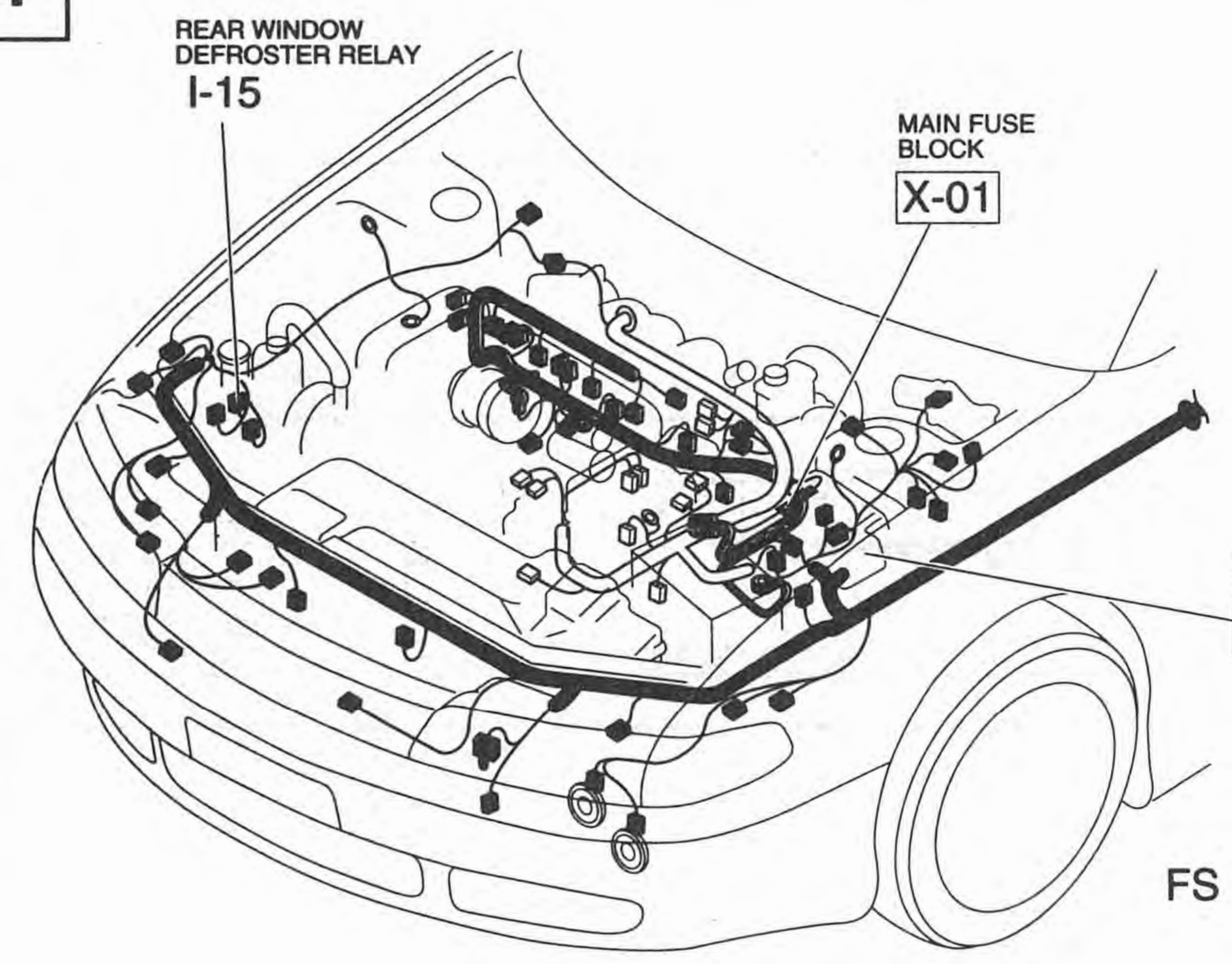

JOINT BOX

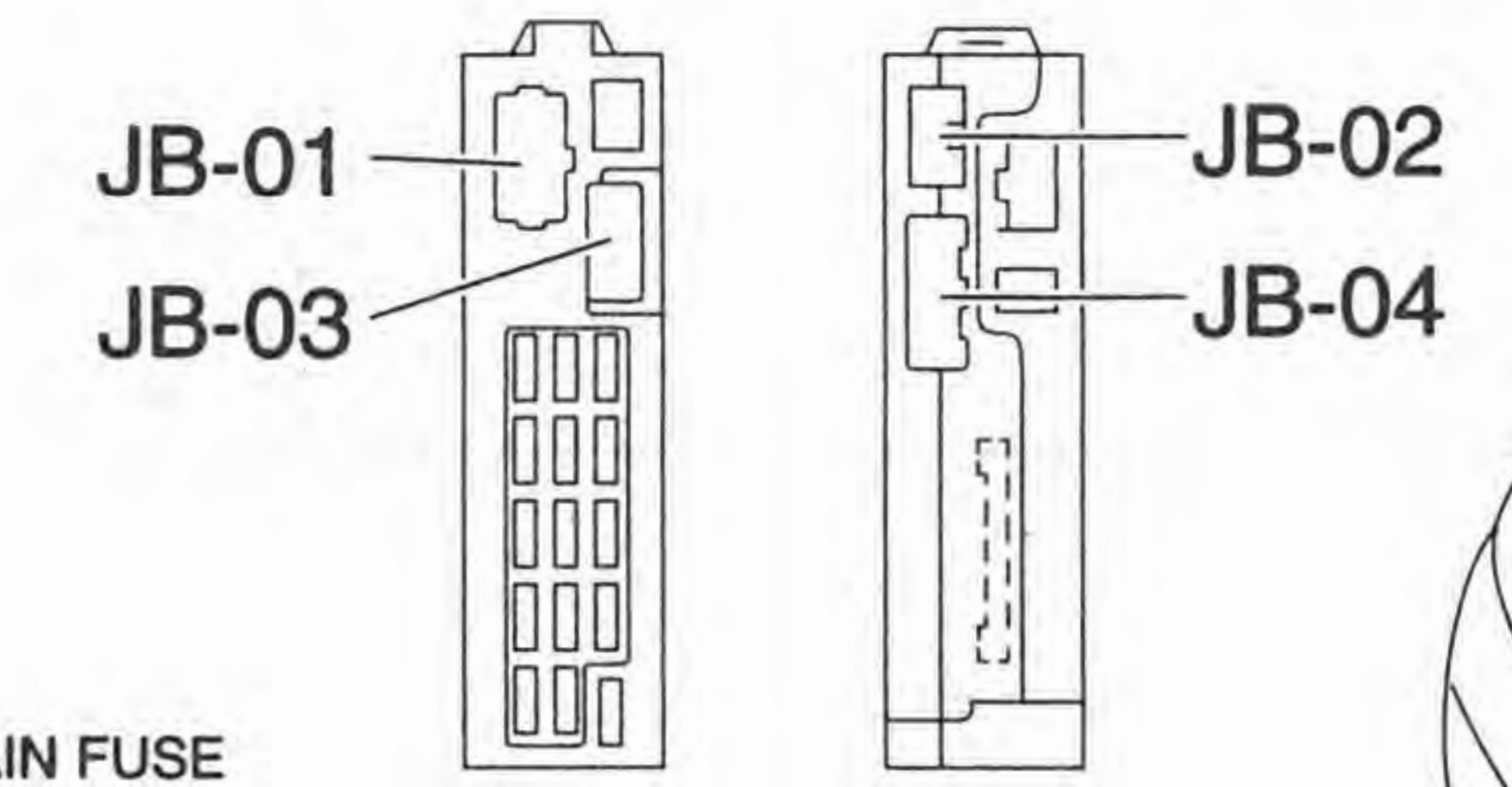

MAIN FUSE BLOCK X-04

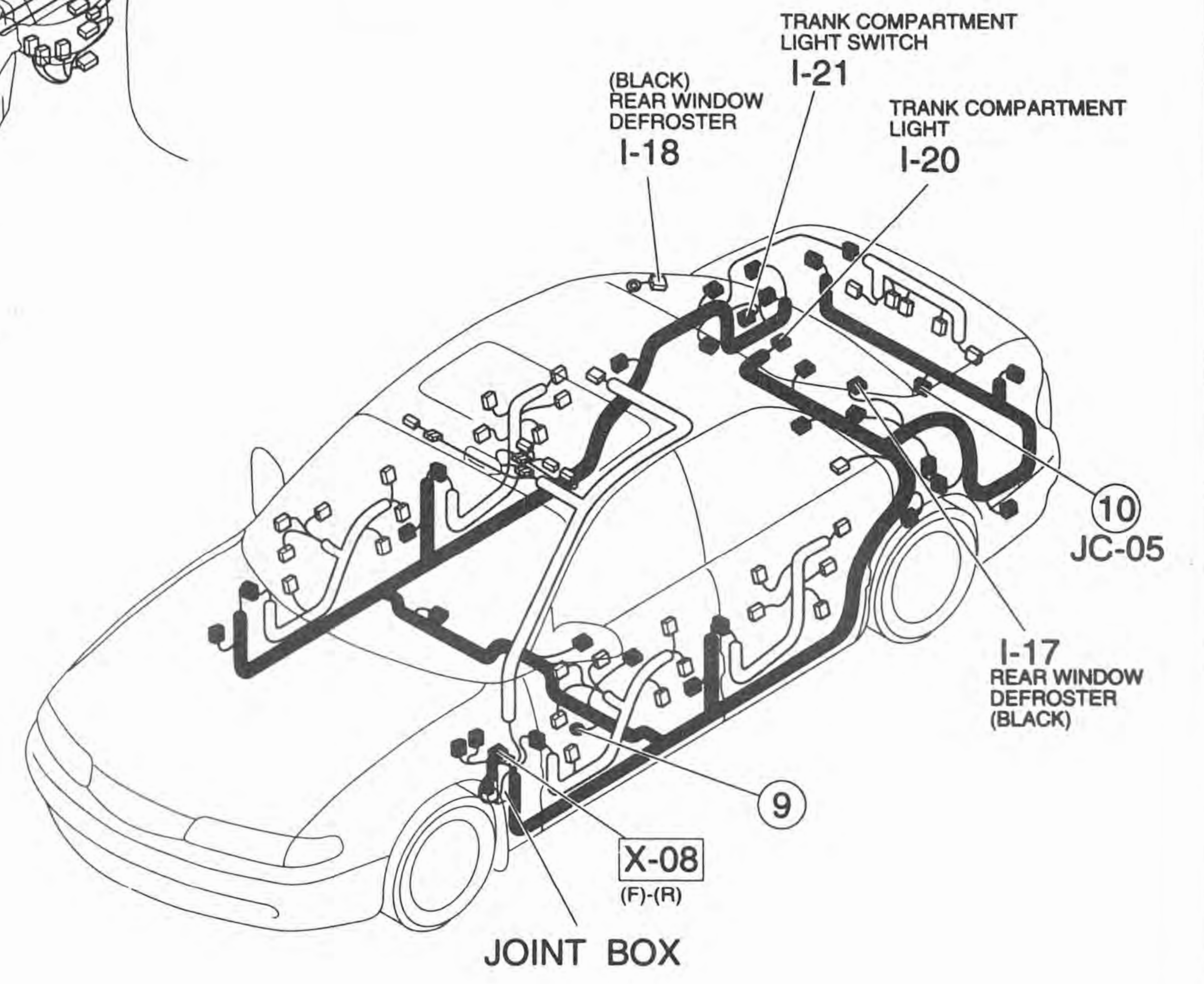
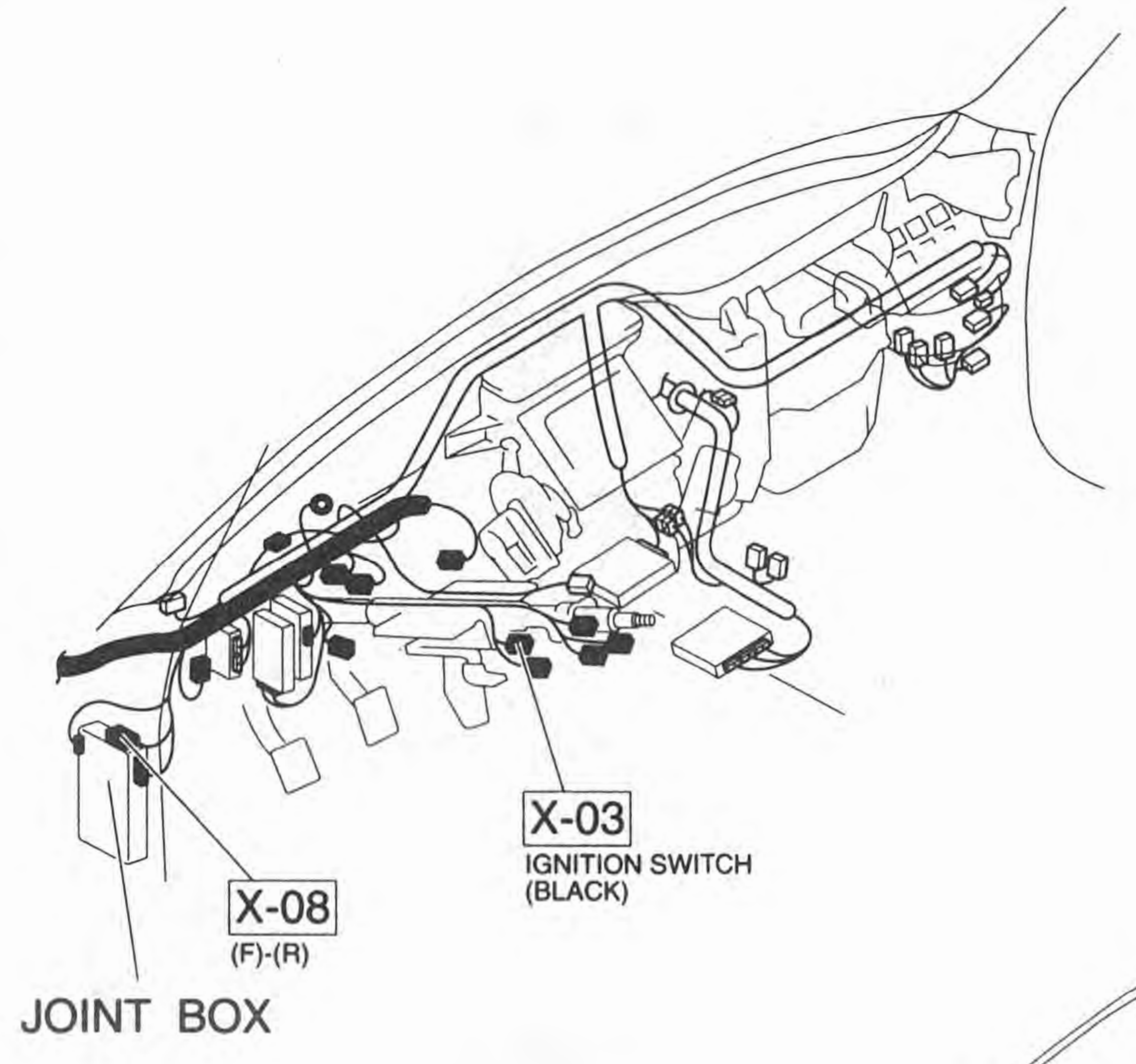
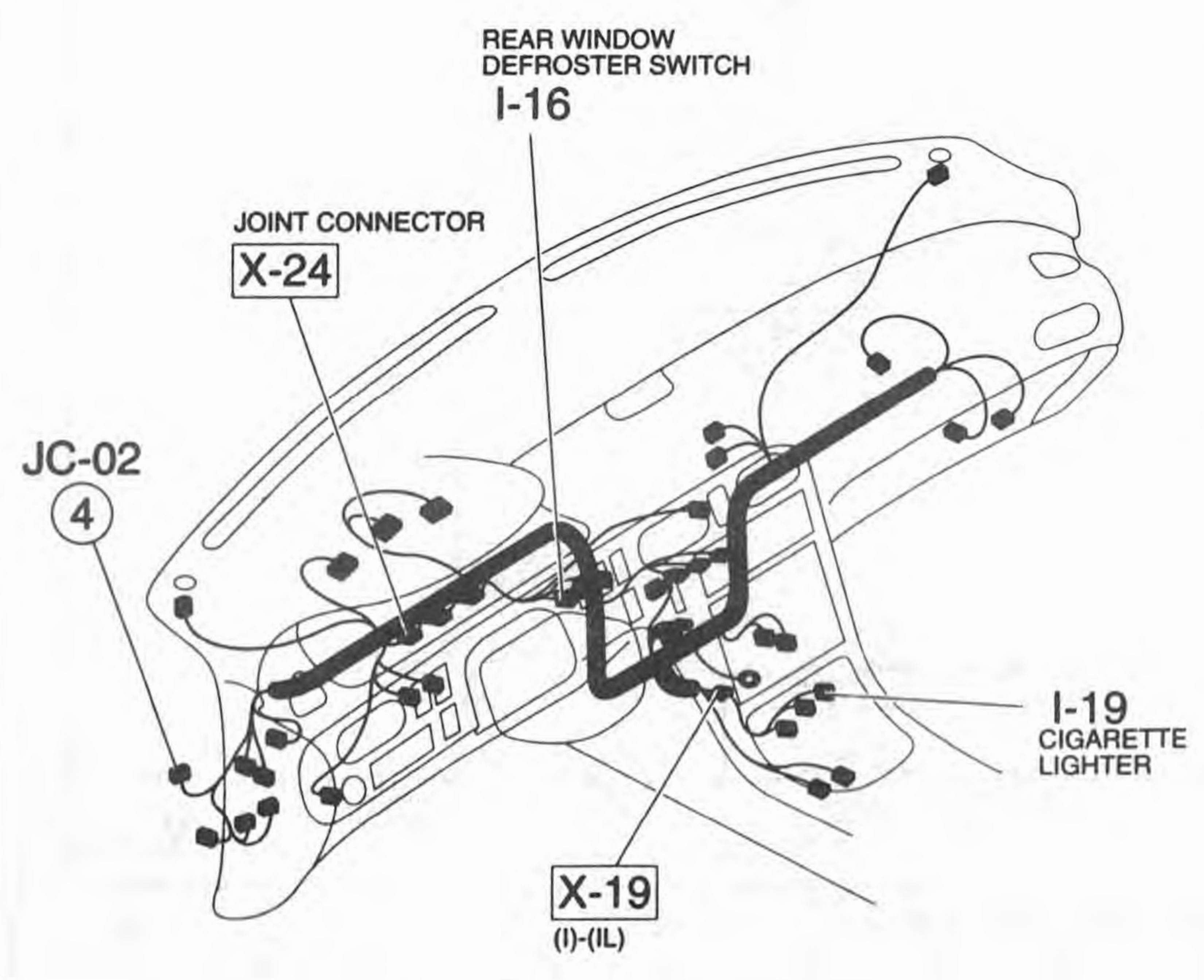
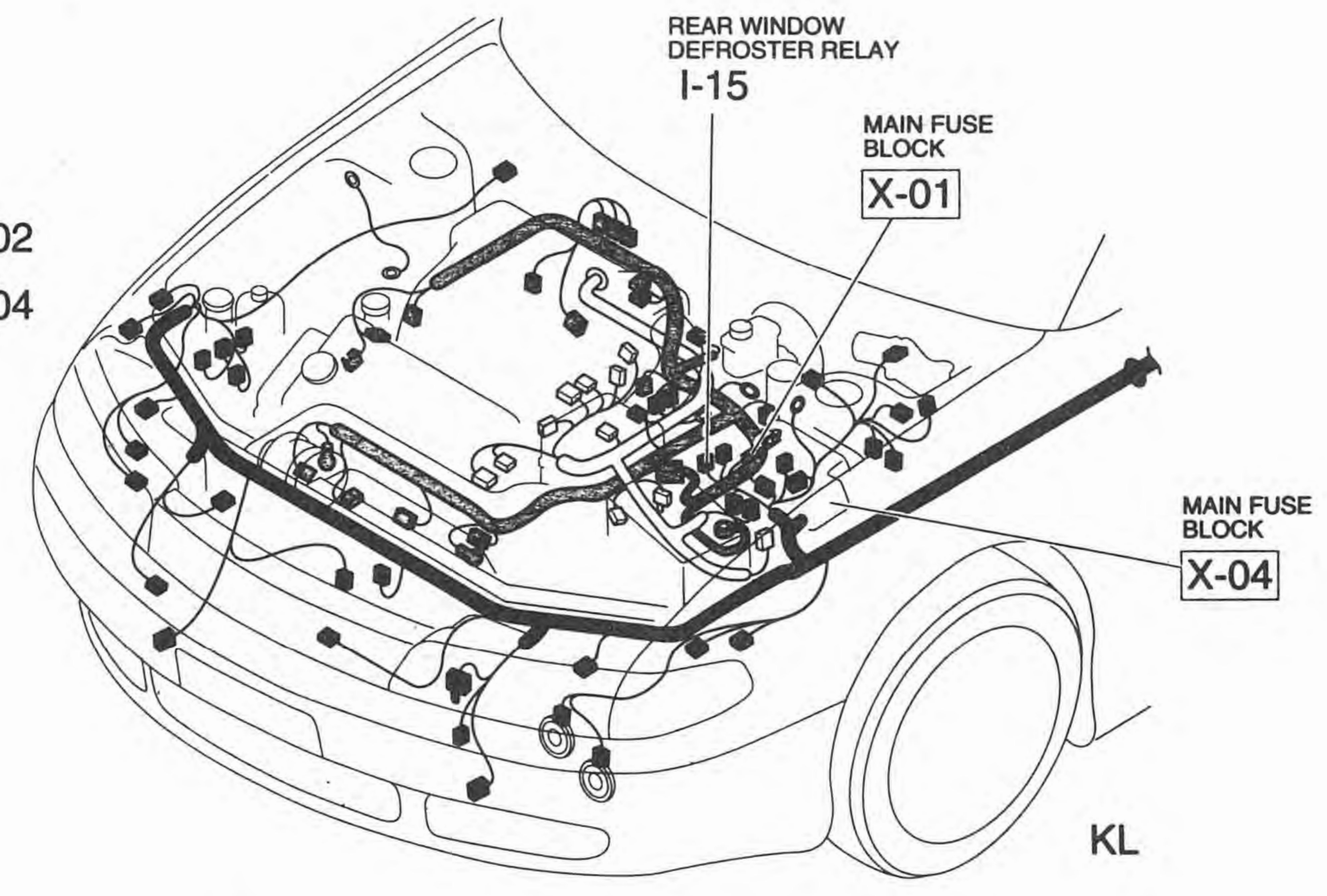

Z WIRING DIAGRAM

I-5 MX-6 ■ REAR WINDOW DEFROSTER ■ CIGARETTE LIGHTER
■ TRUNK COMPARTMENT LIGHT

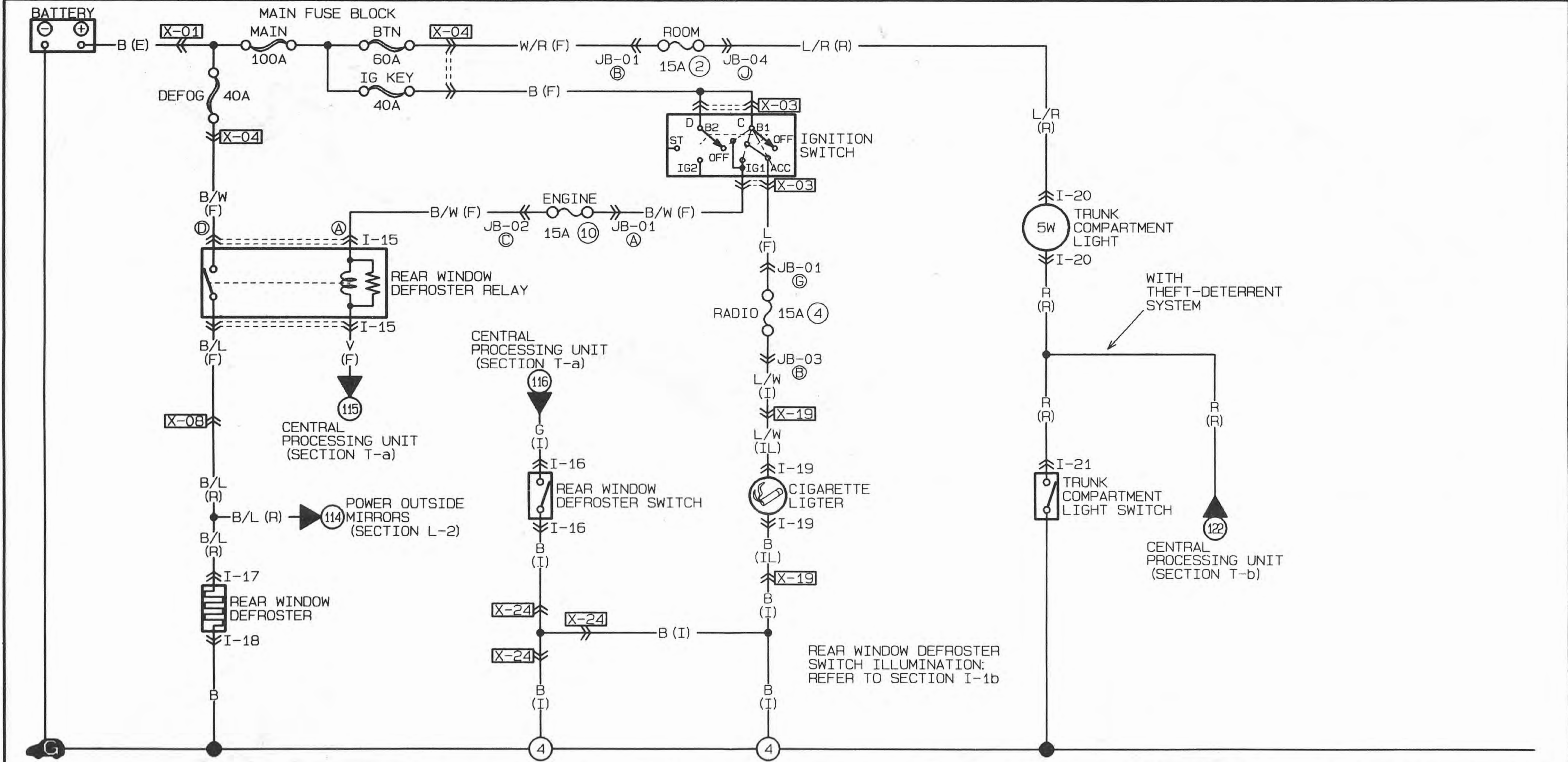

<p>I-15 REAR WINDOW DEFROSTER RELAY (F)</p>	<p>I-16 REAR WINDOW DEFROSTER SWITCH (I)</p>	<p>I-17 REAR WINDOW DEFROSTER (R)</p>	<p>I-18 REAR WINDOW DEFROSTER</p>	<p>I-19 CIGARETTE LIGHTER (IL)</p>	<p>I-20 TRUNK COMPARTMENT LIGHT (R)</p>
<p>I-21 TRUNK COMPARTMENT LIGHT SWITCH (R)</p>					

I-5

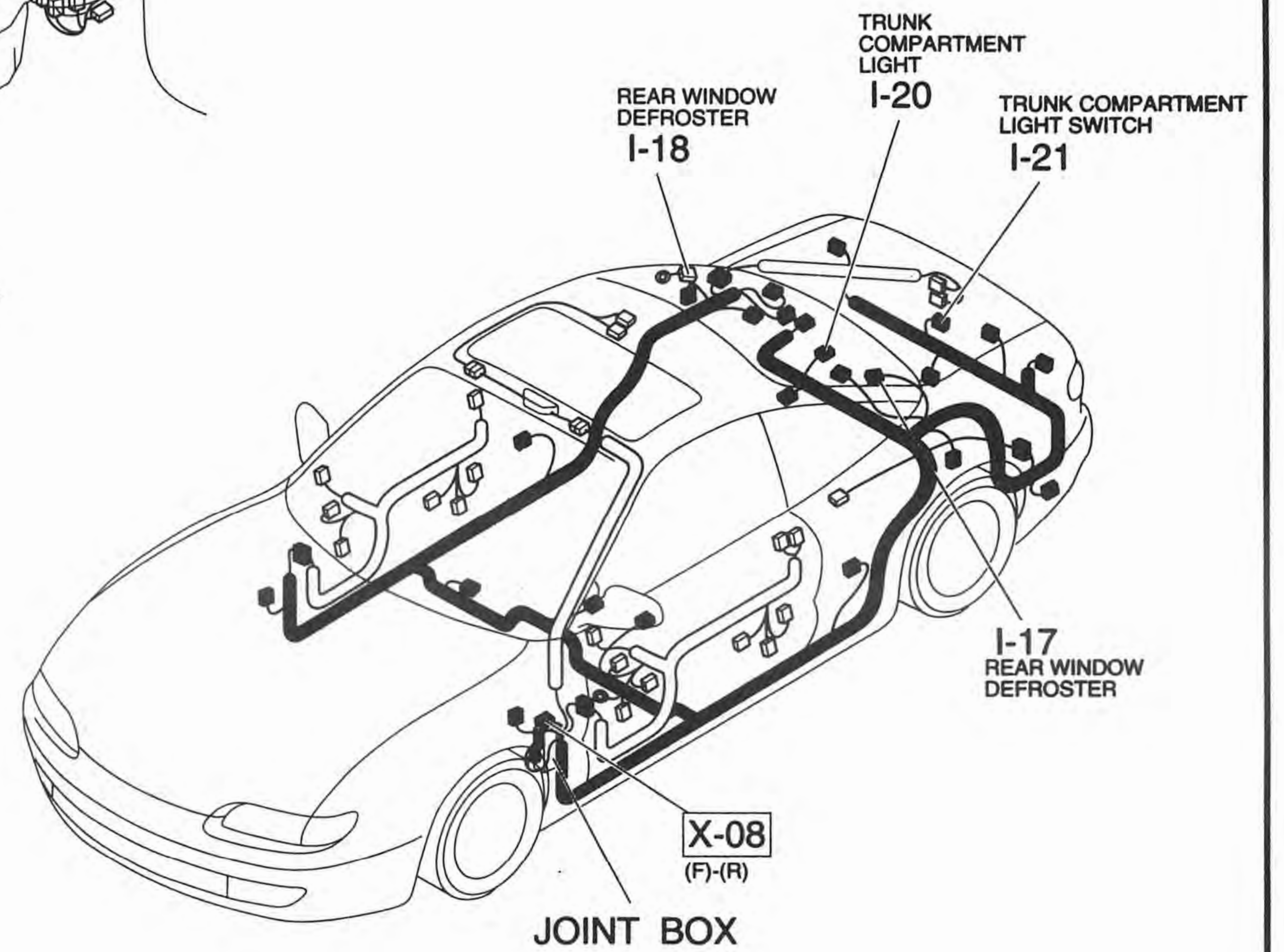
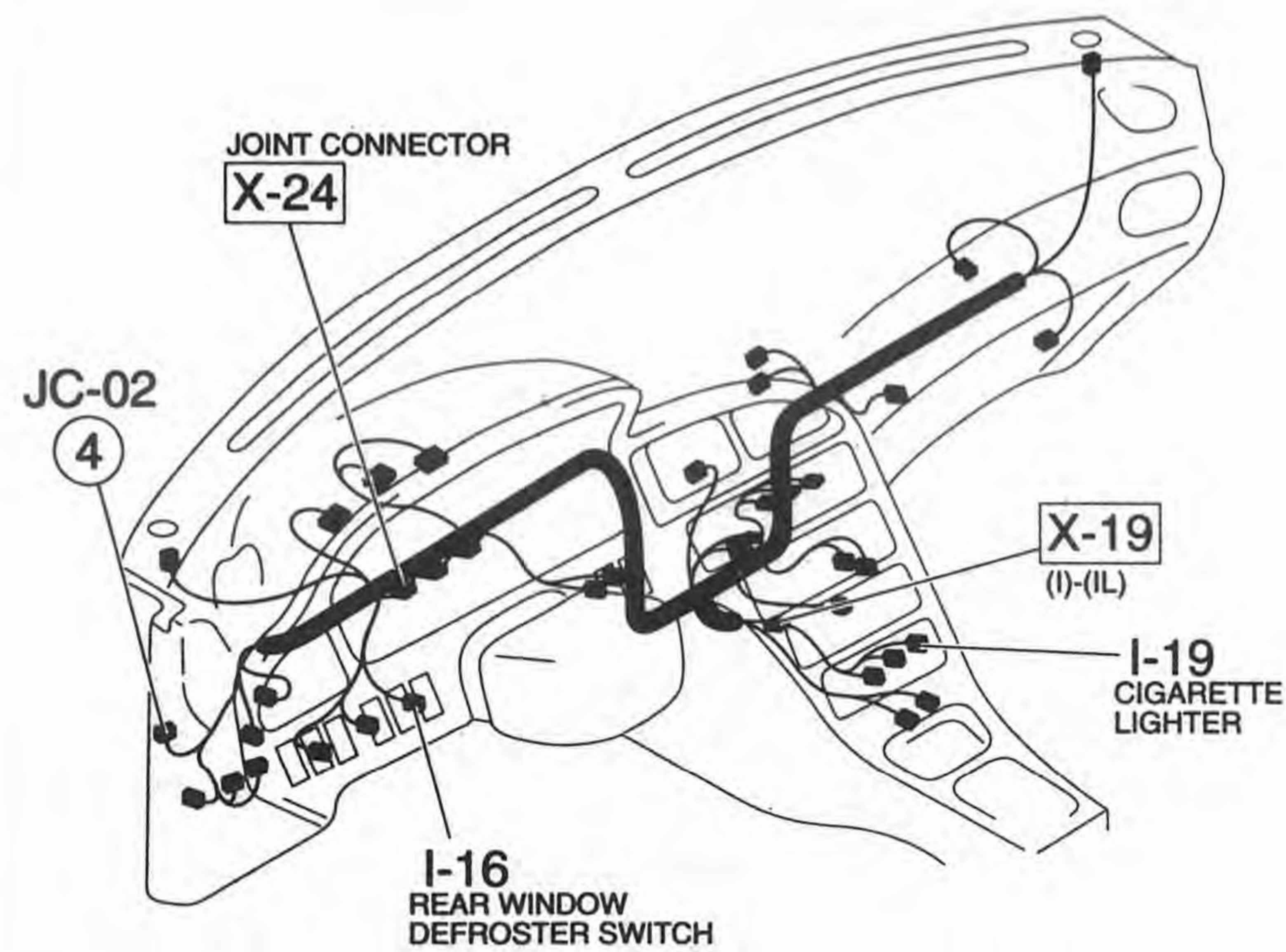
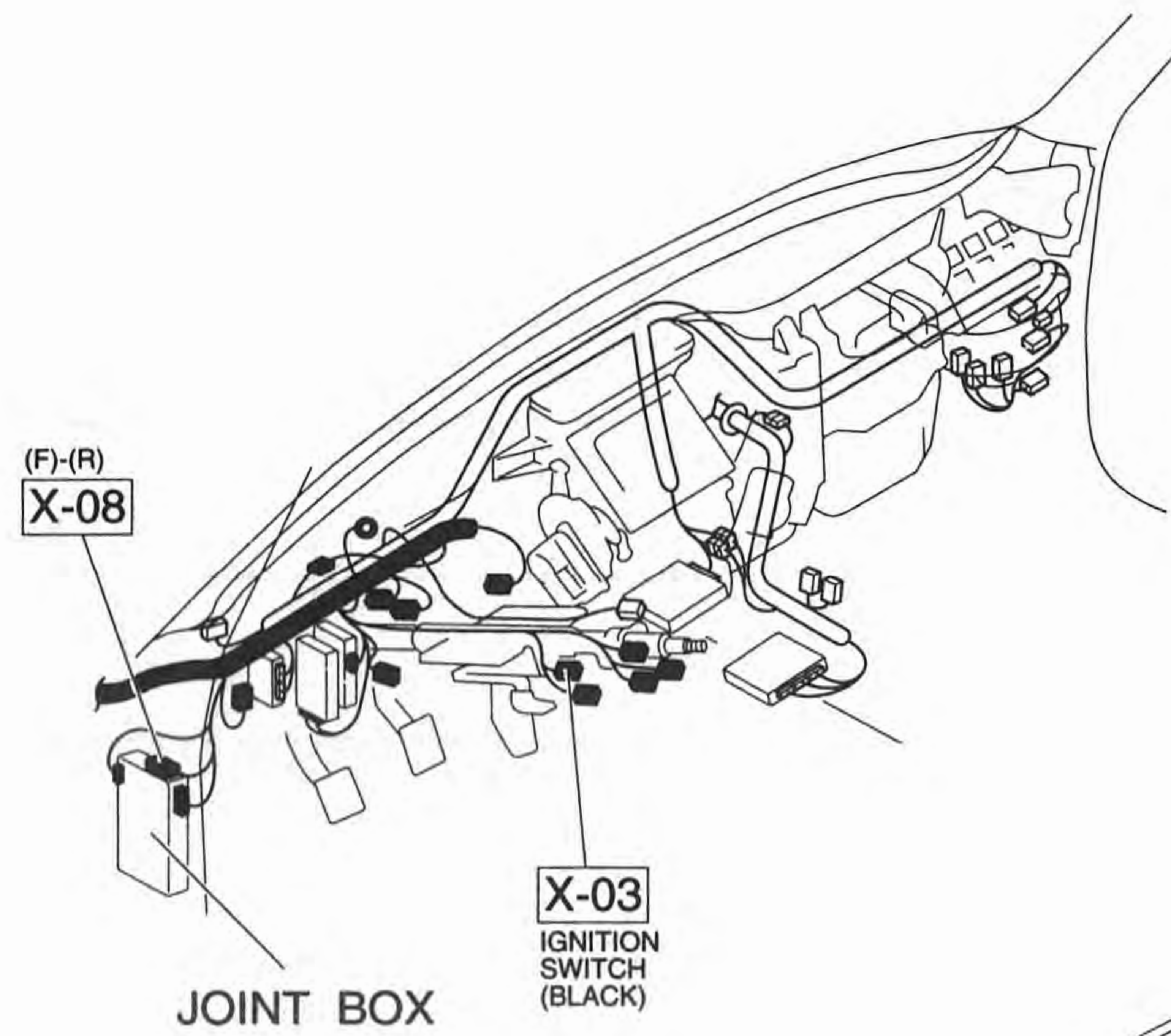
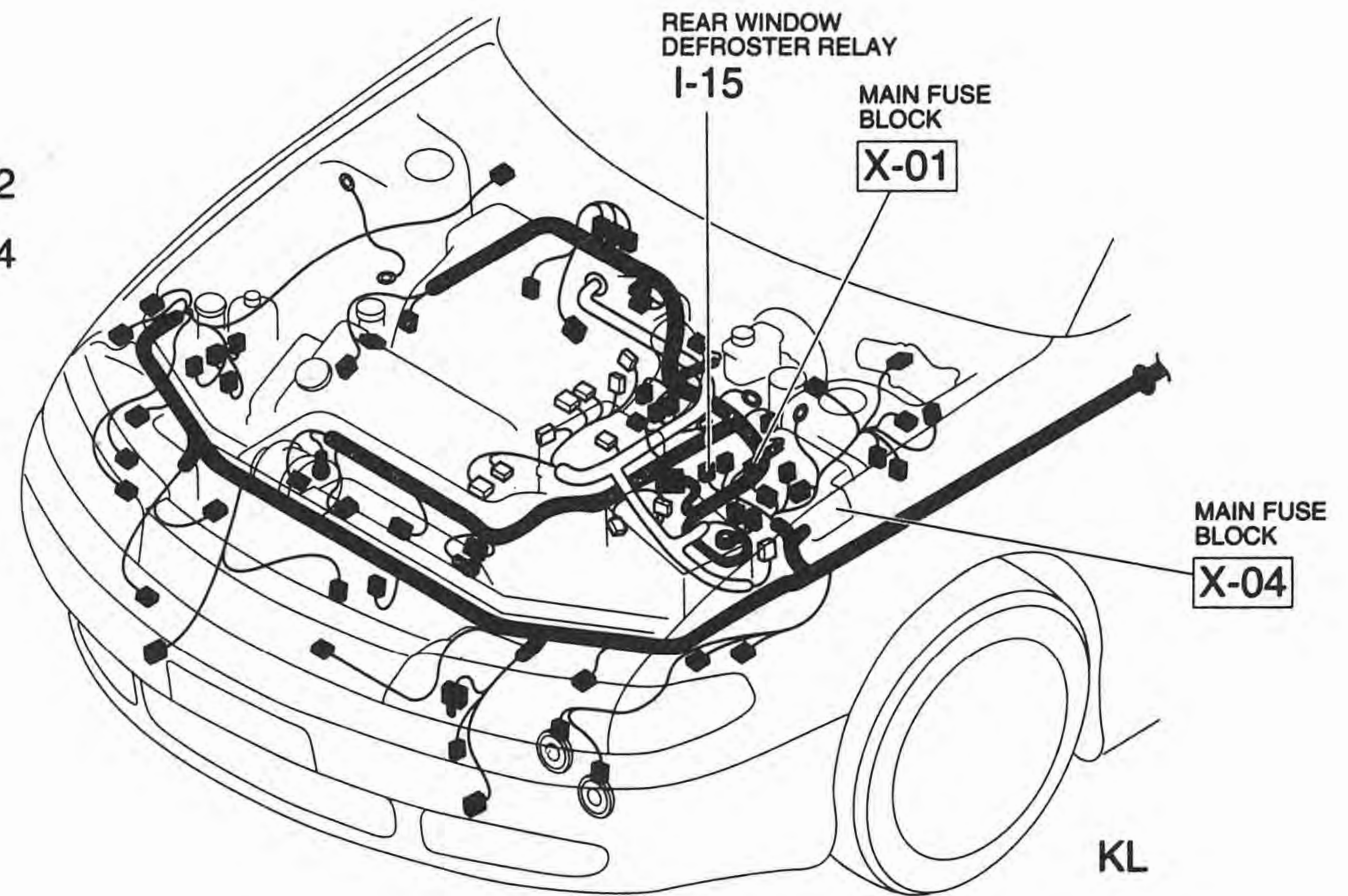
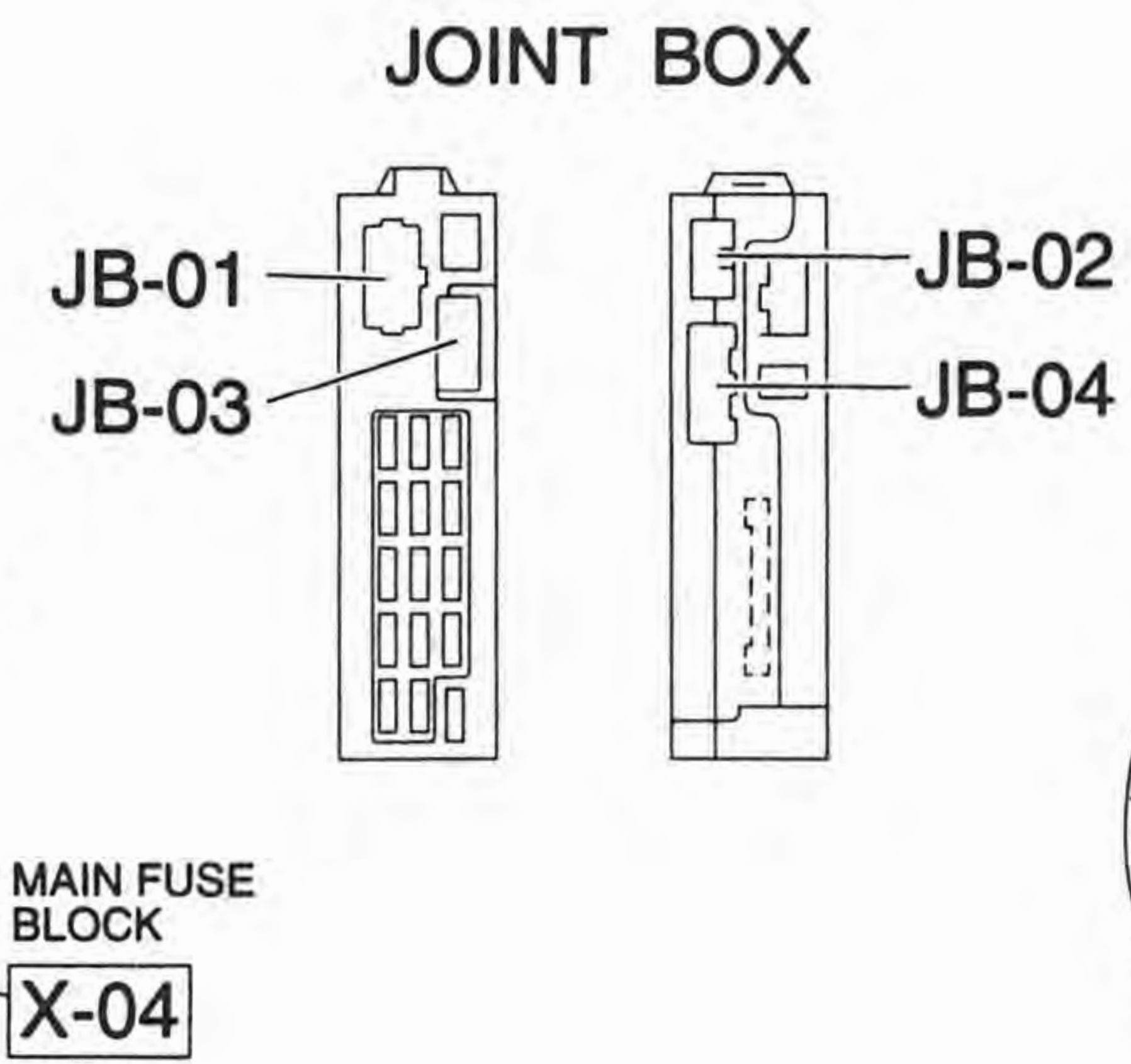
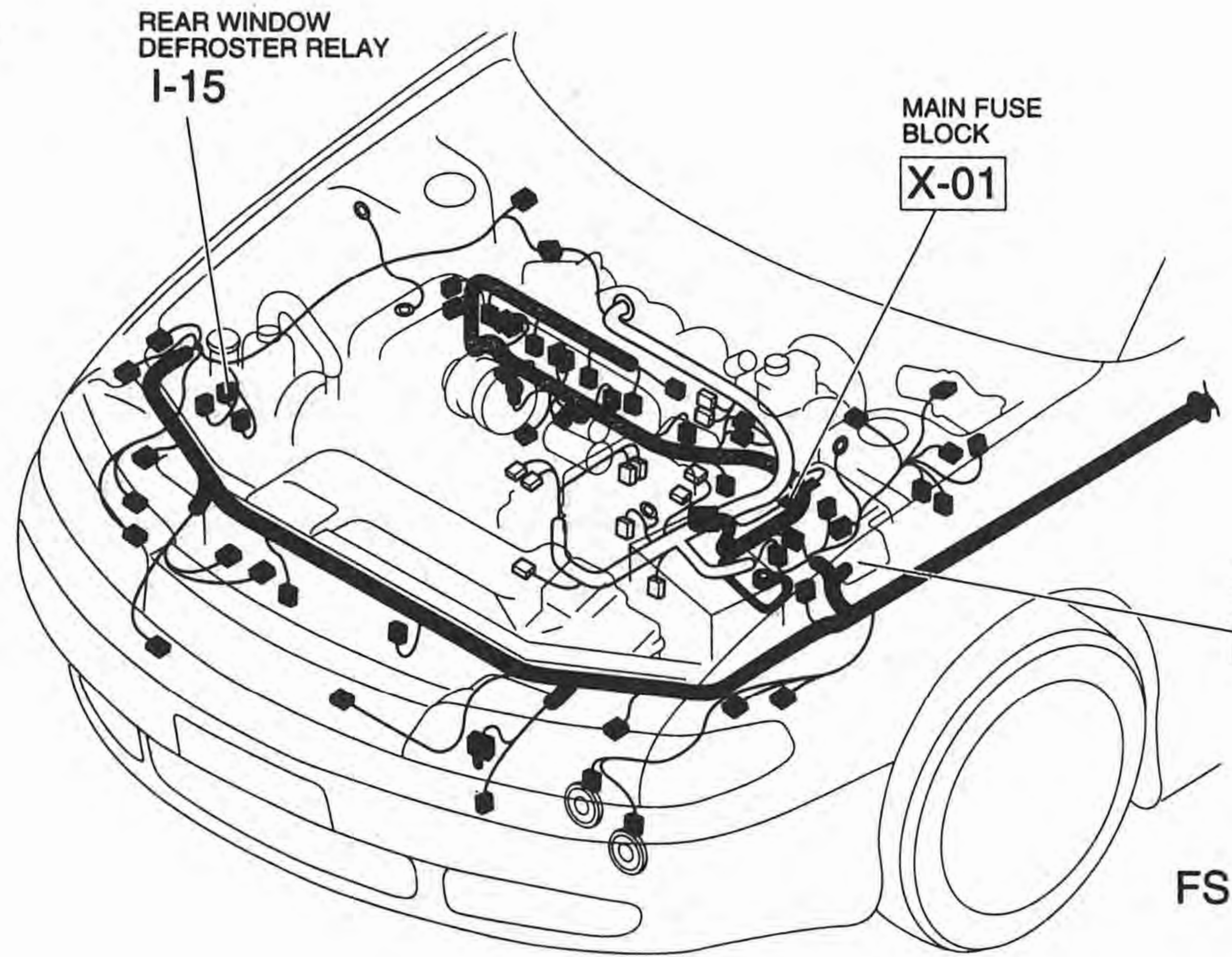

J-1 ■ AUDIO SYSTEM

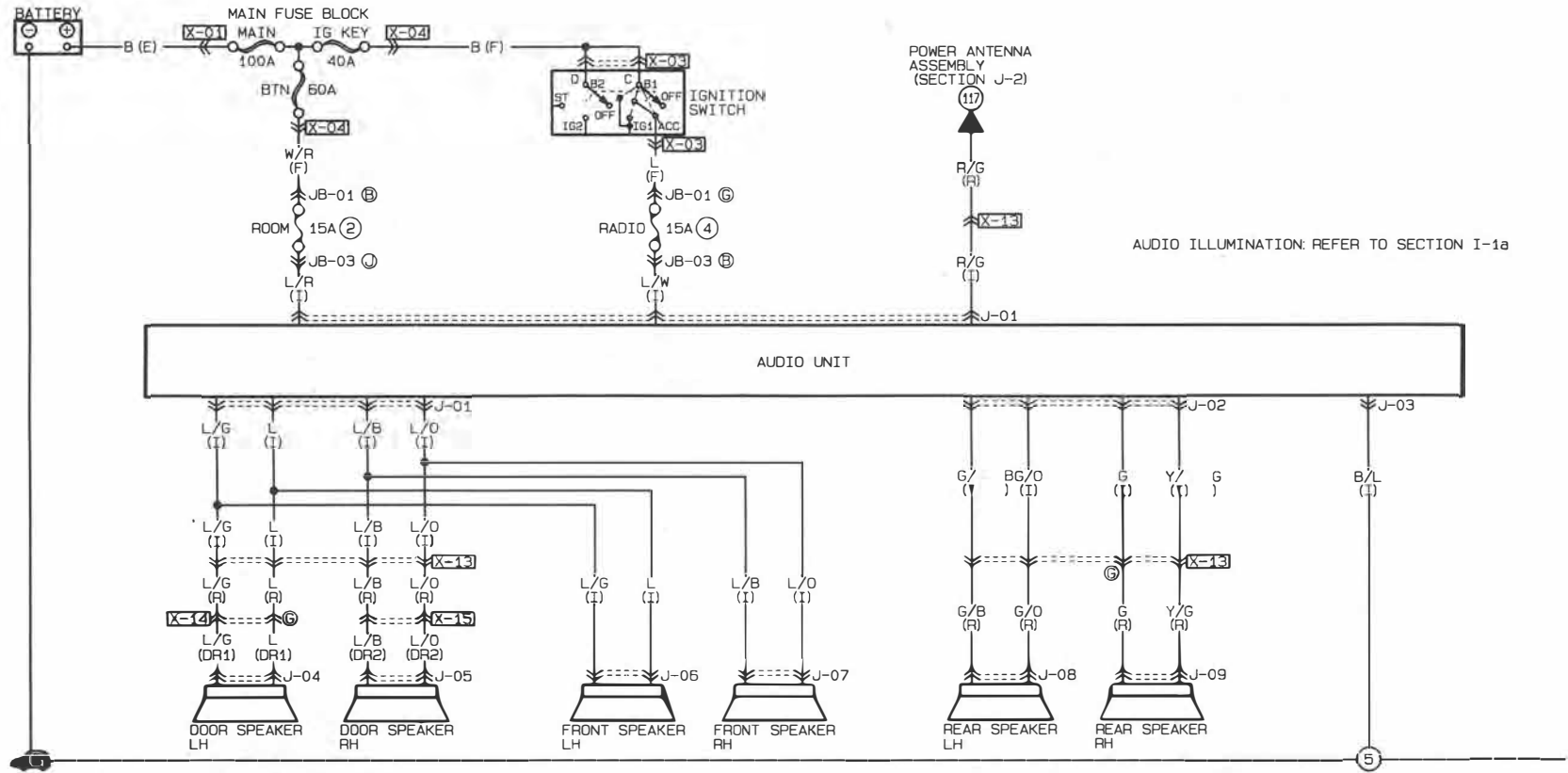

AUDIO ILLUMINATION: REFER TO SECTION I-1a

J-01 AUDIO UNIT (I)



J-02 AUDIO UNIT (I)



J-03 AUDIO UNIT (I)



J-04 DOOR SPEAKER LH (DR1)

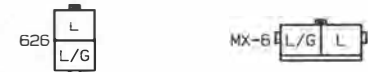

J-05 DOOR SPEAKER RH (DR2)



J-06 FRONT SPEAKER LH (I)

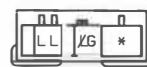

J-07 FRONT SPEAKER RH (I)

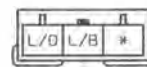

J-08 REAR SPEAKER LH (R)



J-09 REAR SPEAKER RH (R)



J-1

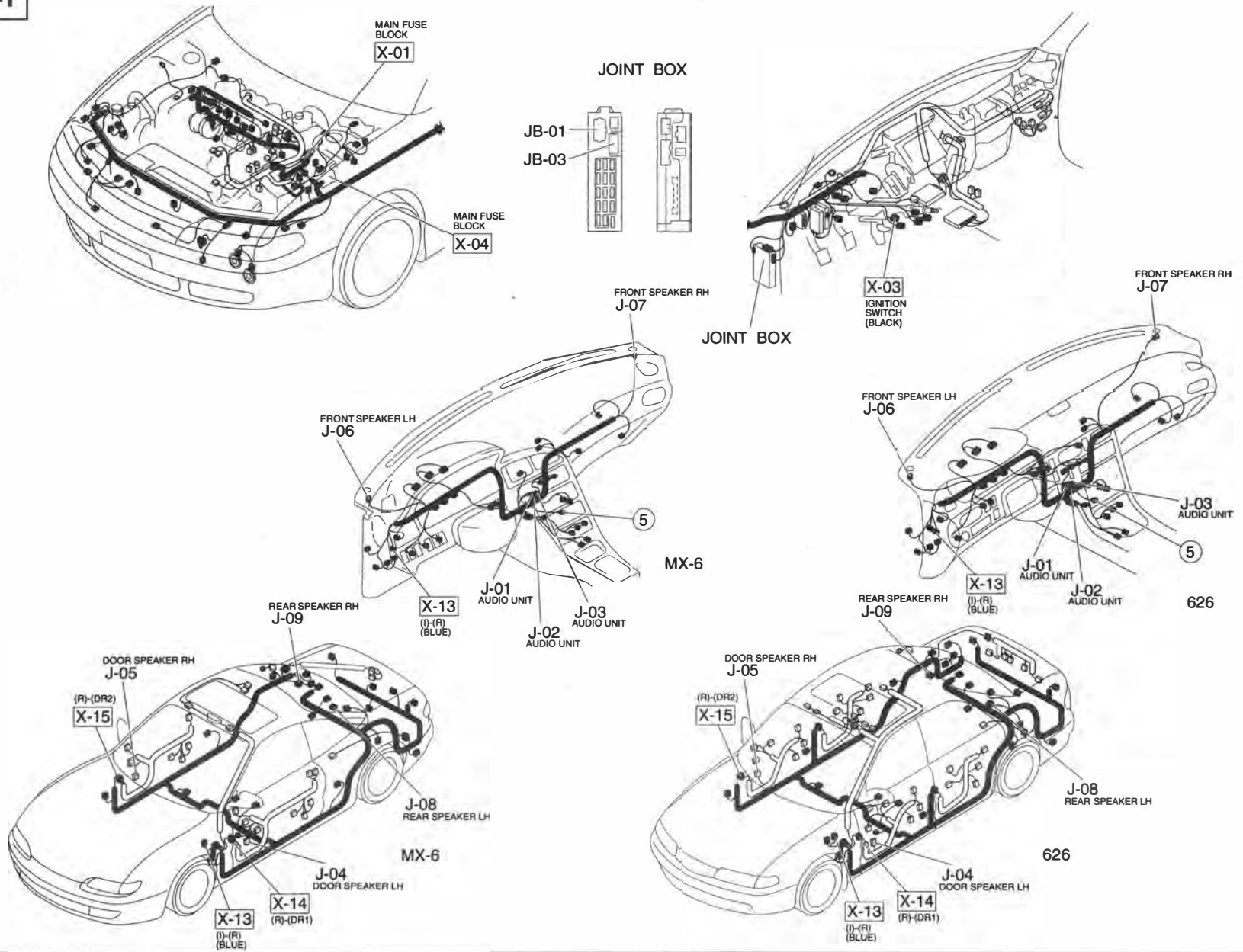

J-2 ■ POWER ANTENNA

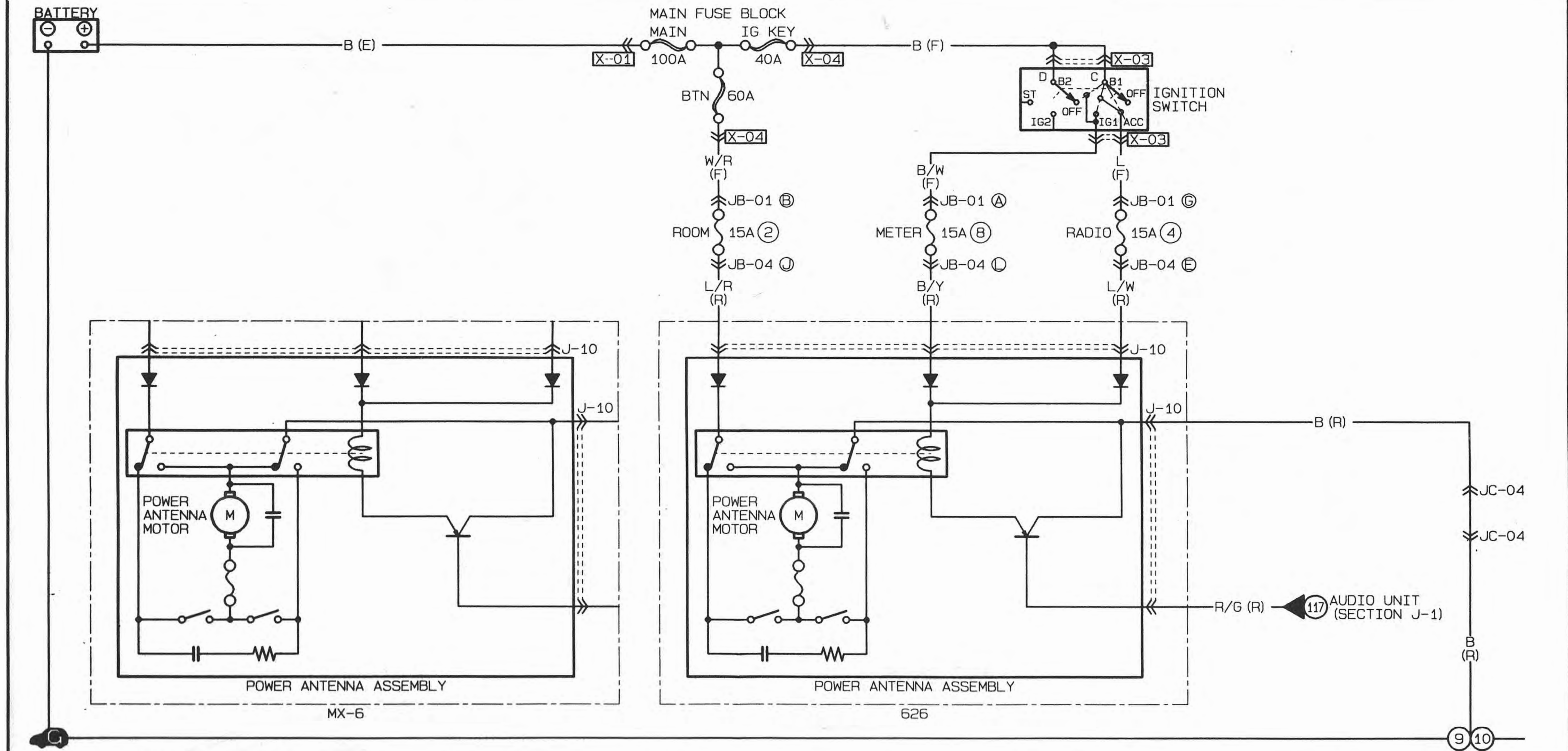

J-10 POWER ANTENNA ASSEMBLY (R)

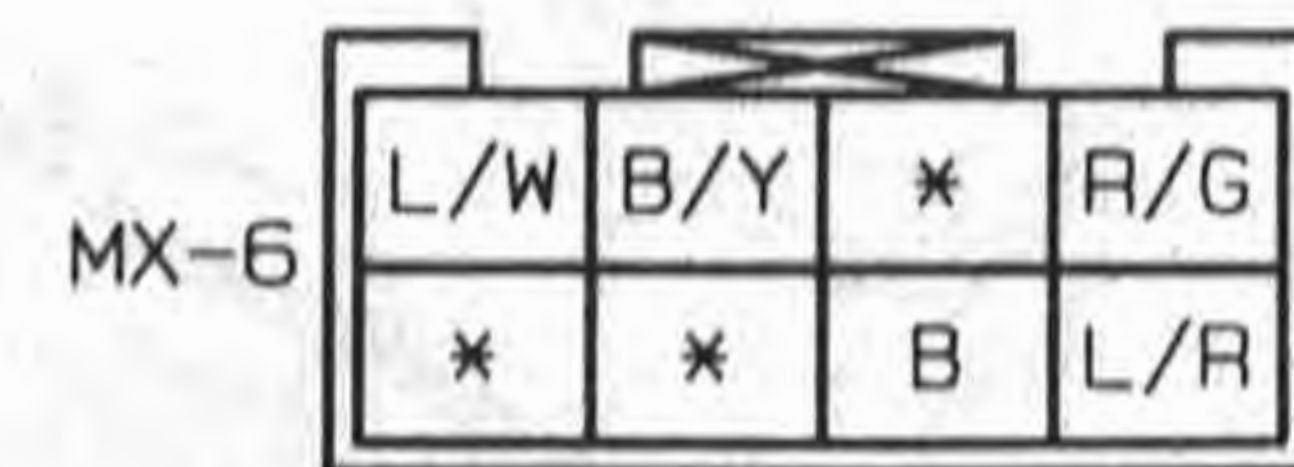

J-2

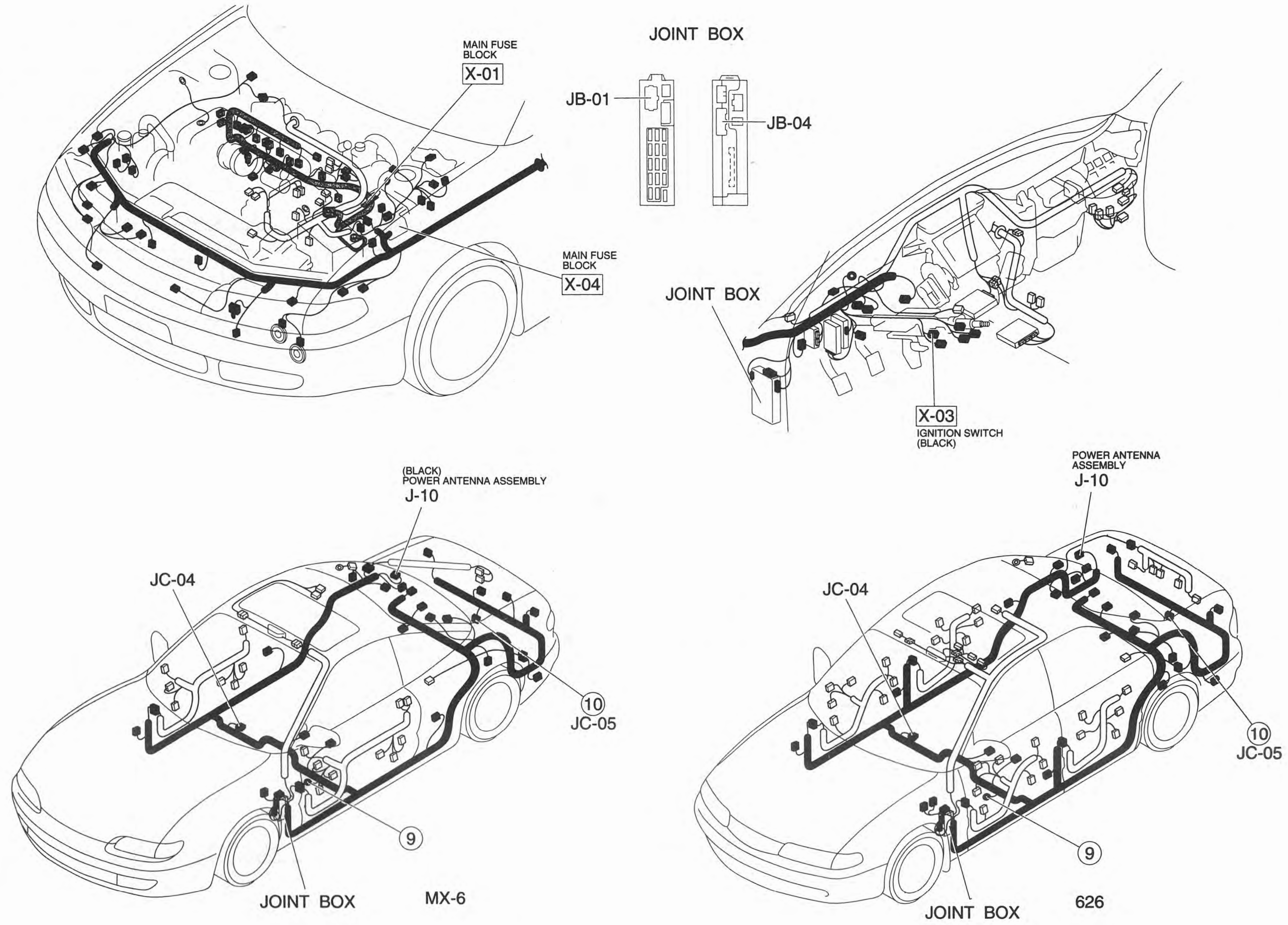

Z WIRING DIAGRAM

K-1 626 ■ POWER WINDOWS

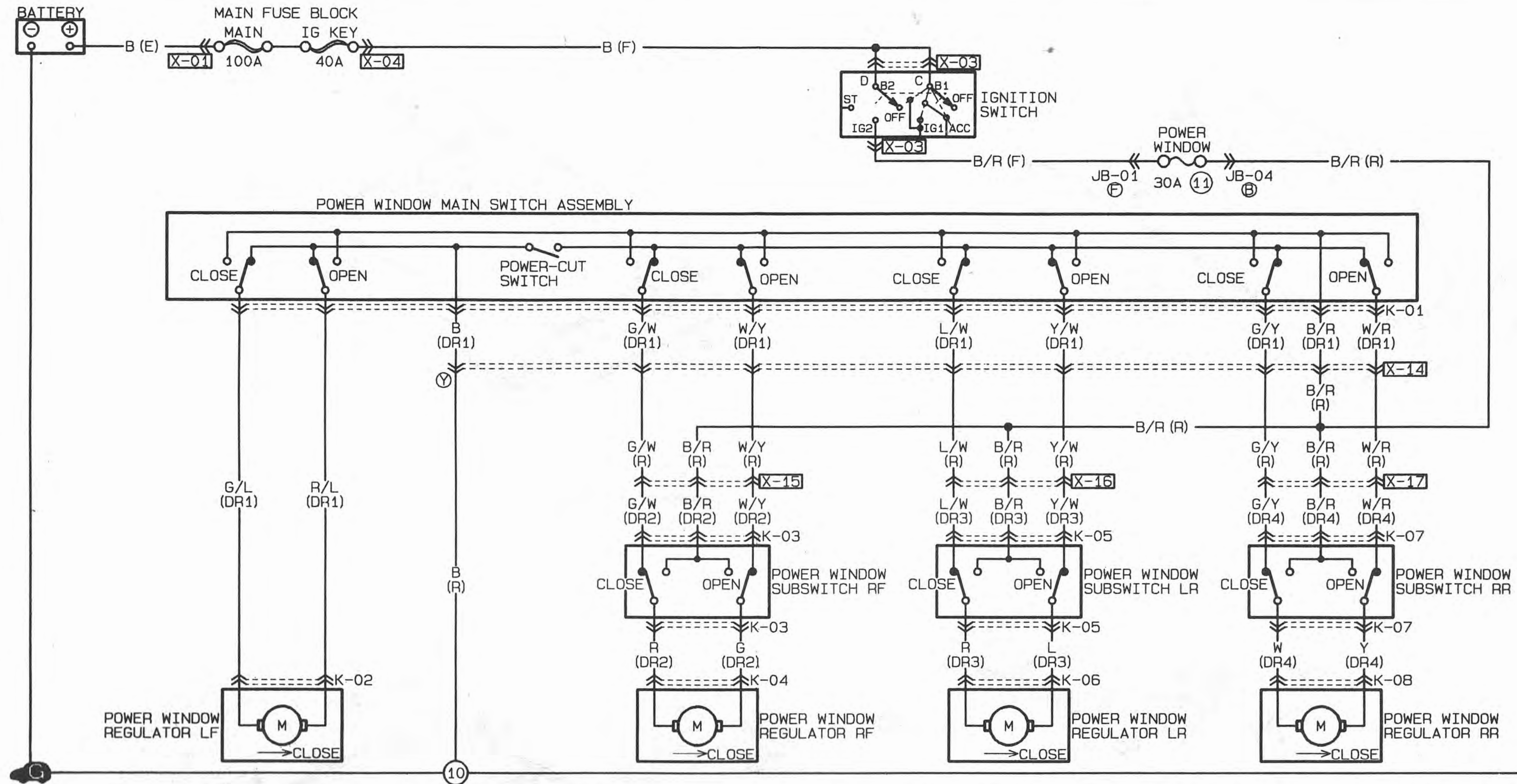

<p>K-01 POWER WINDOW MAIN SWITCH ASSEMBLY (DR1)</p> <table border="1"> <tr> <td>L/W</td> <td>Y/W</td> <td>G/Y</td> <td>W/R</td> <td>B/R</td> </tr> <tr> <td>G/L</td> <td>R/L</td> <td>B</td> <td>*</td> <td>G/W</td> <td>W/Y</td> </tr> </table>	L/W	Y/W	G/Y	W/R	B/R	G/L	R/L	B	*	G/W	W/Y	<p>K-02 POWER WINDOW REGULATOR LF (DR1)</p> <table border="1"> <tr> <td>G/L</td> </tr> <tr> <td>R/L</td> </tr> </table>	G/L	R/L	<p>K-03 POWER WINDOW SUBSWITCH RF (DR2)</p> <table border="1"> <tr> <td>G/W</td> <td>X</td> <td>B/R</td> </tr> <tr> <td>R</td> <td>*</td> <td>W/Y</td> <td>G</td> </tr> </table>	G/W	X	B/R	R	*	W/Y	G	<p>K-04 POWER WINDOW REGULATOR RF (DR2)</p> <table border="1"> <tr> <td>R</td> </tr> <tr> <td>G</td> </tr> </table>	R	G	<p>K-05 POWER WINDOW SUBSWITCH LR (DR3)</p> <table border="1"> <tr> <td>L/W</td> <td>X</td> <td>B/R</td> </tr> <tr> <td>R</td> <td>*</td> <td>Y/W</td> <td>L</td> </tr> </table>	L/W	X	B/R	R	*	Y/W	L	<p>K-06 POWER WINDOW REGULATOR LR (DR3)</p> <table border="1"> <tr> <td>R</td> </tr> <tr> <td>L</td> </tr> </table>	R	L
L/W	Y/W	G/Y	W/R	B/R																																
G/L	R/L	B	*	G/W	W/Y																															
G/L																																				
R/L																																				
G/W	X	B/R																																		
R	*	W/Y	G																																	
R																																				
G																																				
L/W	X	B/R																																		
R	*	Y/W	L																																	
R																																				
L																																				
<p>K-07 POWER WINDOW SUBSWITCH RR (DR4)</p> <table border="1"> <tr> <td>G/Y</td> <td>X</td> <td>B/R</td> </tr> <tr> <td>W</td> <td>*</td> <td>W/R</td> <td>Y</td> </tr> </table>	G/Y	X	B/R	W	*	W/R	Y	<p>K-08 POWER WINDOW REGULATOR RR (DR4)</p> <table border="1"> <tr> <td>W</td> </tr> <tr> <td>Y</td> </tr> </table>	W	Y																										
G/Y	X	B/R																																		
W	*	W/R	Y																																	
W																																				
Y																																				

K-1

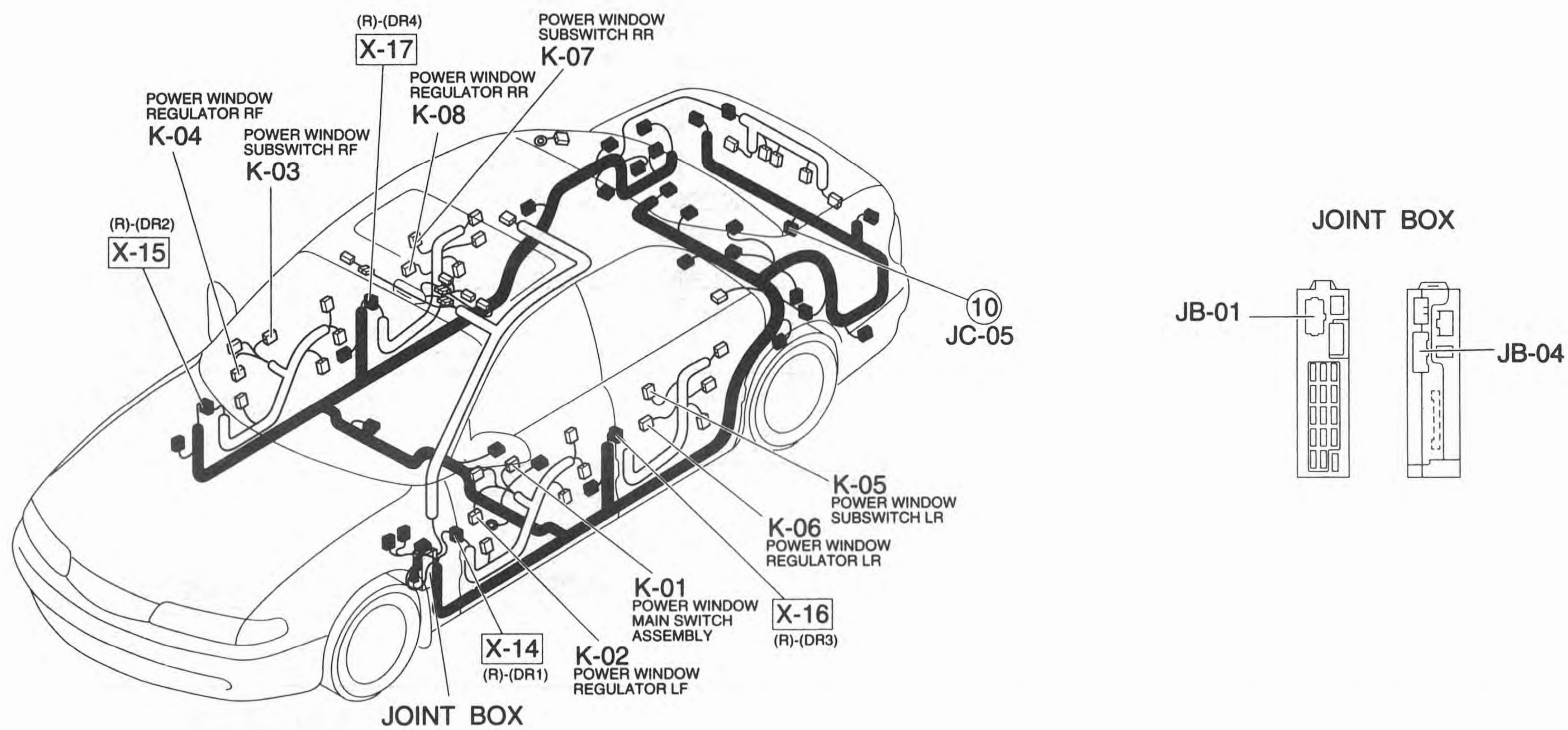
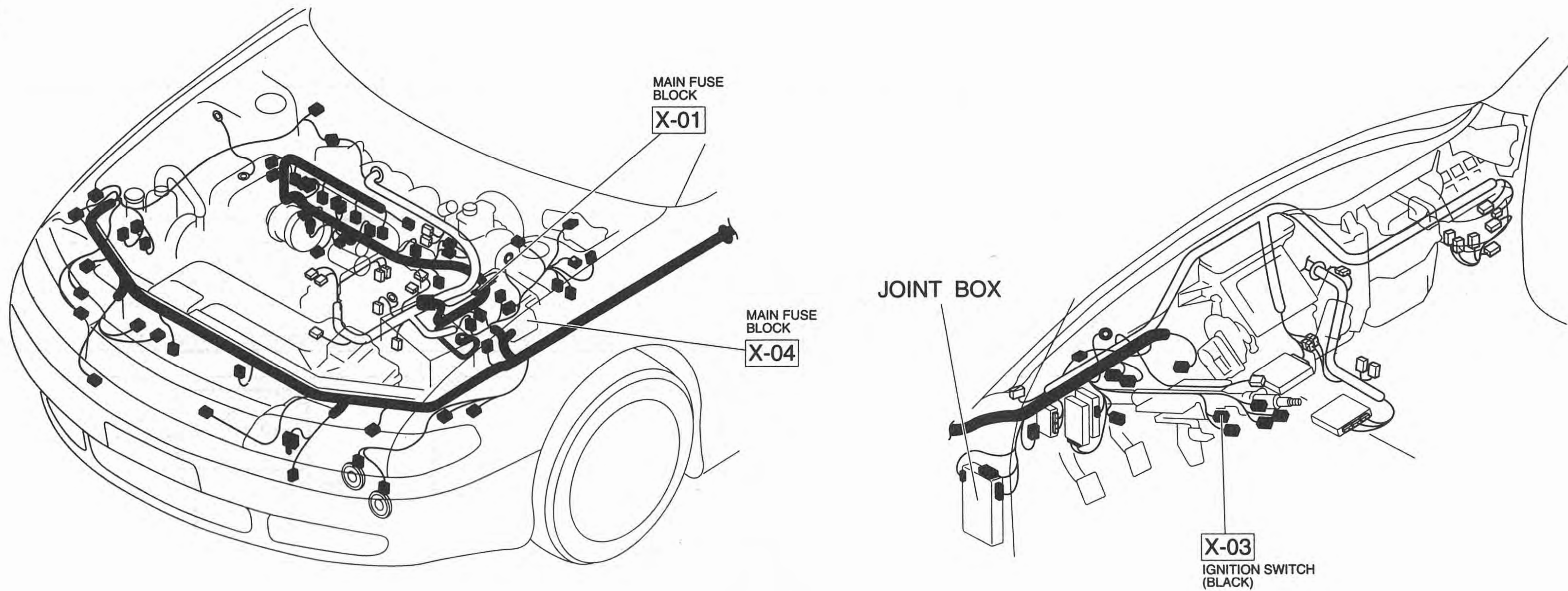

K-2 MX-6 ■ POWER WINDOWS

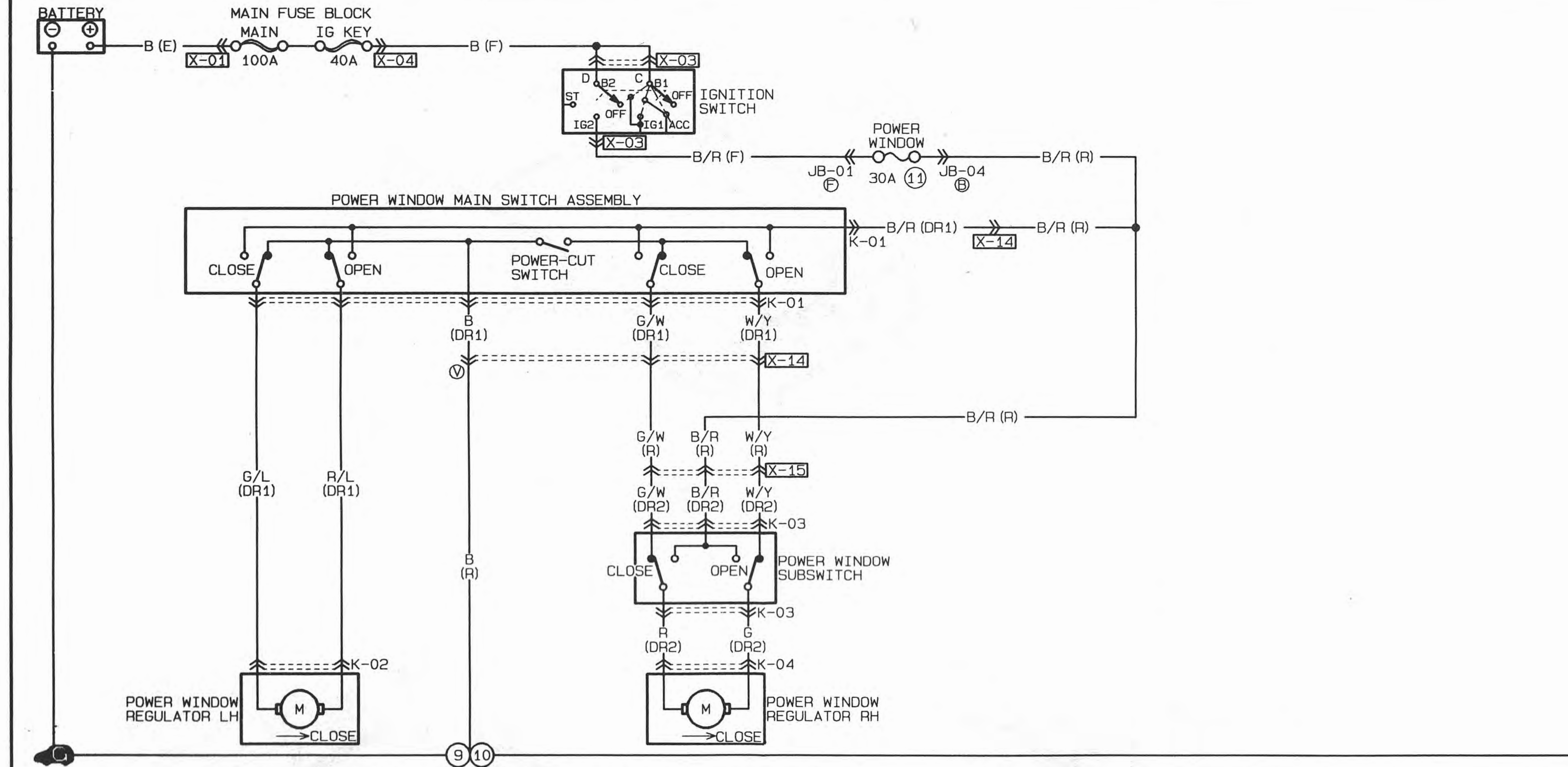

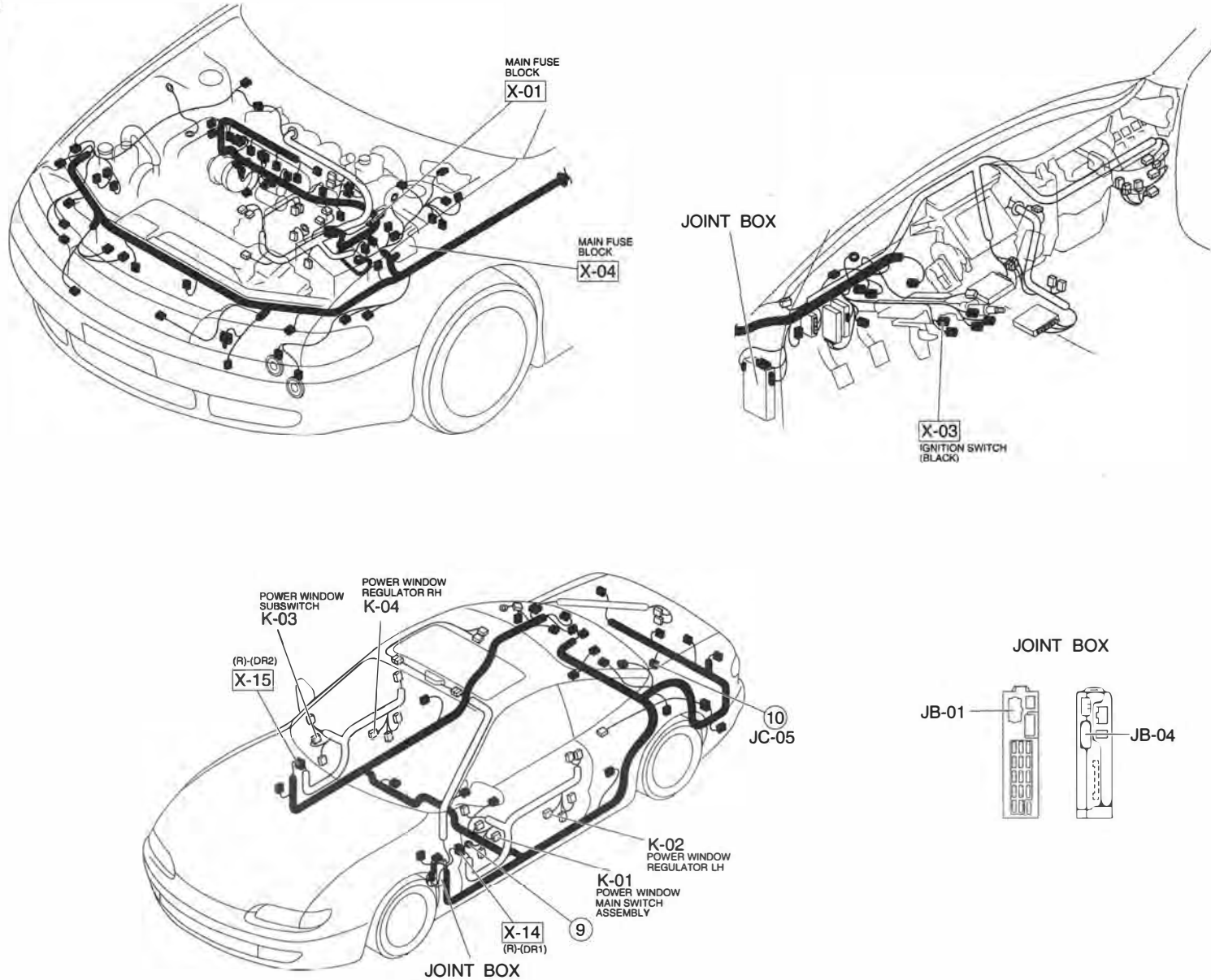

K-01 POWER WINDOW MAIN SWITCH ASSEMBLY (DR1)	K-02 POWER WINDOW REGULATOR LH (DR1)	K-03 POWER WINDOW SUBSWITCH (DR2)	K-04 POWER WINDOW REGULATOR RH (DR2)																				
<table border="1" style="width: 100%; text-align: center;"> <tr> <td>W/Y</td> <td></td> <td>B</td> <td>R/L</td> </tr> <tr> <td>B/R</td> <td>G/W</td> <td>*</td> <td>* G/L</td> </tr> </table>	W/Y		B	R/L	B/R	G/W	*	* G/L	<table border="1" style="width: 100%; text-align: center;"> <tr> <td>G/L</td> </tr> <tr> <td>R/L</td> </tr> </table>	G/L	R/L	<table border="1" style="width: 100%; text-align: center;"> <tr> <td>G/W</td> <td></td> <td>B/R</td> </tr> <tr> <td>R</td> <td>* W/Y</td> <td>G</td> </tr> </table>	G/W		B/R	R	* W/Y	G	<table border="1" style="width: 100%; text-align: center;"> <tr> <td>R</td> </tr> <tr> <td>G</td> </tr> </table>	R	G		
W/Y		B	R/L																				
B/R	G/W	*	* G/L																				
G/L																							
R/L																							
G/W		B/R																					
R	* W/Y	G																					
R																							
G																							

K-2

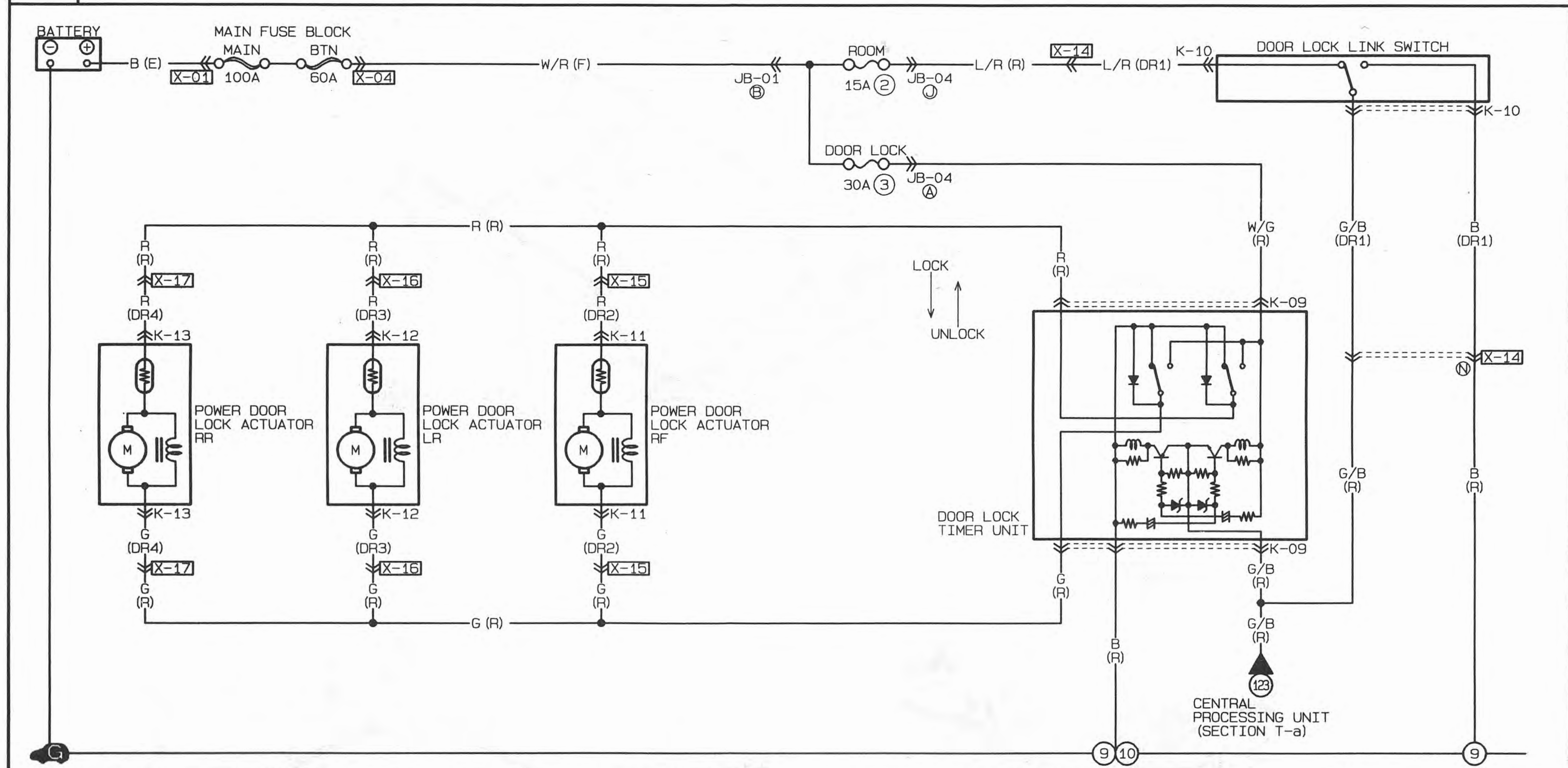



<p>K-09 DOOR LOCK TIMER UNIT (R)</p> <table border="1"> <tr><td>G</td><td>R</td><td>W/G</td></tr> <tr><td>G/B</td><td>*</td><td>B</td></tr> </table>	G	R	W/G	G/B	*	B	<p>K-10 DOOR LOCK LINK SWITCH (DR1)</p> 	<p>K-11 POWER DOOR LOCK ACTUATOR RF (DR2)</p> 	<p>K-12 POWER DOOR LOCK ACTUATOR LR (DR3)</p> <table border="1"> <tr><td>R</td></tr> <tr><td>G</td></tr> </table>	R	G	<p>K-13 POWER DOOR LOCK ACTUATOR RR (DR4)</p> <table border="1"> <tr><td>R</td></tr> <tr><td>G</td></tr> </table>	R	G		
G	R	W/G														
G/B	*	B														
R																
G																
R																
G																

K-3

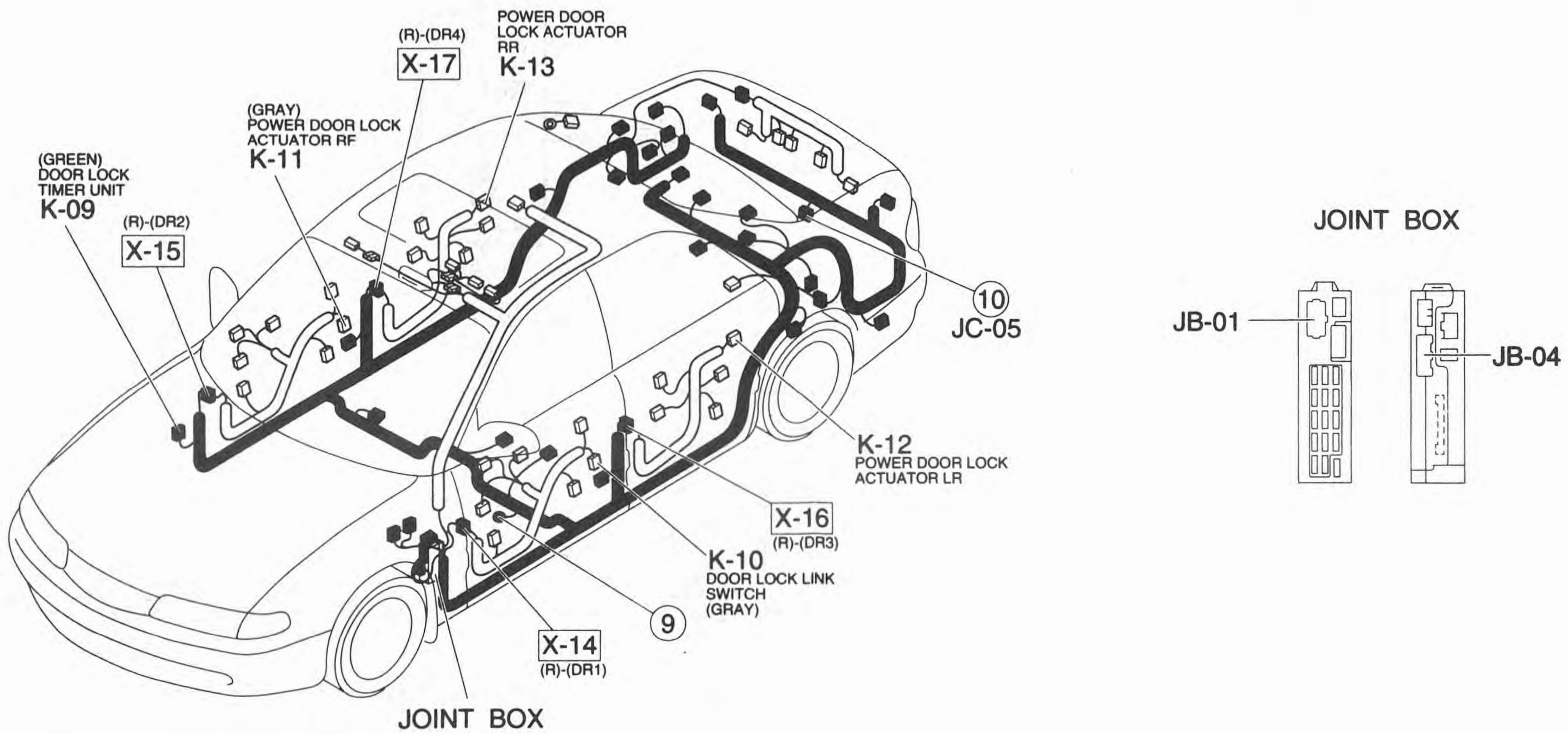
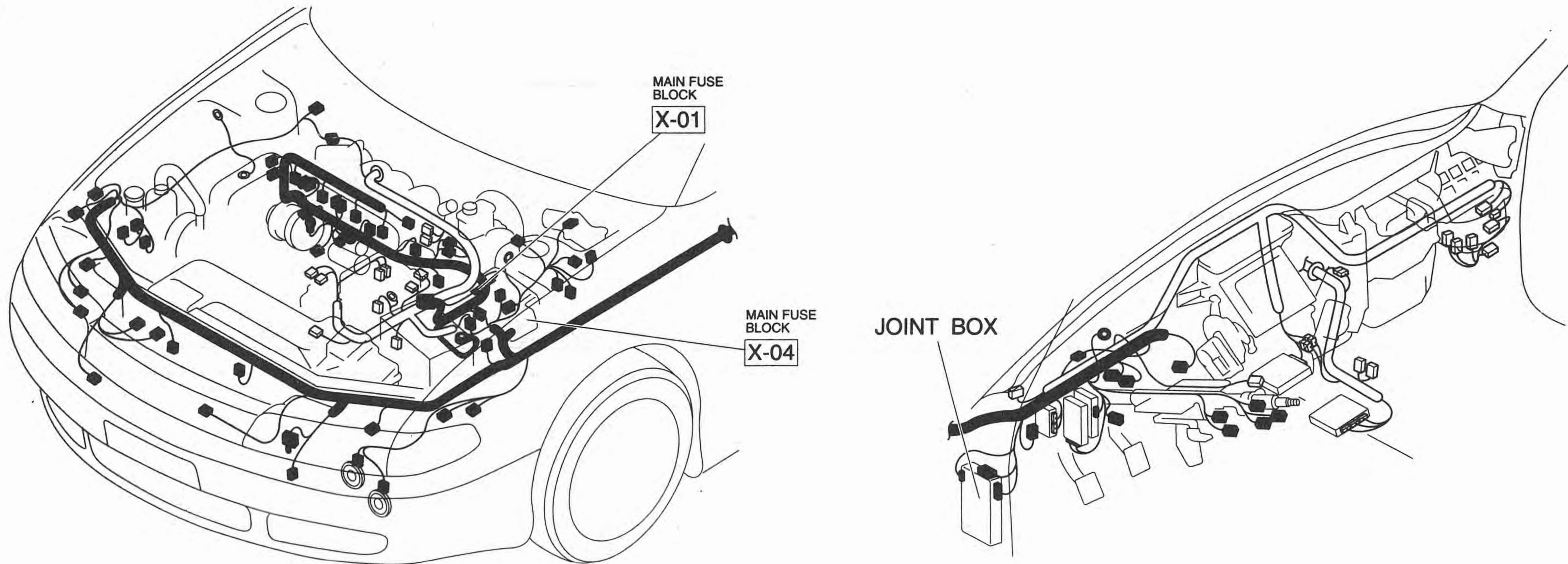

K-4 MX-6 ■ POWER DOOR LOCKS

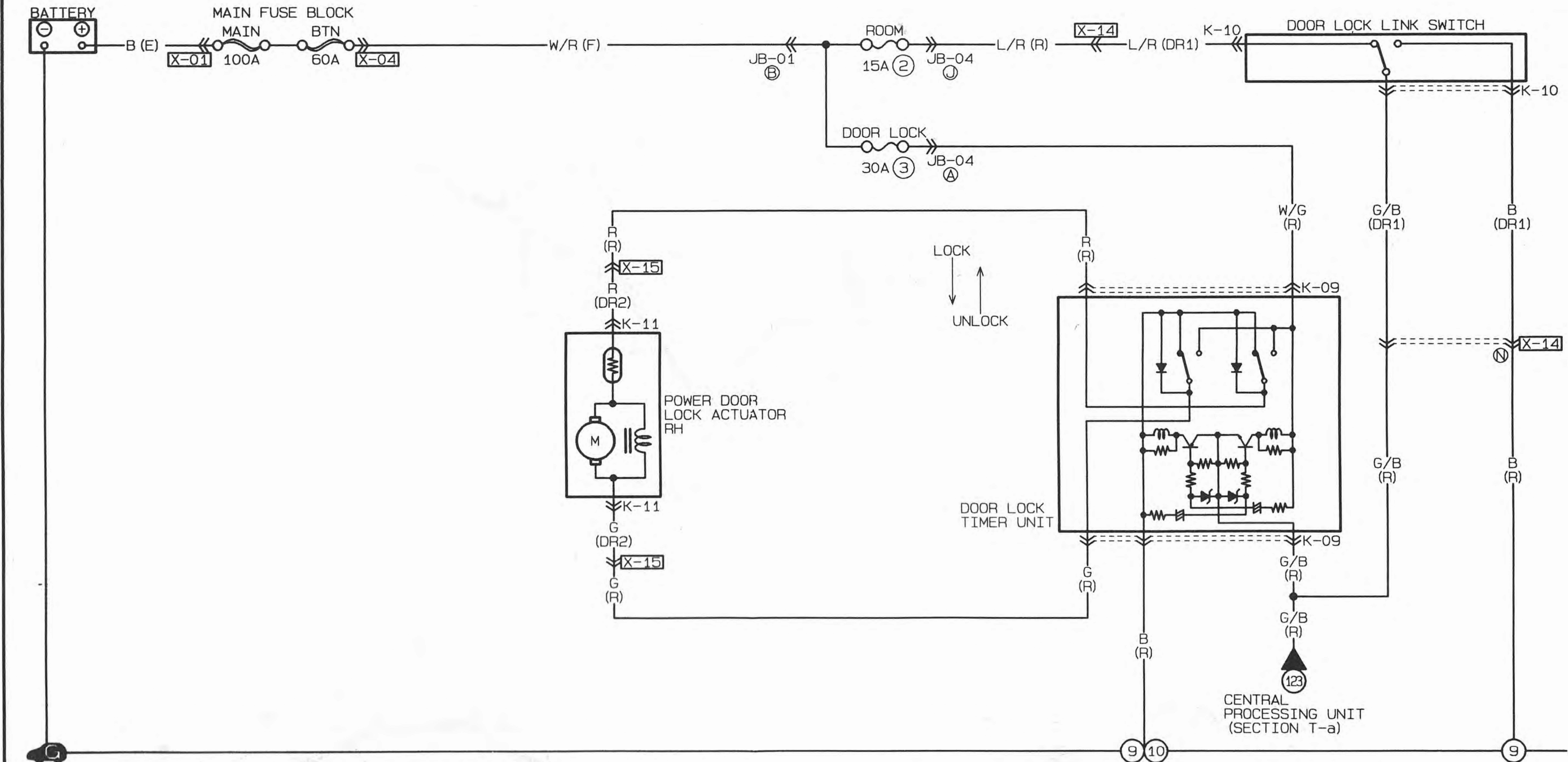

K-09 DOOR LOCK TIMER UNIT (R)

G	R	W/G
G/B	*	B

K-10 DOOR LOCK LINK SWITCH (DR1)



K-11 POWER DOOR LOCK ACTUATOR RH (DR2)



K-4

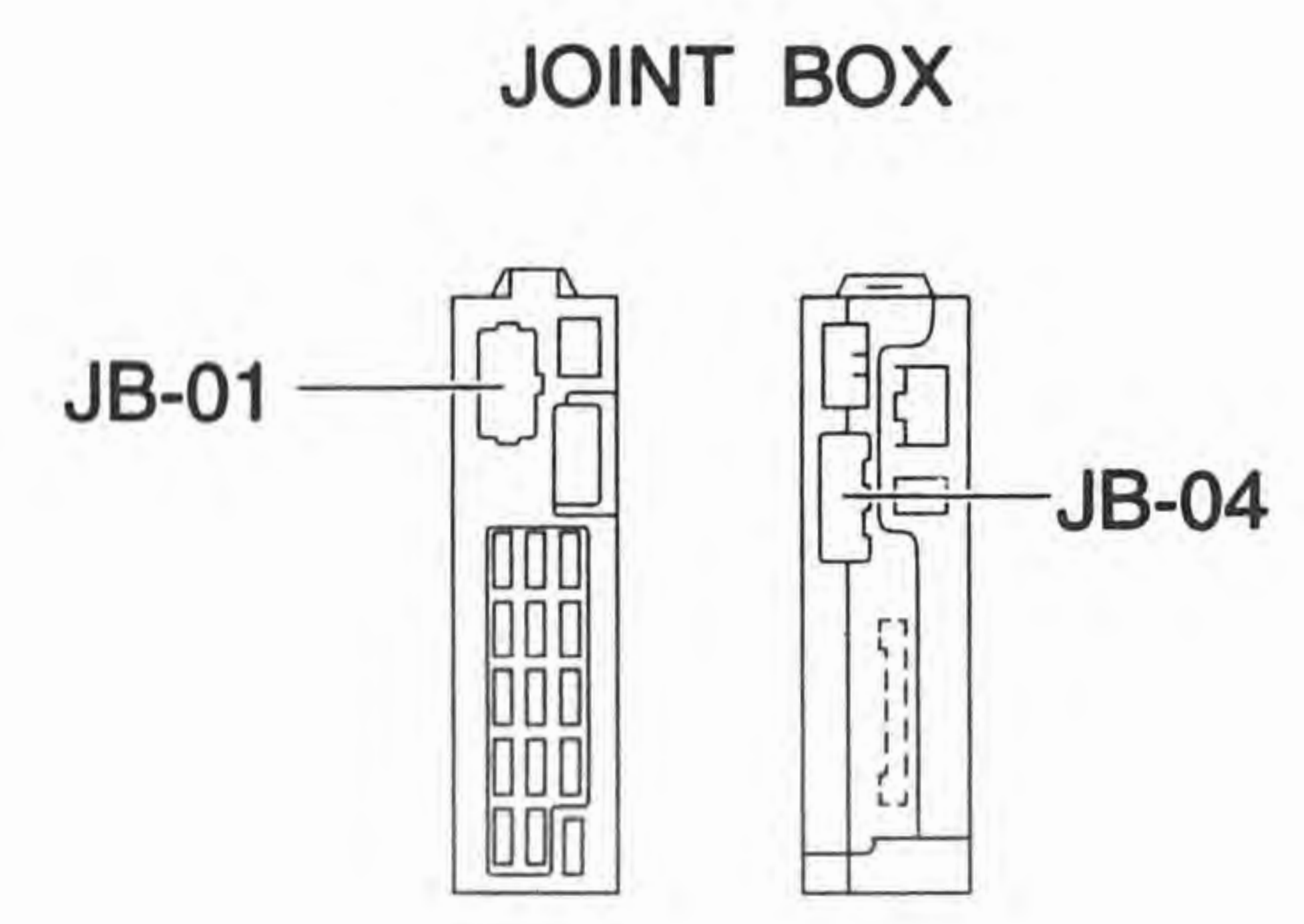
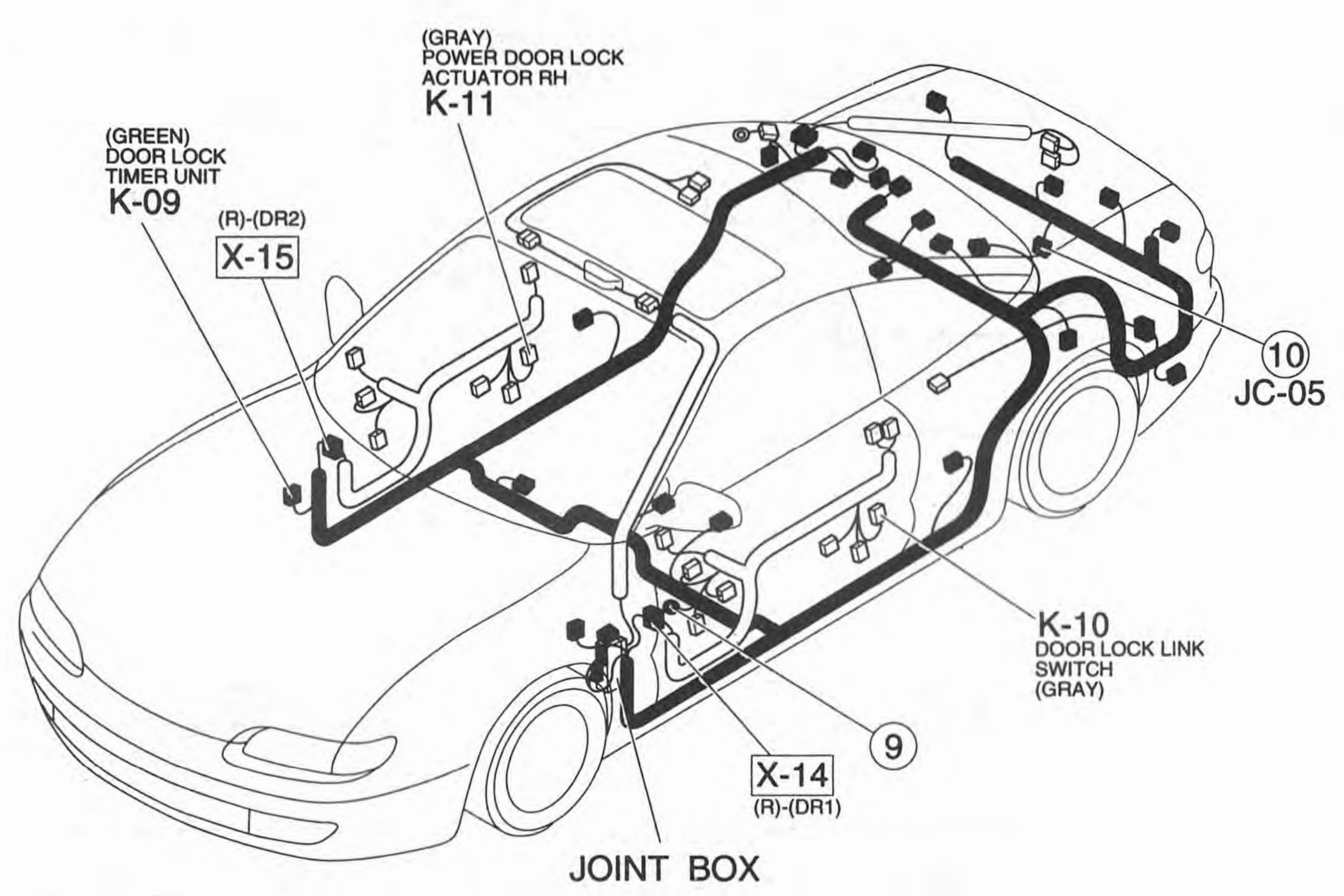
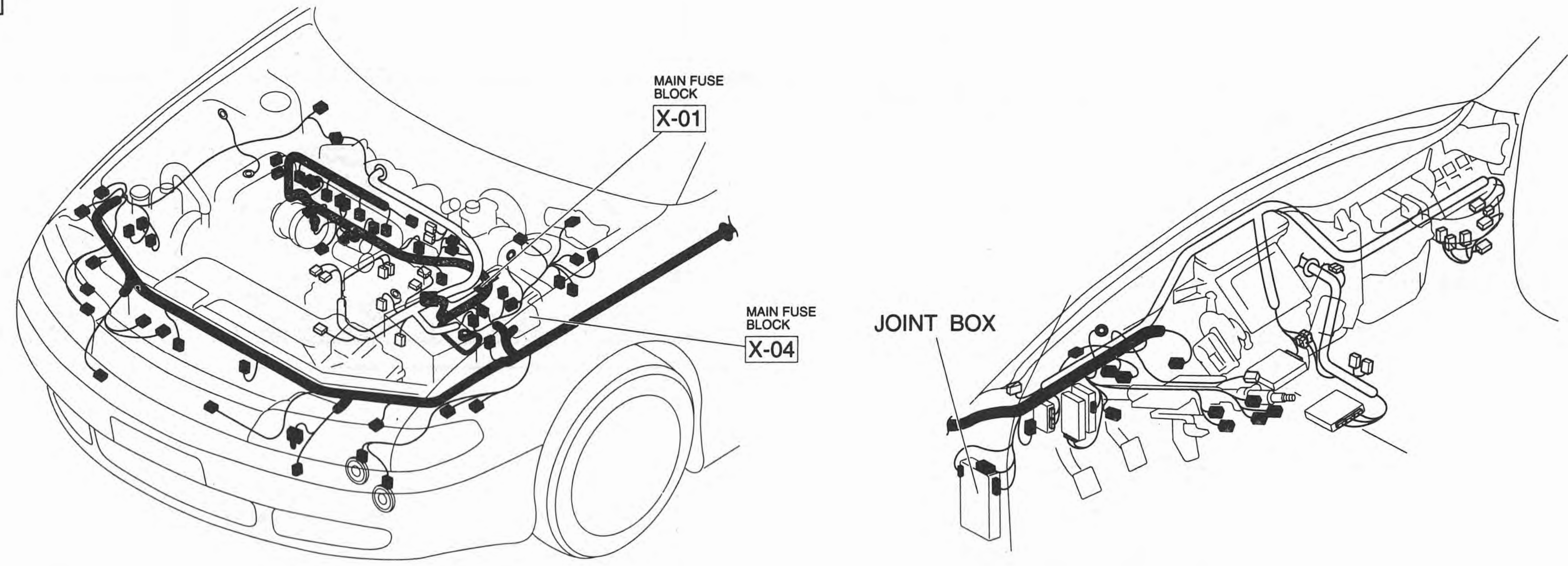

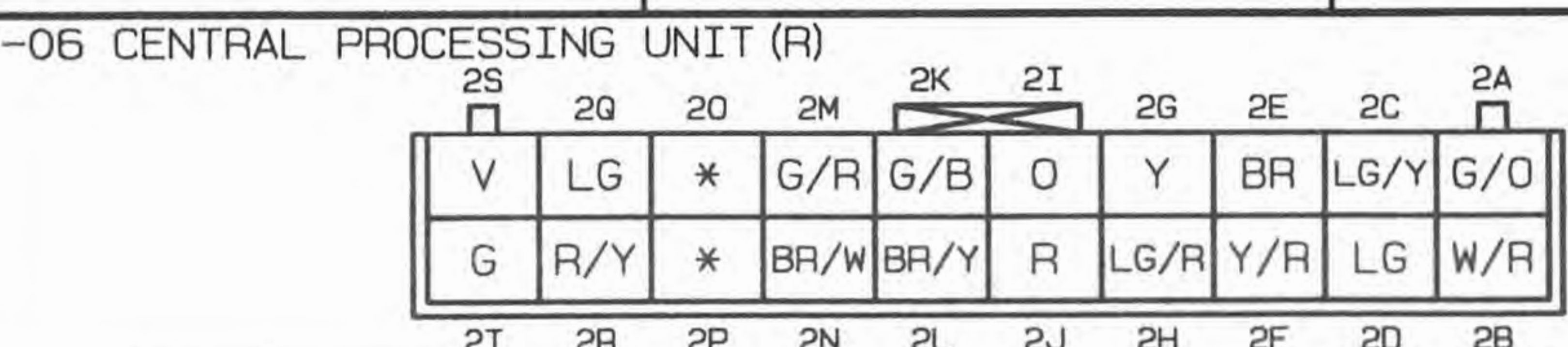
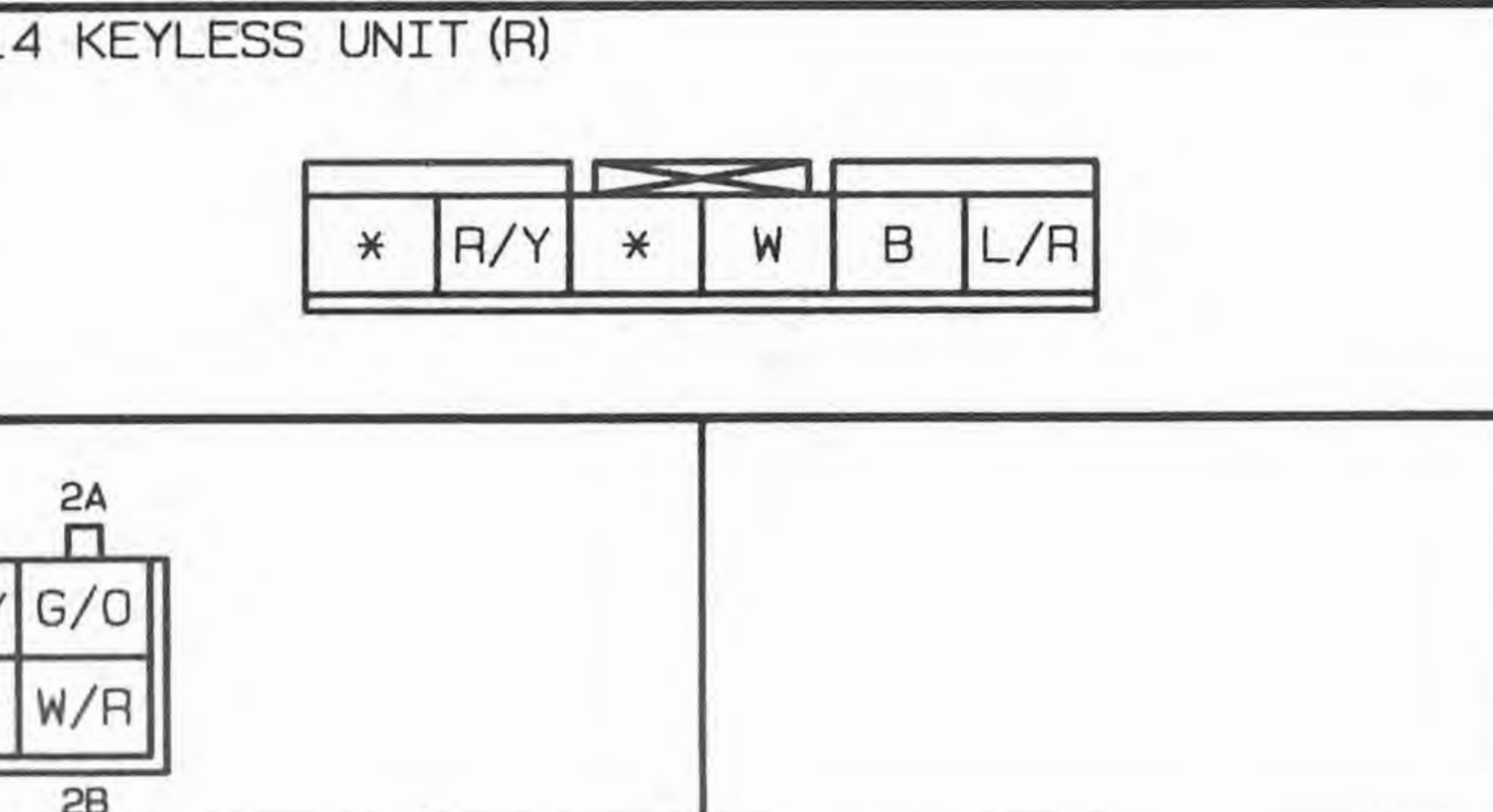
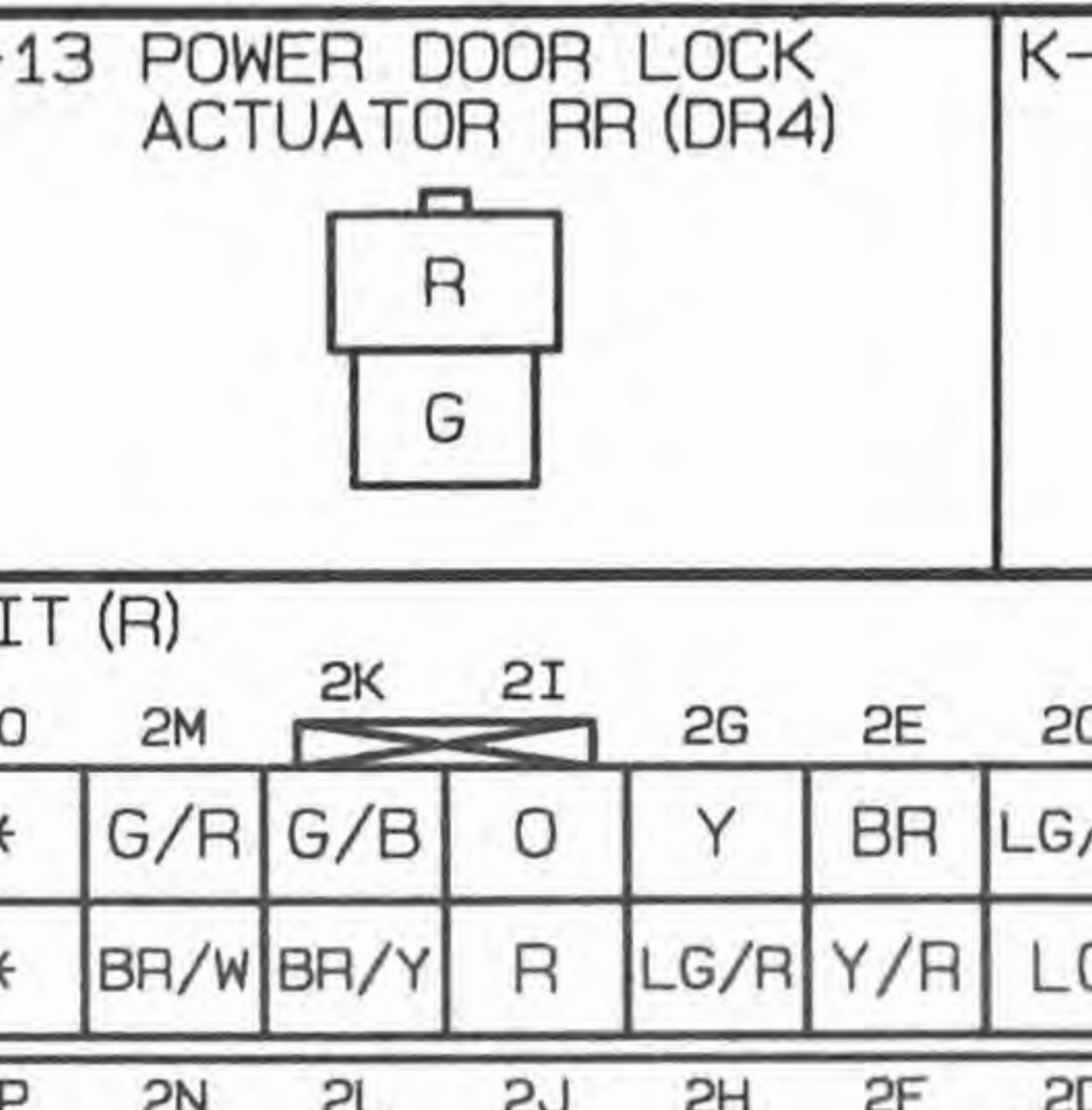
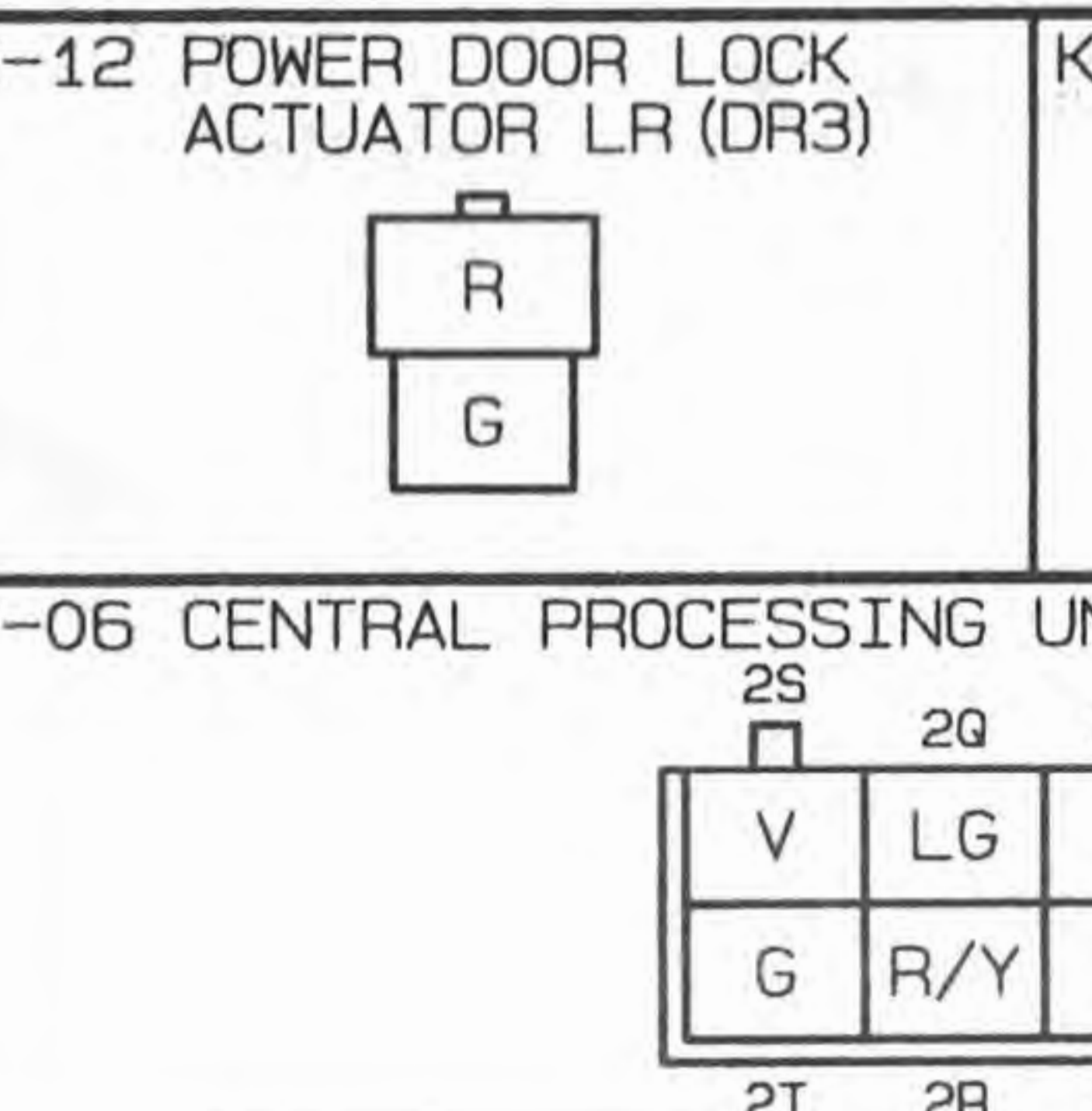
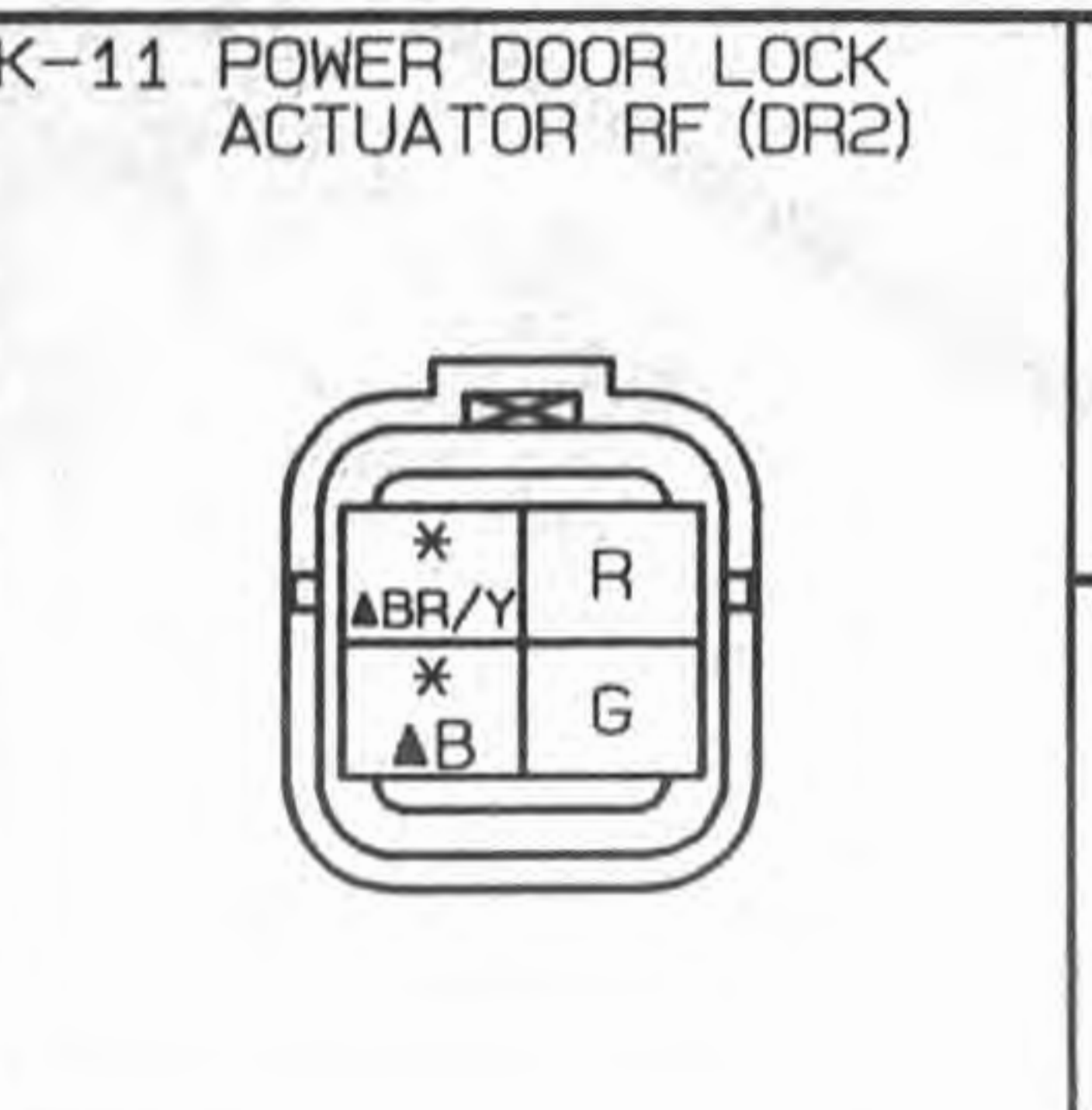
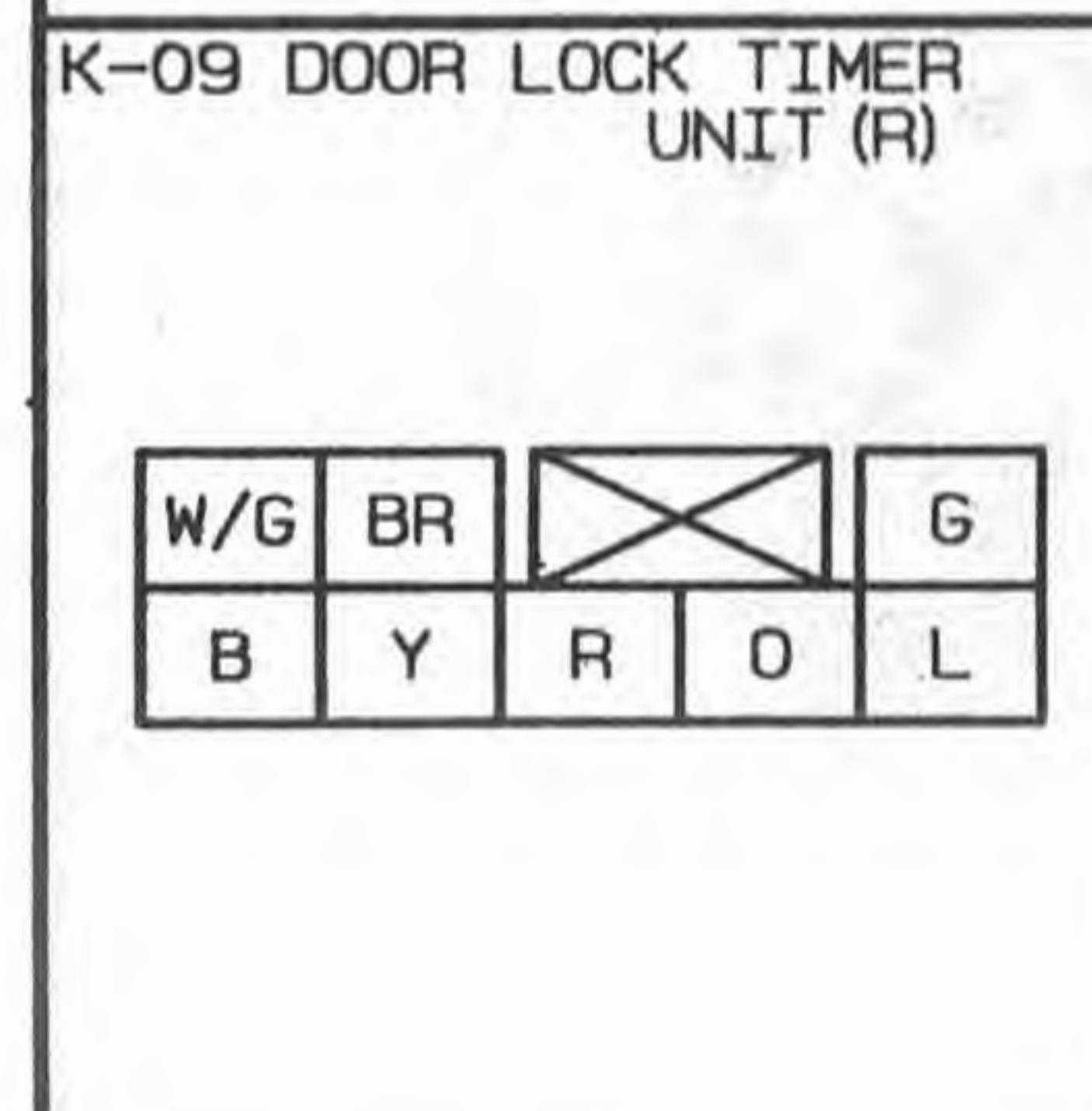
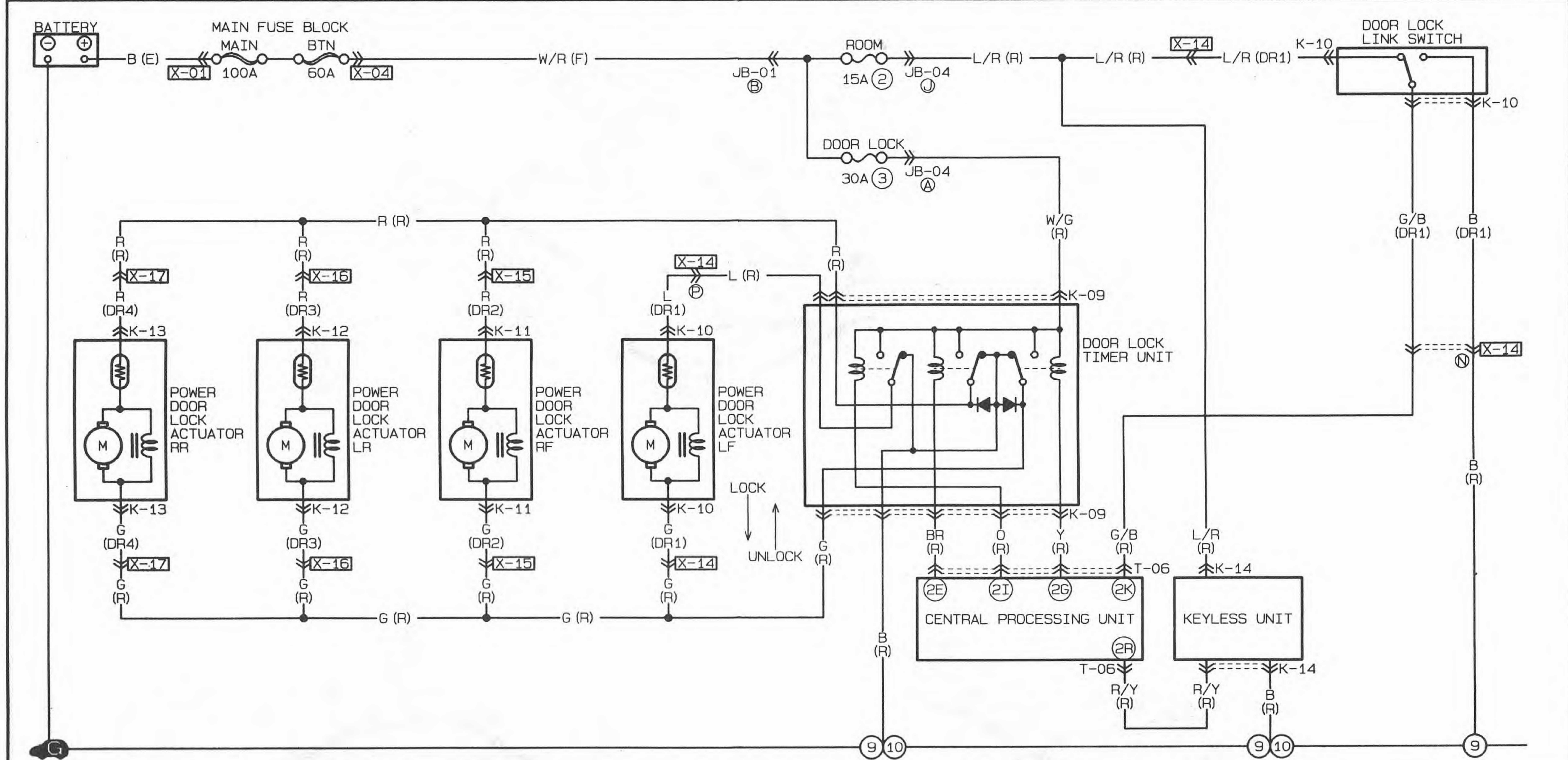

K-5

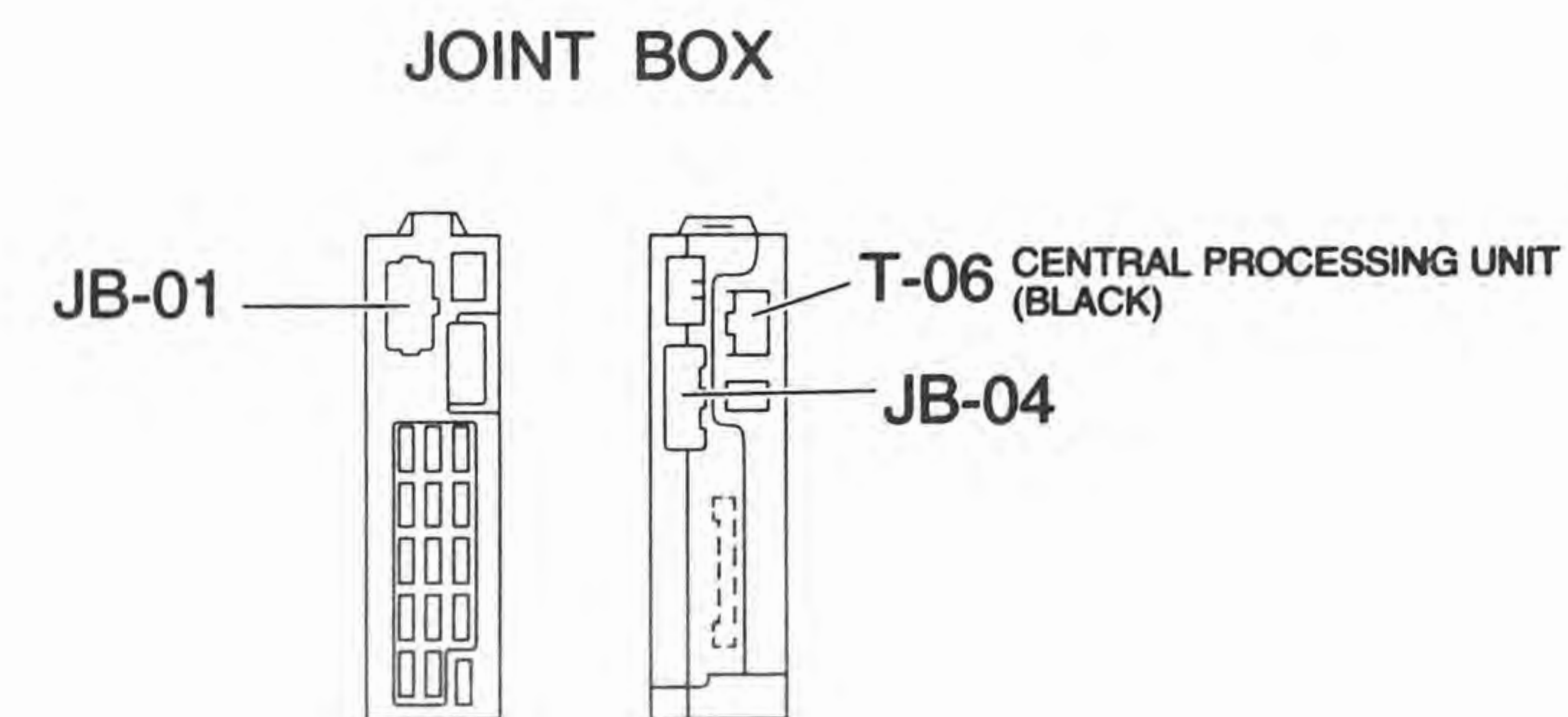
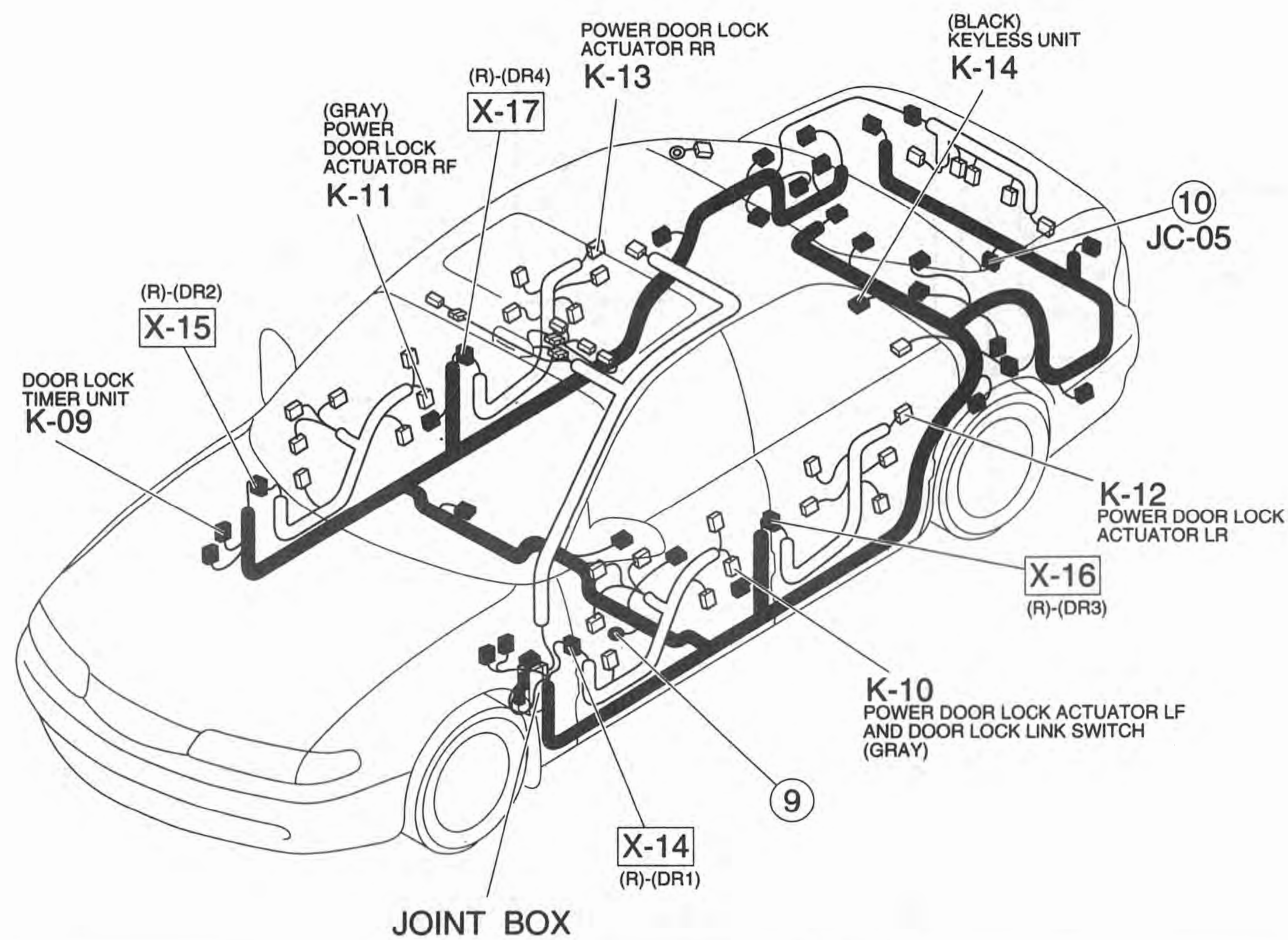
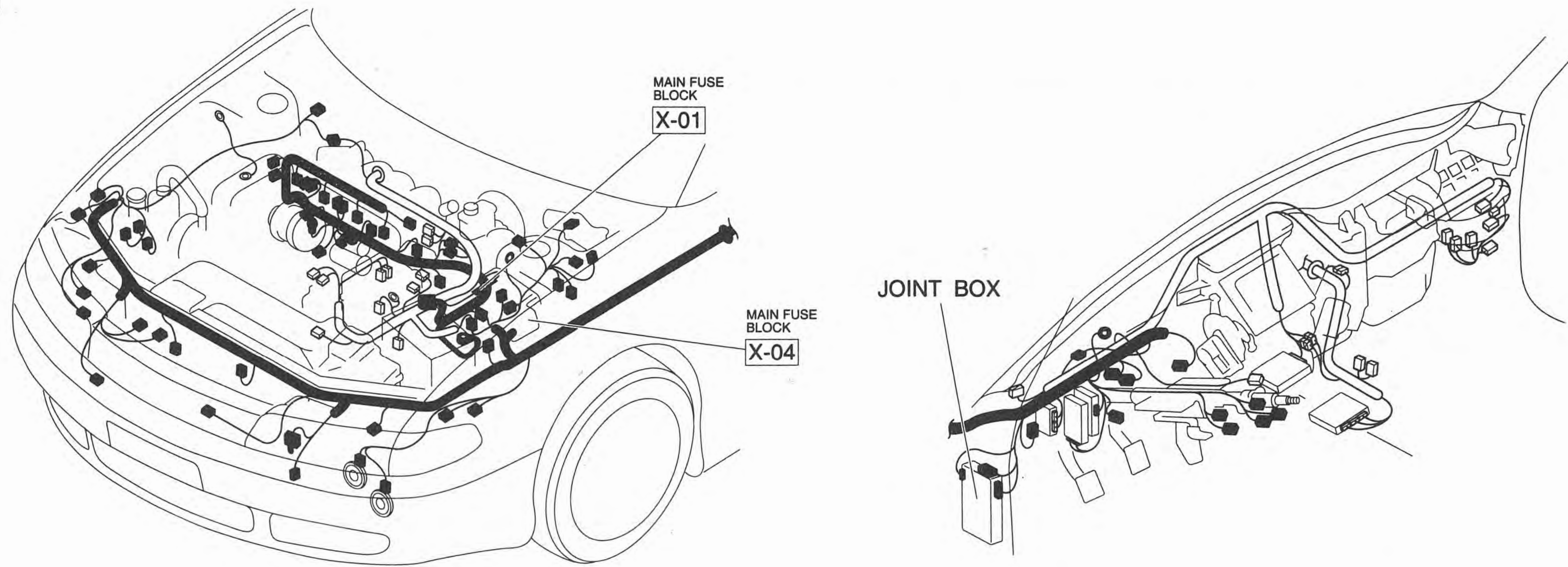

K-6 MX-6 ■ POWER DOOR LOCKS (WITH KEYLESS ENTRY SYSTEM)

THE CPU CONSIST OF T-a, T-b, K-6
▲...WITH THEFT-DETERRENT SYSTEM

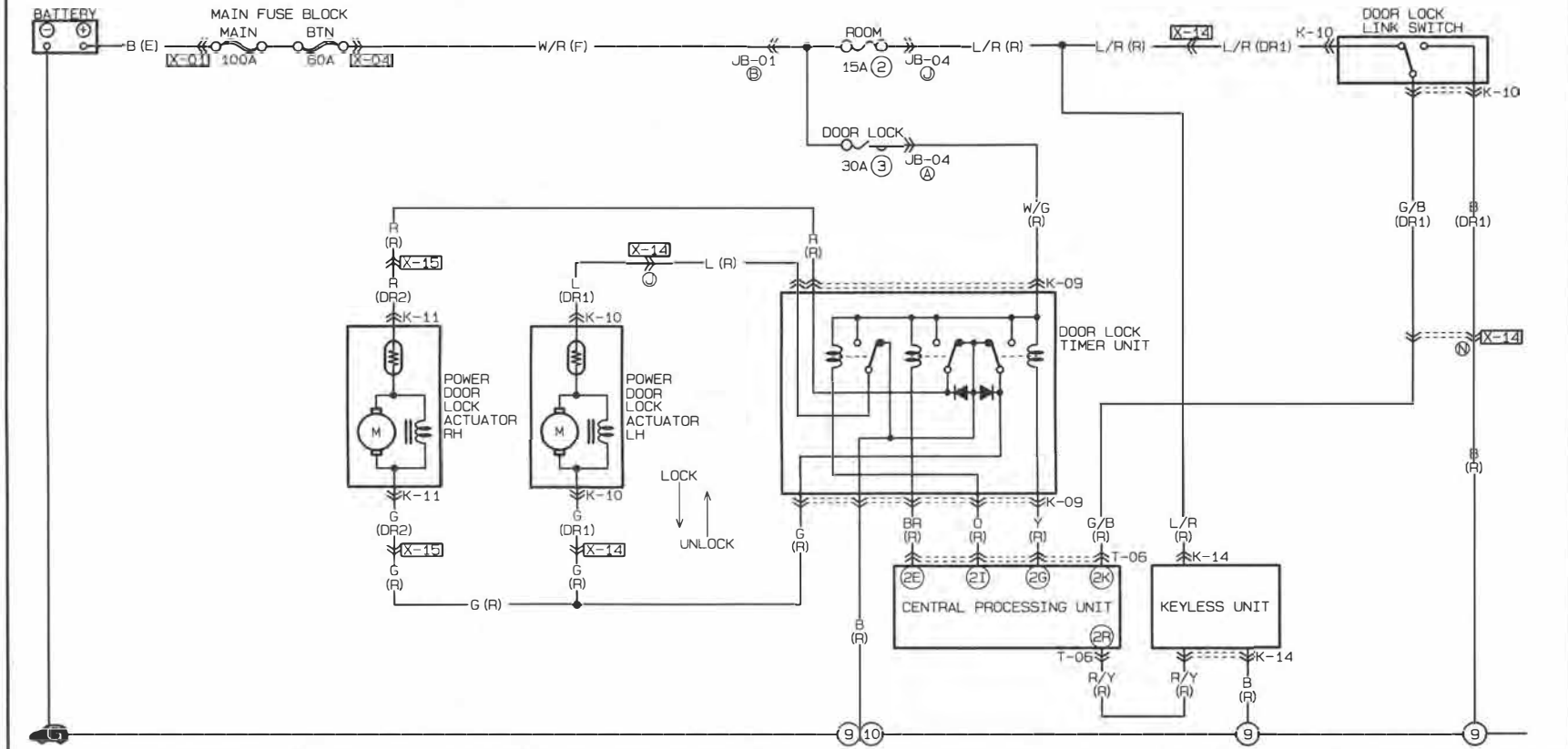

K-09 DOOR LOCK TIMER UNIT (R)

W/G	BR		G
B	Y	R	L

K-10 POWER DOOR LOCK ACTUATOR LH AND DOOR LOCK LINK SWITCH (DR1)



K-11 POWER DOOR LOCK ACTUATOR RH (DR2)



K-14 KEYLESS UNIT (R)

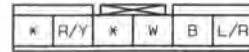

T-06 CENTRAL PROCESSING UNIT (R)

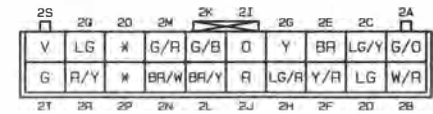

K-6

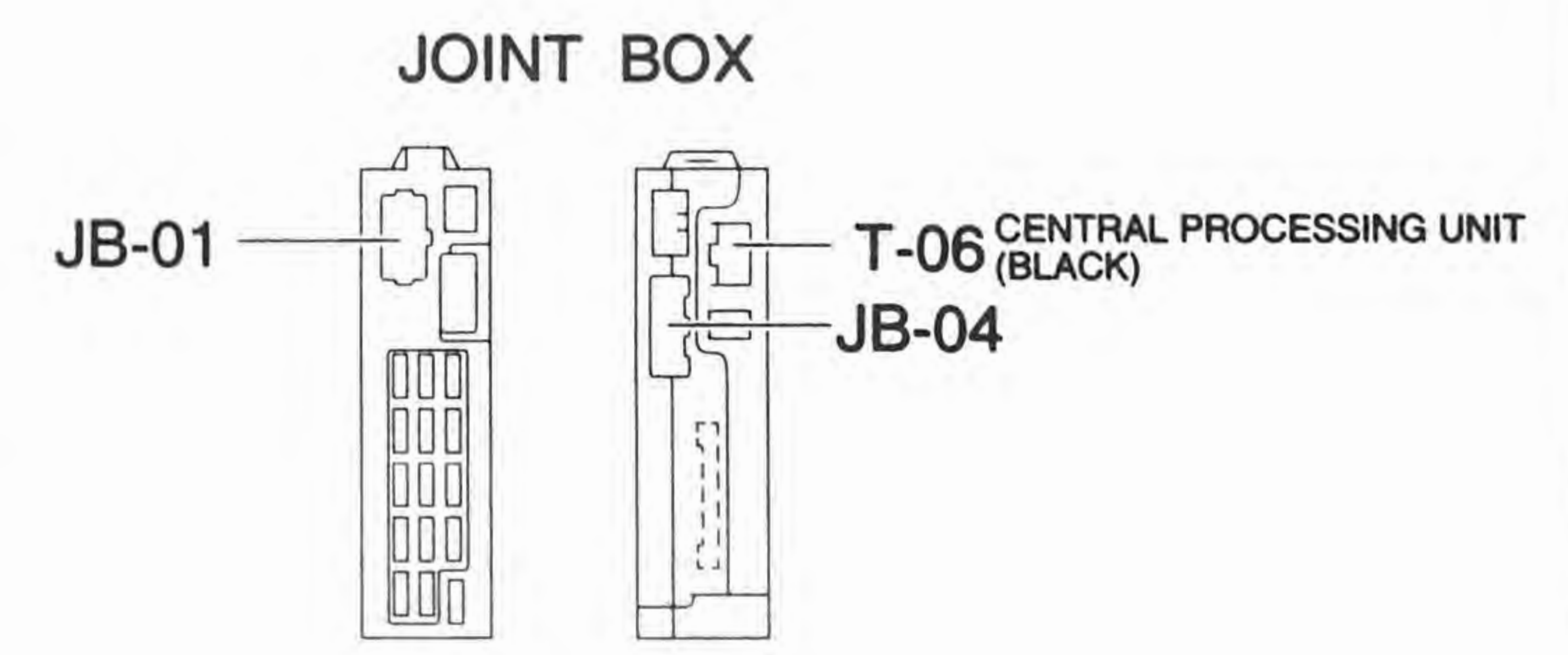
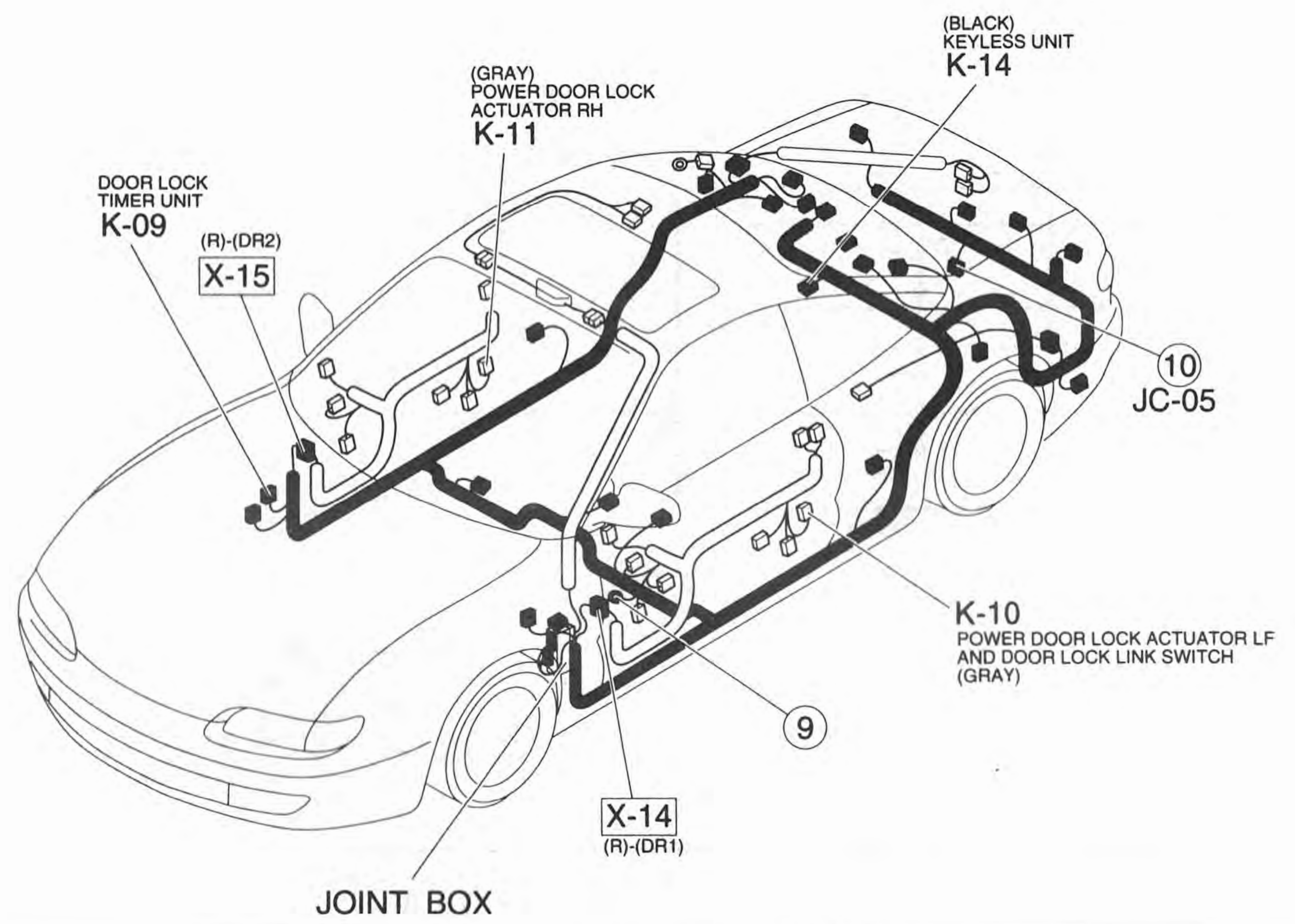
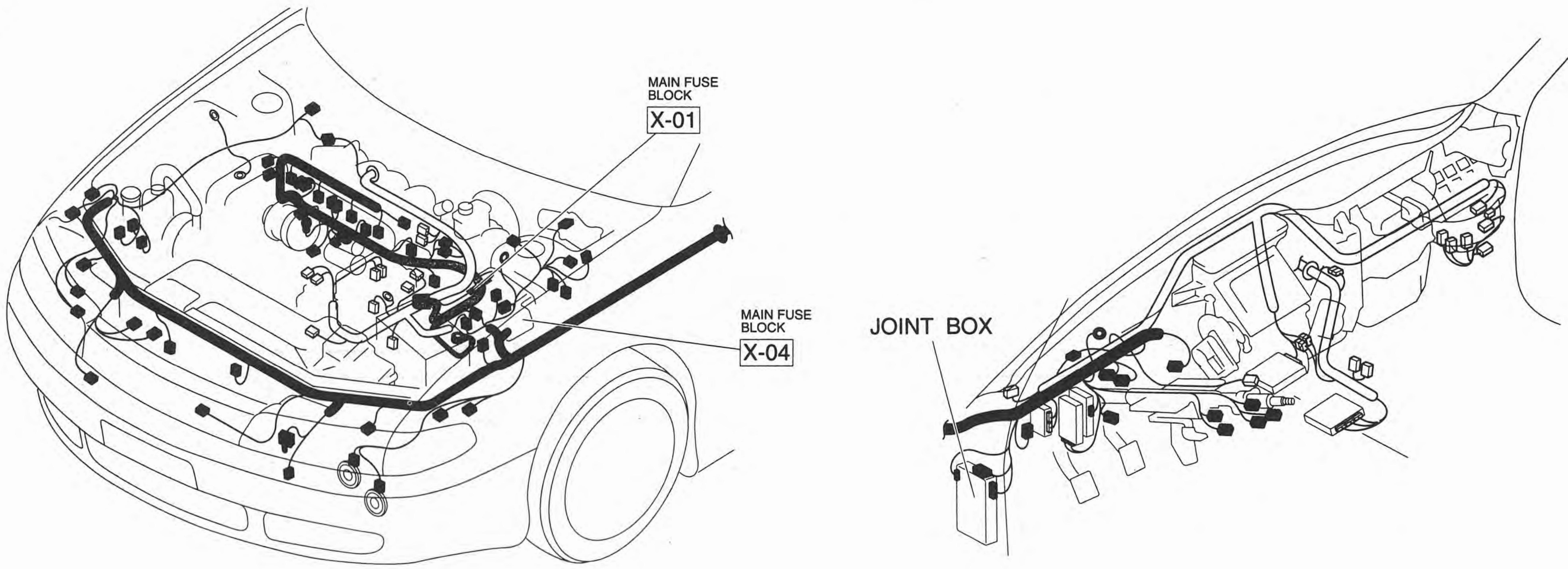

Z WIRING DIAGRAM

L-1 626 ■ POWER OUTSIDE MIRRORS

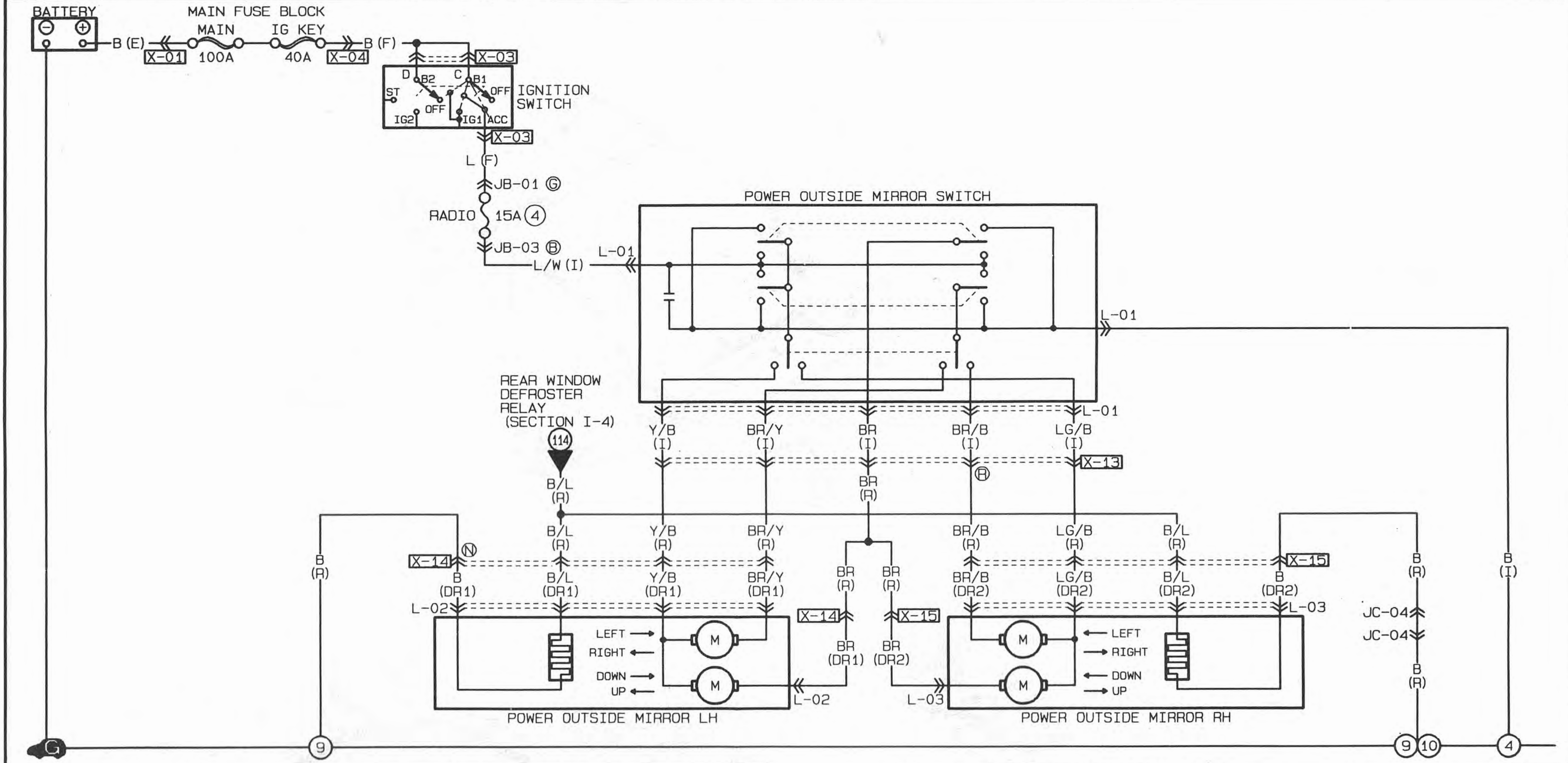

L-01 POWER OUTSIDE MIRROR SWITCH (I)

*	L/W		Y/B	LG/B
BR	B	BR/Y	BR/B	*

L-02 POWER OUTSIDE MIRROR LH (DR1)

BR		B/L
Y/B	BR/Y	*

L-03 POWER OUTSIDE MIRROR RH (DR2)

BR		B/L
LG/B	BR/B	*

L-1

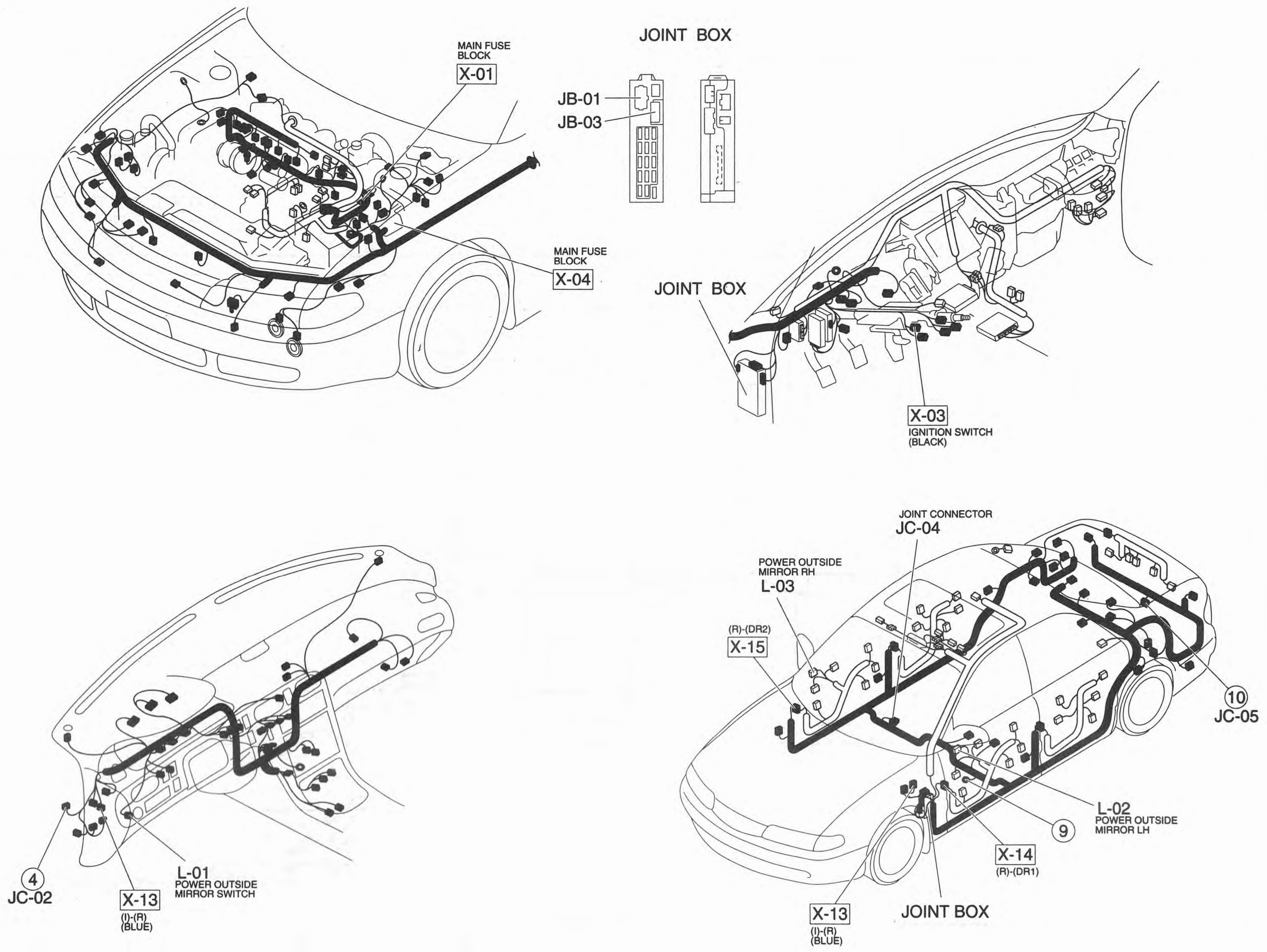

Z WIRING DIAGRAM

L-2 MX-6 ■ POWER OUTSIDE MIRRORS

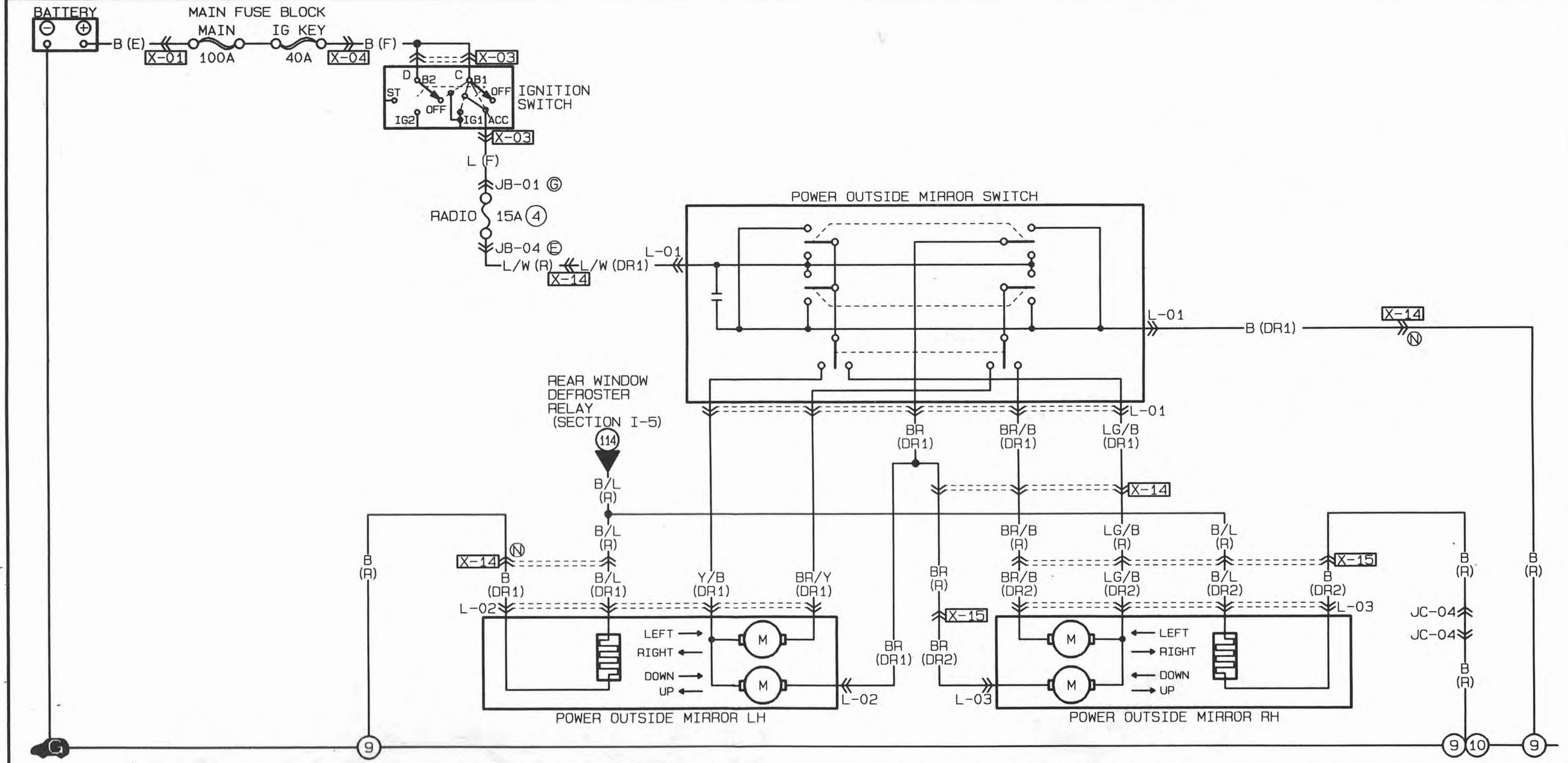

L-01 POWER OUTSIDE MIRROR SWITCH (DR1)

BR	L/W		LG/B	Y/B
B	*	*	BR/Y	BR/B

L-02 POWER OUTSIDE MIRROR LH (DR1)

BR	Y/B	BR/Y	*	B/L	B
----	-----	------	---	-----	---

L-03 POWER OUTSIDE MIRROR RH (DR2)

BR	LG/B	BR/B	*	B/L	B
----	------	------	---	-----	---

L-2

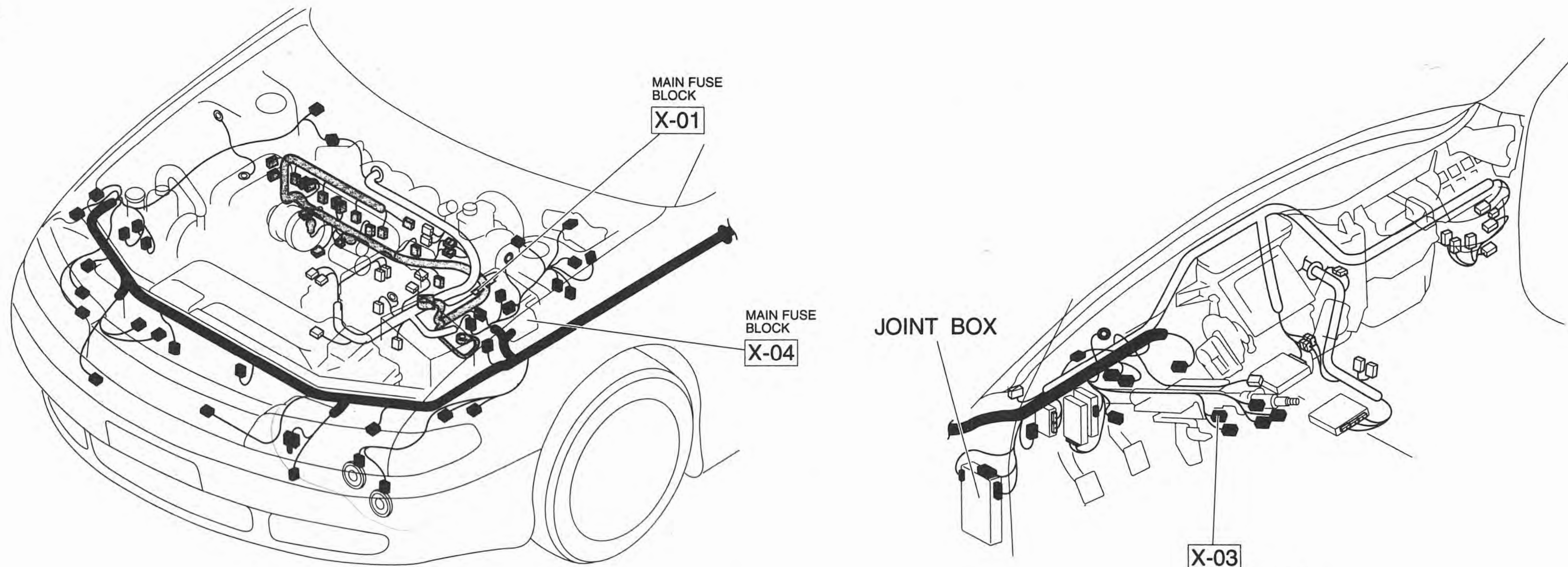

JOINT BOX

X-03
IGNITION SWITCH
(BLACK)

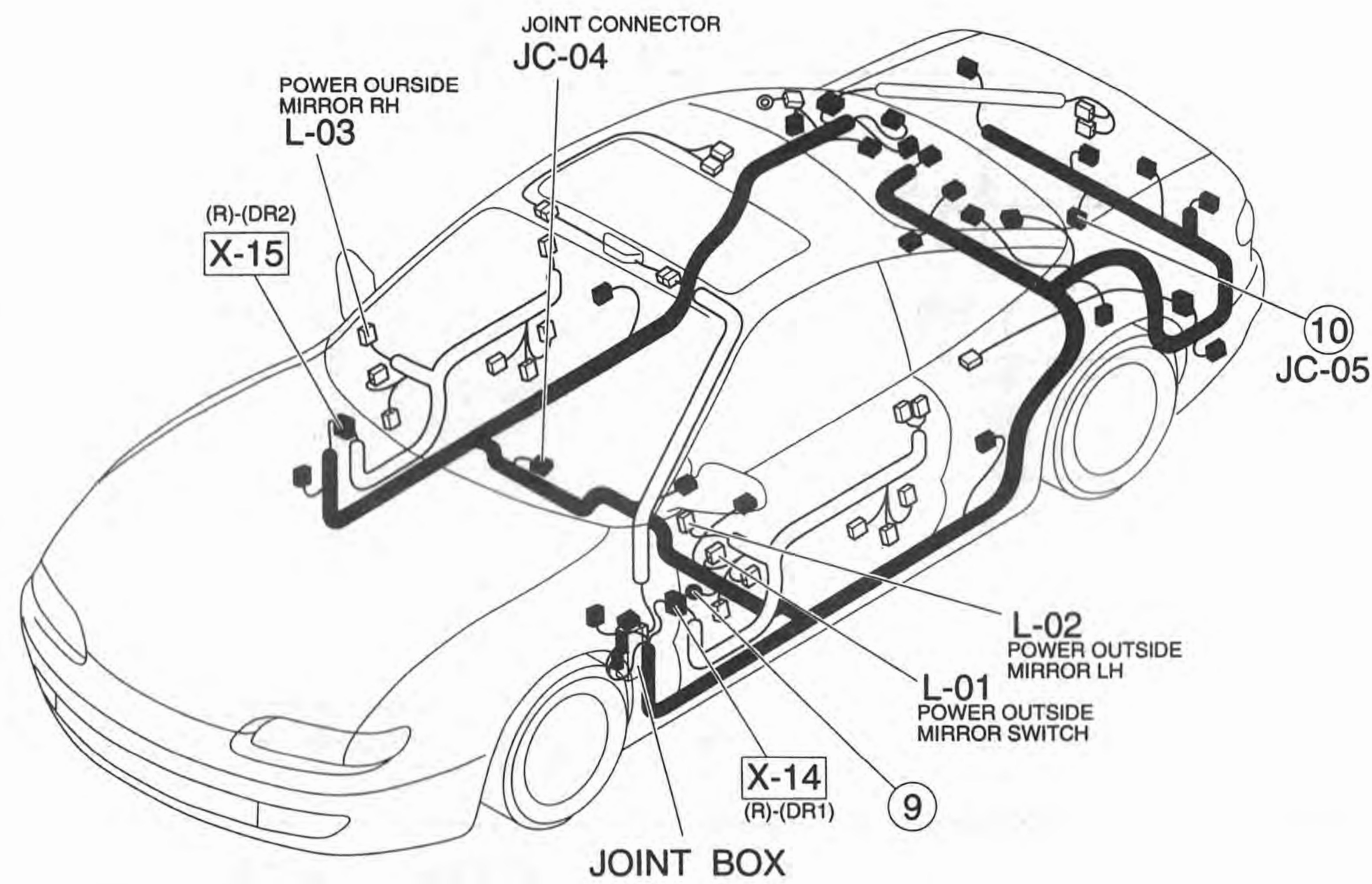

JOINT BOX

JB-01

JB-04

M-1 626 ■ SLIDING SUNROOF

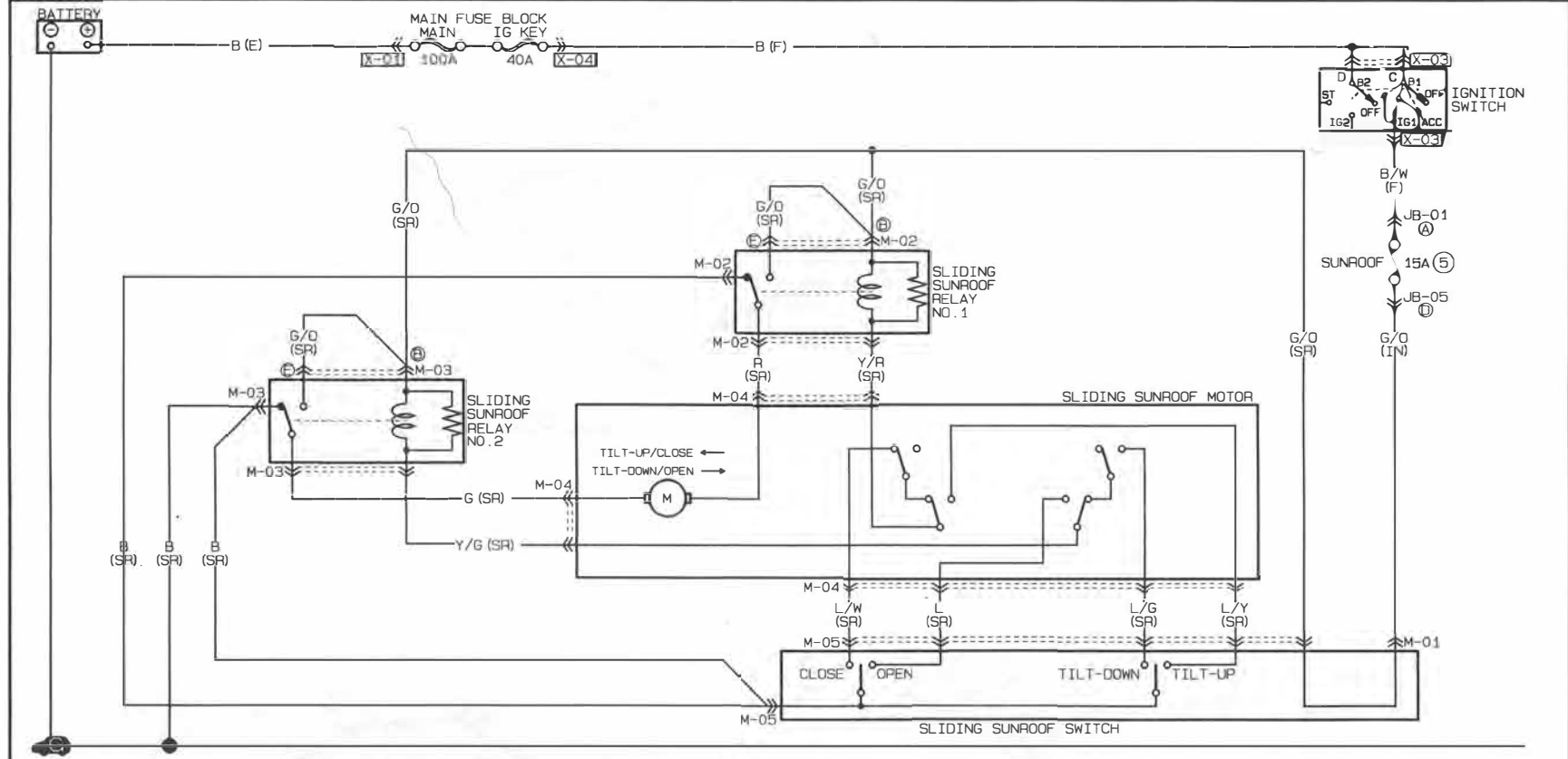

<p>M-01 SLIDING SUNROOF SWITCH (IN)</p>	<p>M-02 SLIDING SUNROOF RELAY NO. 1 (SR)</p>	<p>M-03 SLIDING SUNROOF RELAY NO. 2 (SR)</p>	<p>M-04 SLIDING SUNROOF MOTOR (SR)</p>	<p>M-05 SLIDING SUNROOF SWITCH (SR)</p>		

M-1

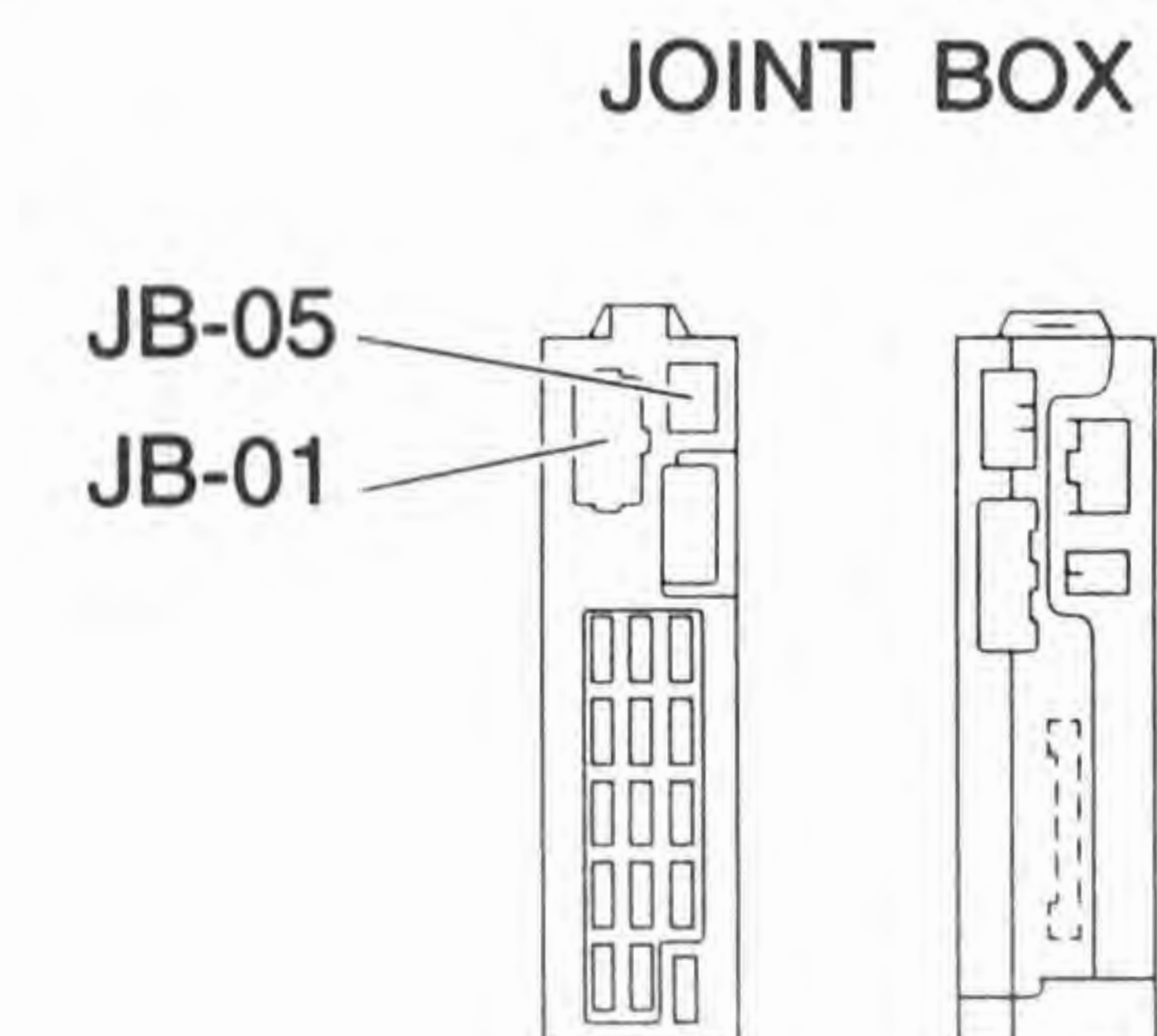
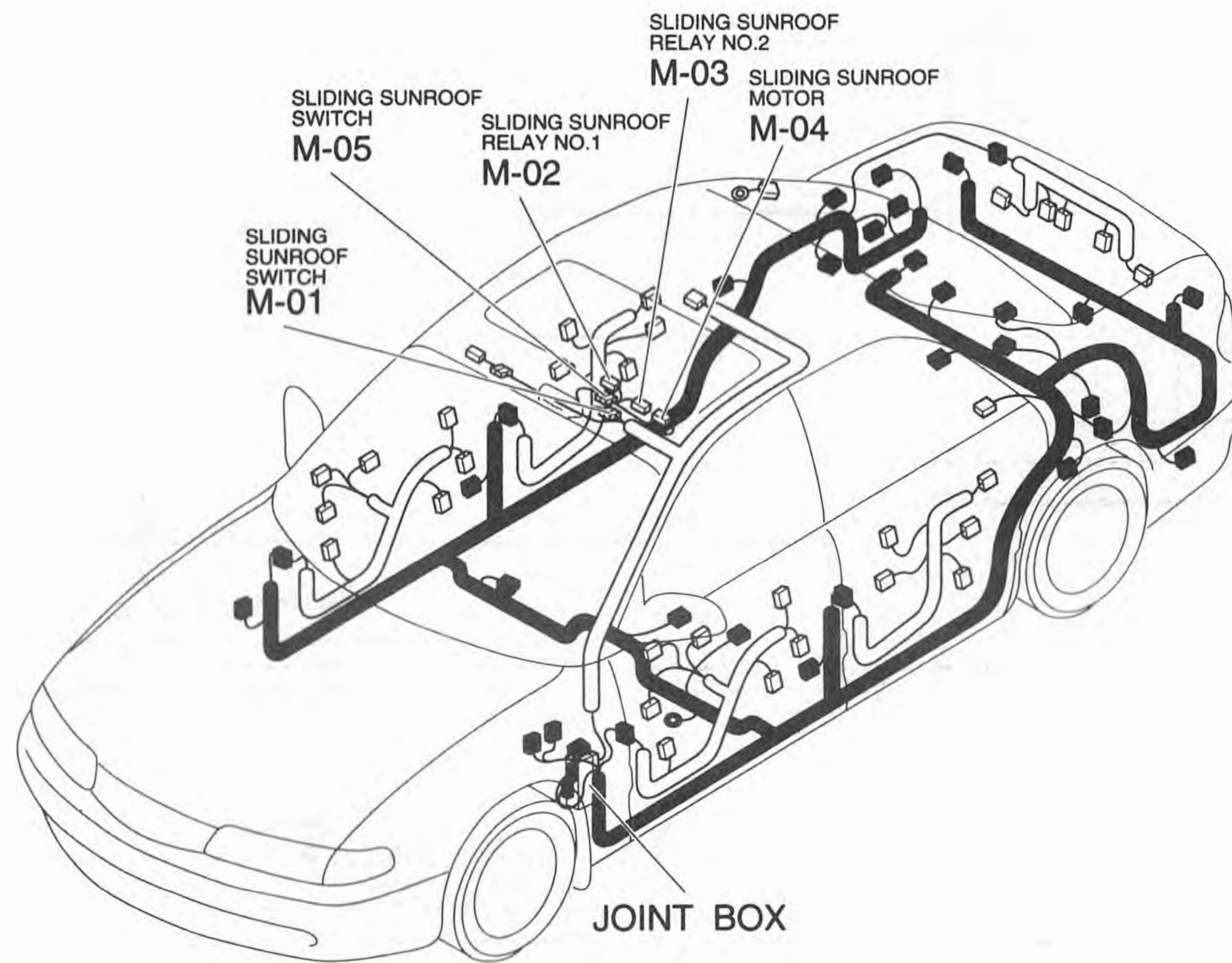
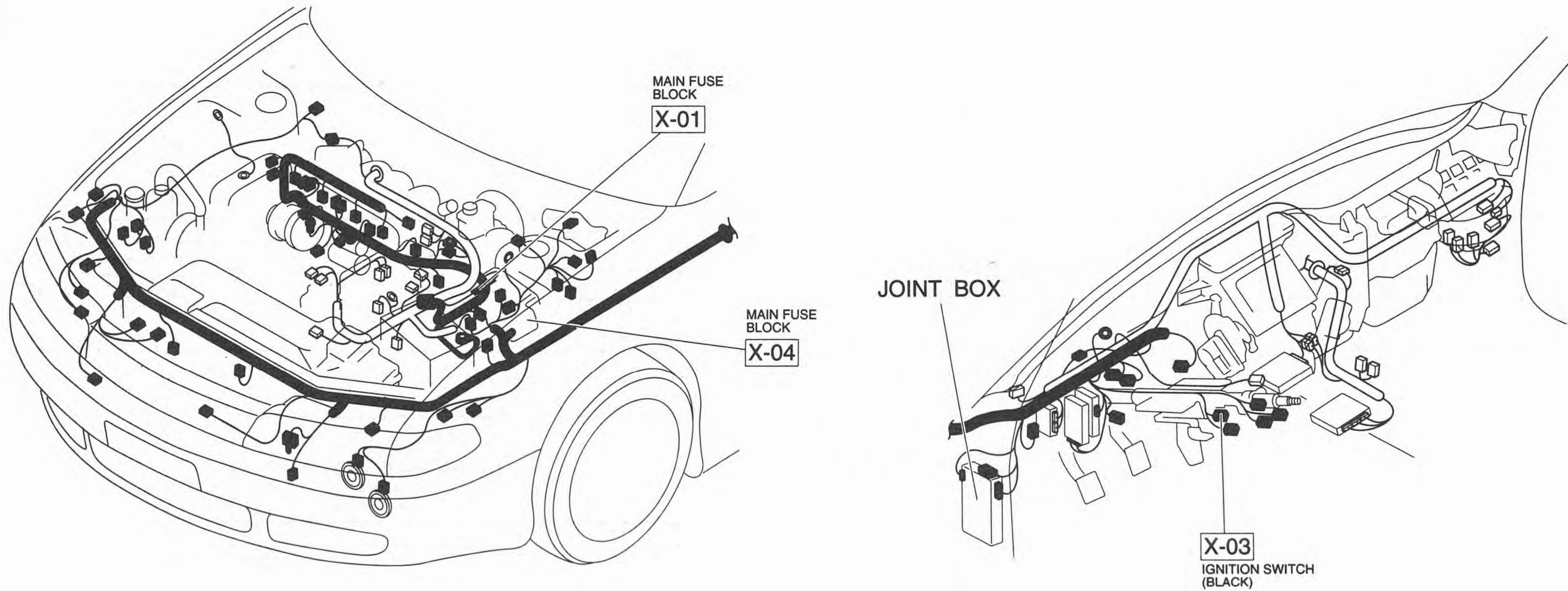

Z WIRING DIAGRAM

M-2 MX-6 ■ SLIDING SUNROOF

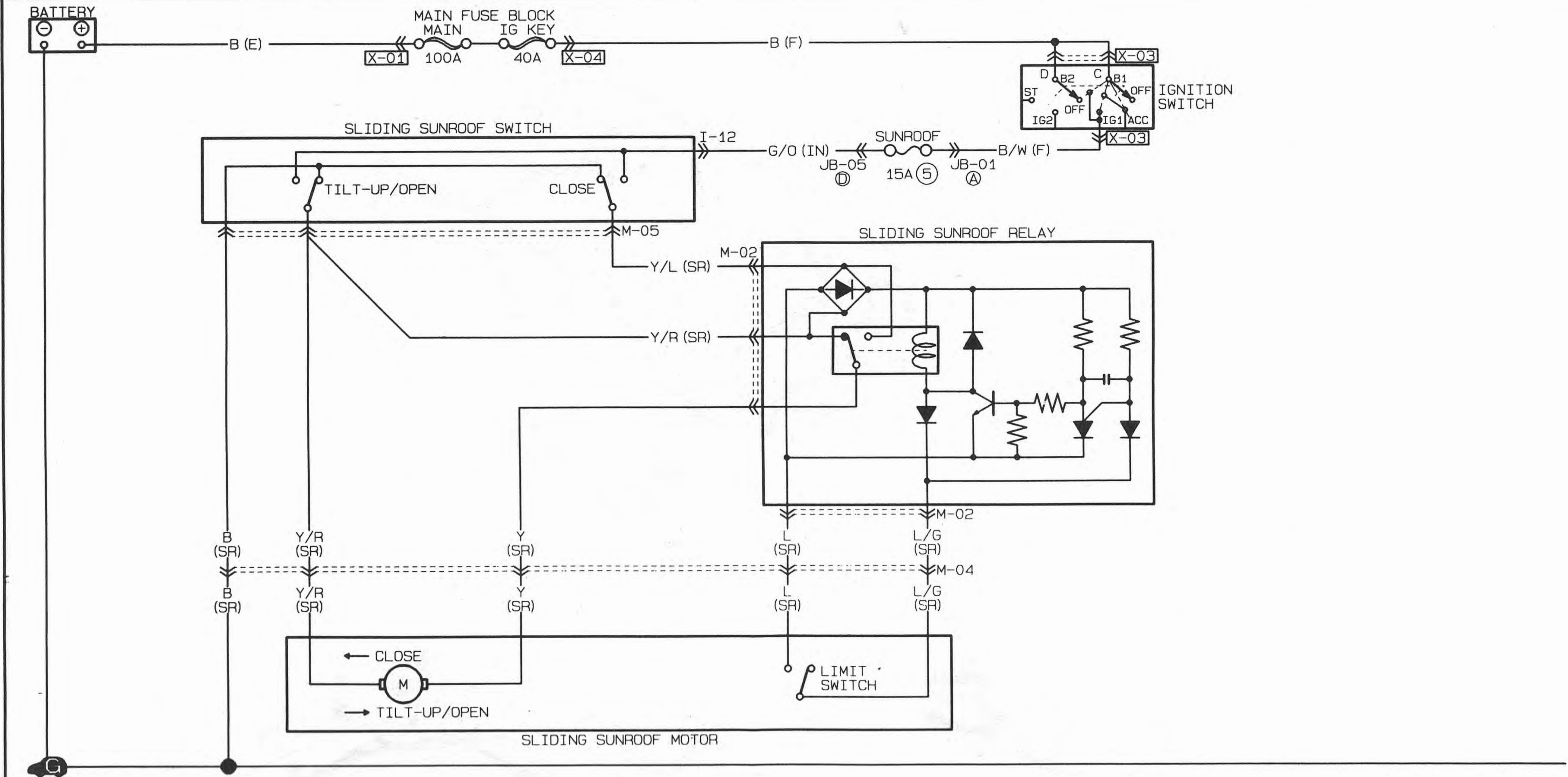

M-02 SLIDING SUNROOF RELAY (SR)

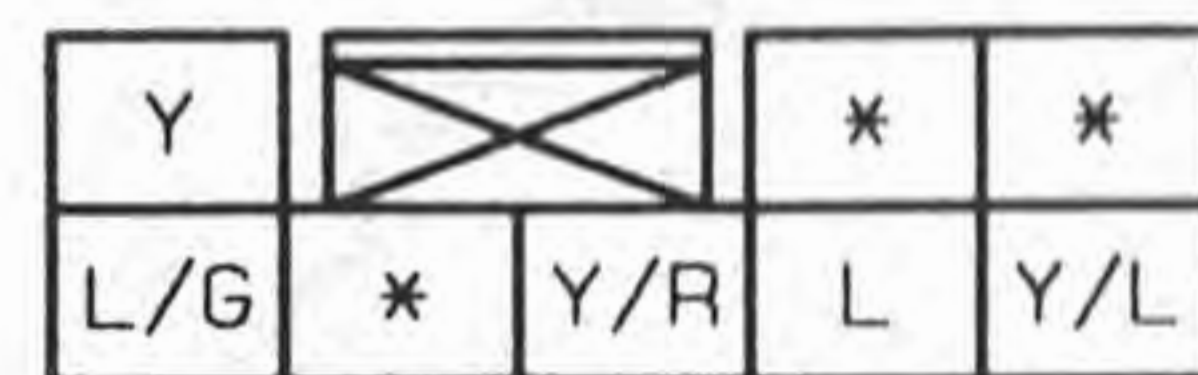

M-04 SLIDING SUNROOF MOTOR (SR)
SLIDING SUNROOF SWITCH SIDE

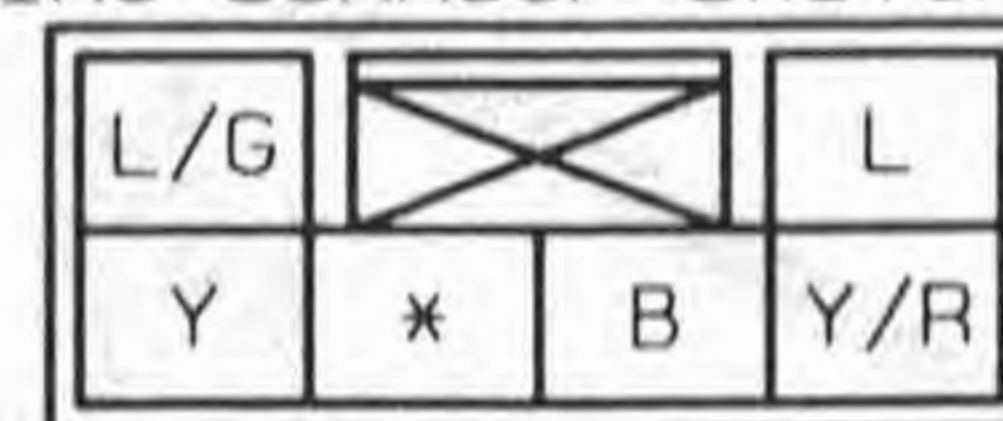

SLIDING SUNROOF MOTOR SIDE



M-05 SLIDING SUNROOF SWITCH (SR)

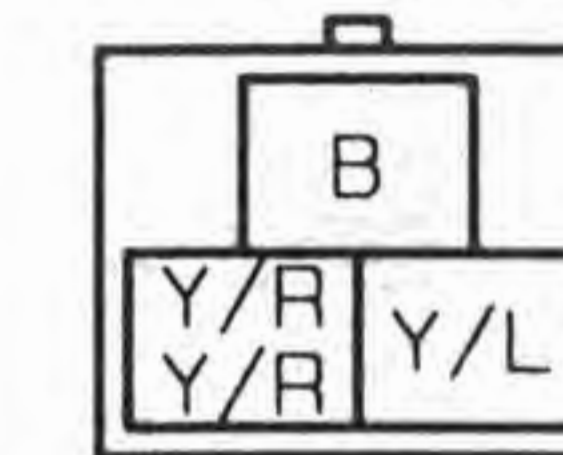

I-12 SLIDING SUNROOF SWITCH (SR)

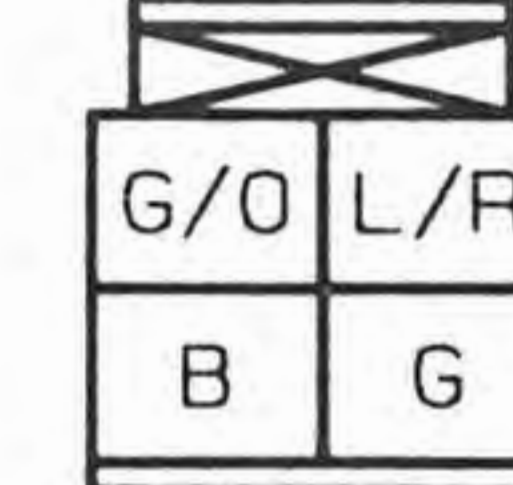

M-2

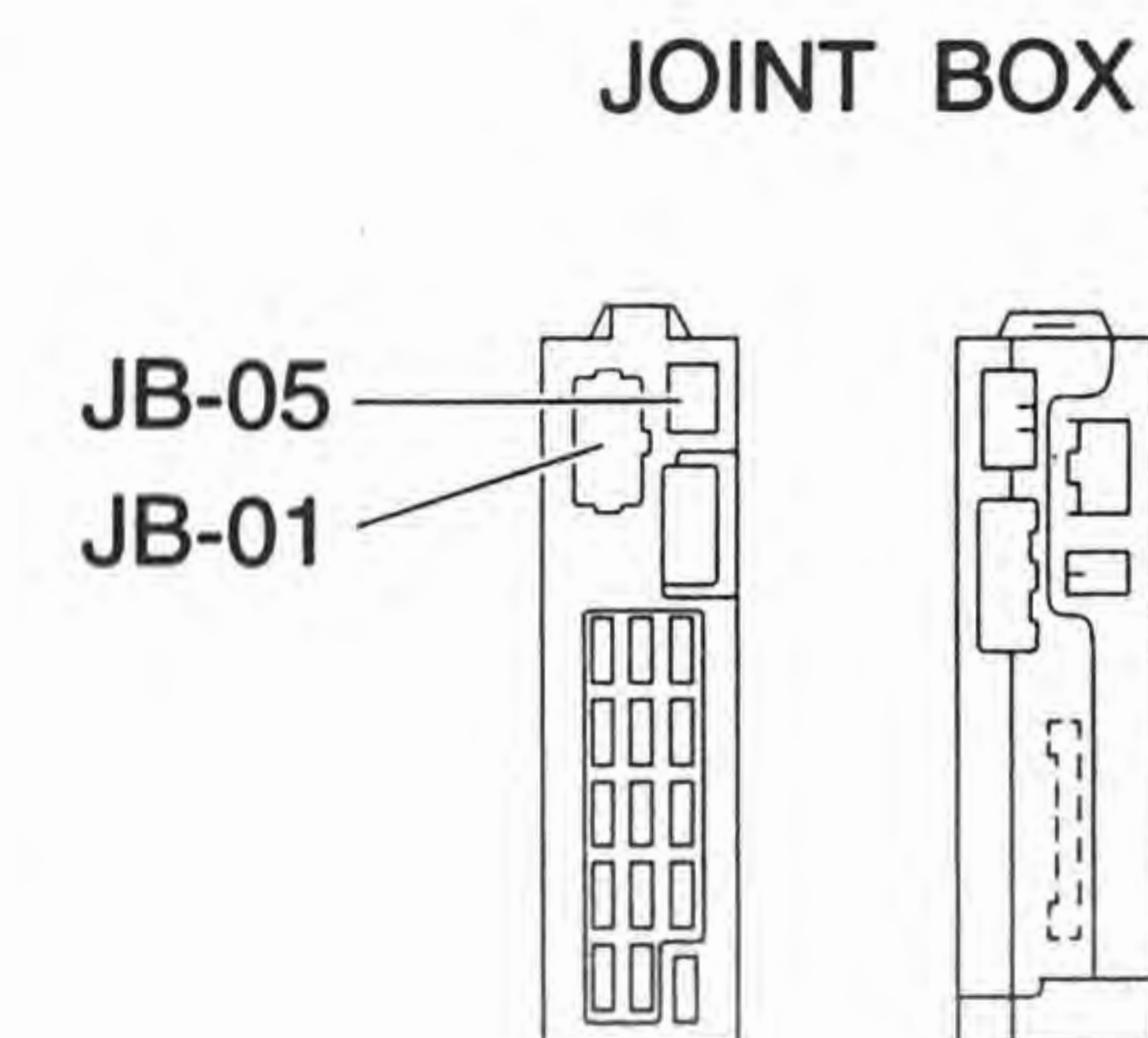
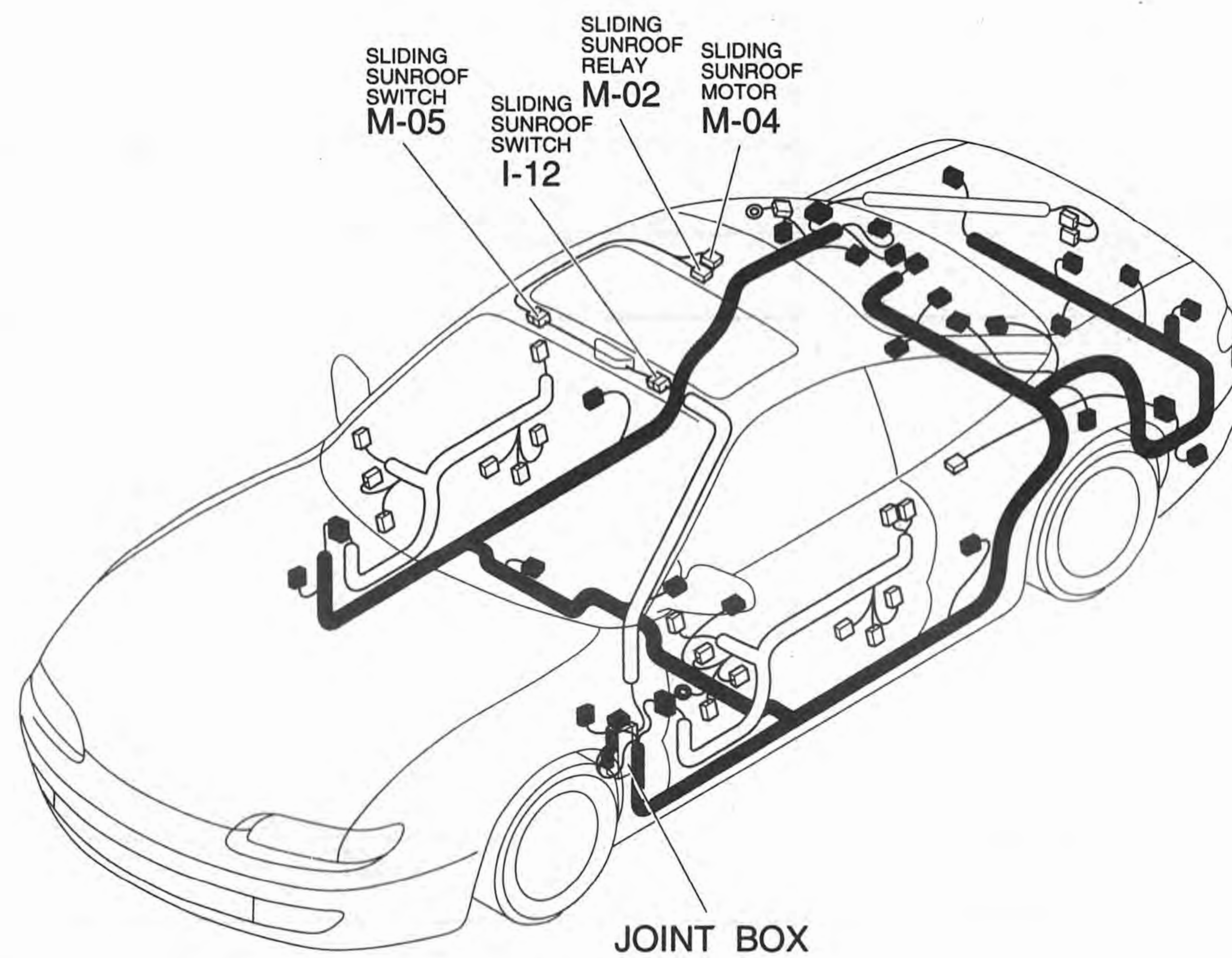
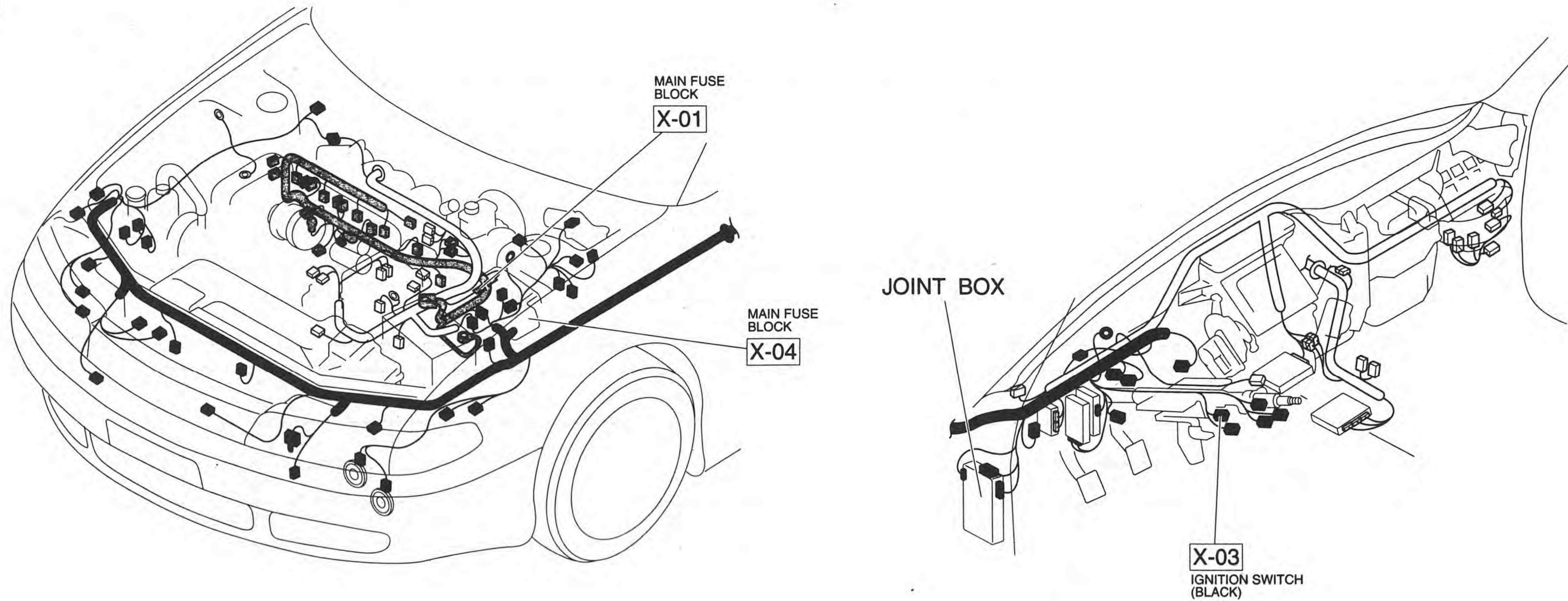

Z WIRING DIAGRAM

0-a ■ ANTILOCK BRAKE SYSTEM (1/2)

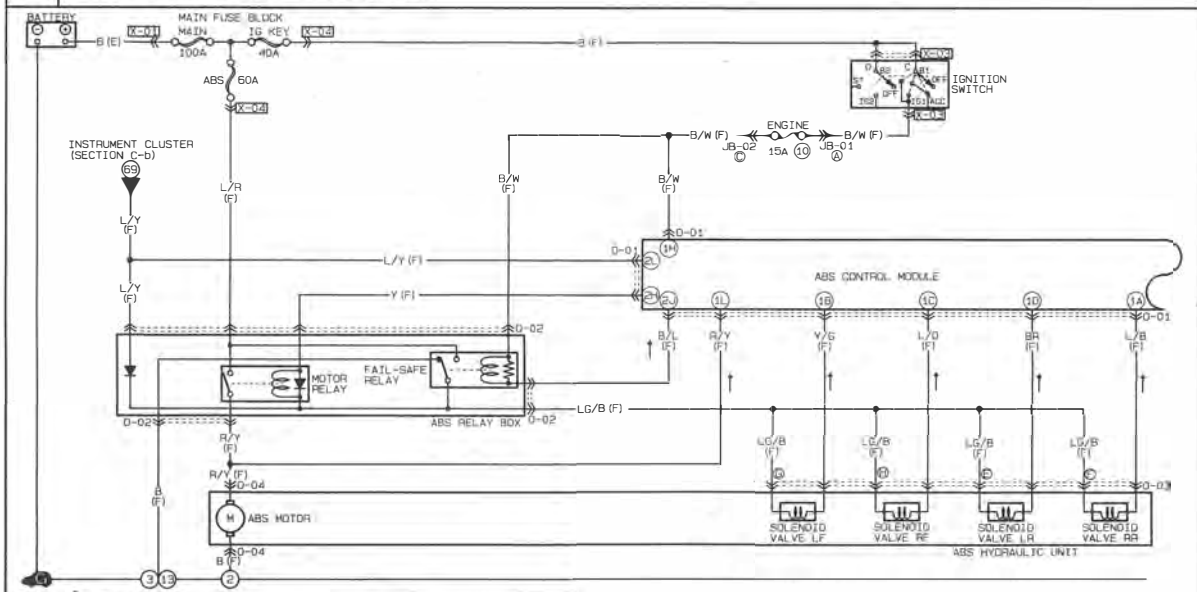

0-01 ABS CONTROL MODULE (F)

1M	1K	1E	1C	1A	2S	2V	2R	2H	2D	2E	2C	2A
W/G	*	*	B	L/O	L/B	BR	V	R	B	*	*	G/B
+	R/Y	*	B/W	B	BR	Y/G						
1H	1I	1J	1N	1P	1O	1B	2L	2J	2I	2F	2O	2B
							L/Y	B/L	Y	*	*	G/B

0-02 ABS RELAY BOX (F)

	R/Y		L/R		
Y	L/Y	L/B	B/W	B/L	B

0-03 ABS HYDRAULIC UNIT (F)

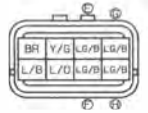

0-04 ABS HYDRAULIC UNIT (F)



O-a

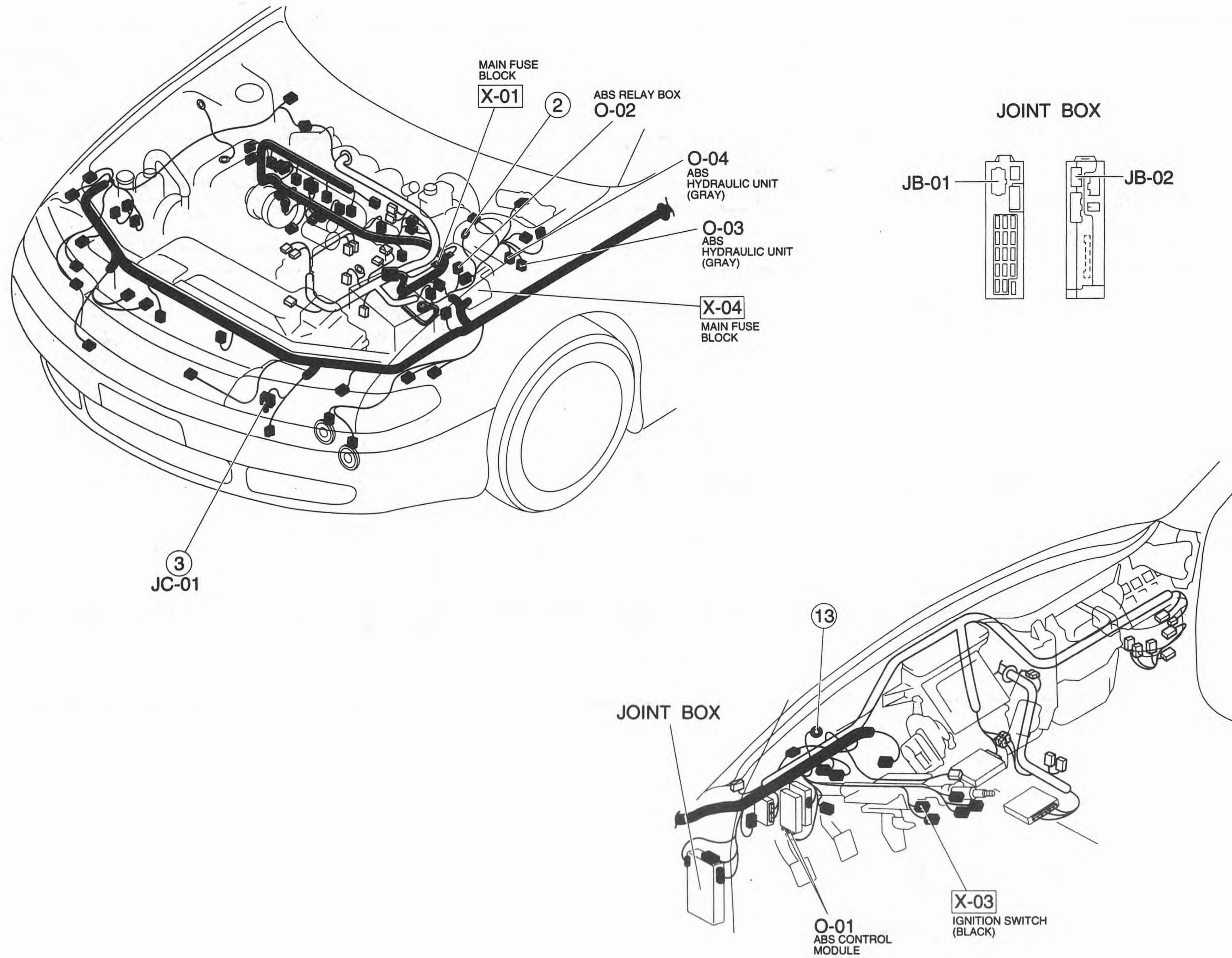

Z WIRING DIAGRAM

O-b ANTILOCK BRAKE SYSTEM (2/2)

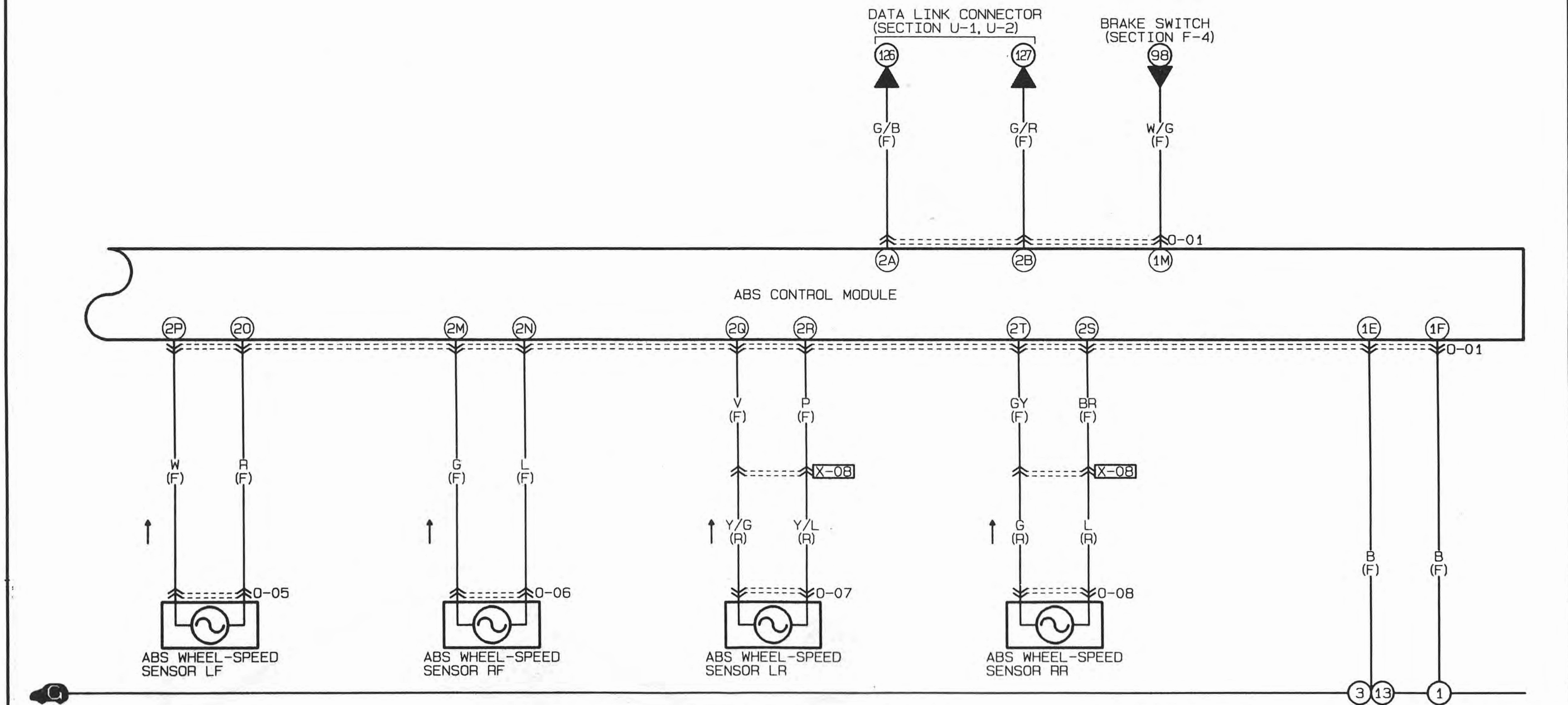

O-01 ABS CONTROL MODULE (F)

1M	1K		1E	1C	1A	2S	2Q	2O	2M		2G	2E	2C	2A		
W/G	*		B	L/O	L/B	BR	V	R	G		*	*	*	G/B		
*	R/Y	*	B/W	B	BR	Y/G	GY	P	W	L	L/Y	B/L	Y	*	*	G/R
1N	1L	1J	1H	1F	1D	1B	2T	2R	2P	2N	2L	2J	2H	2F	2D	2B

O-05 ABS WHEEL-SPEED SENSOR LF (F)

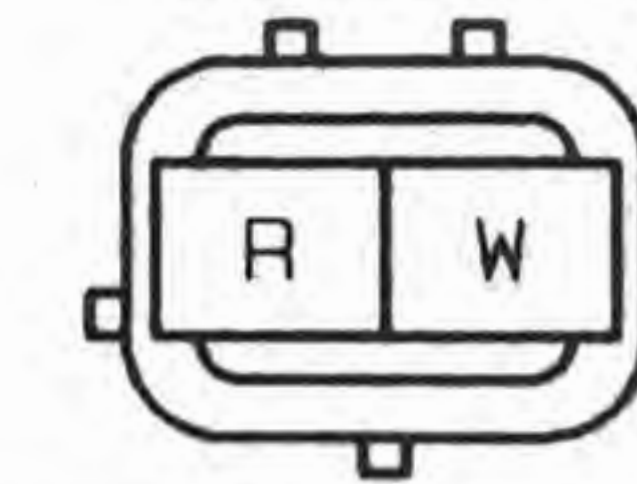

O-06 ABS WHEEL-SPEED SENSOR RF (F)

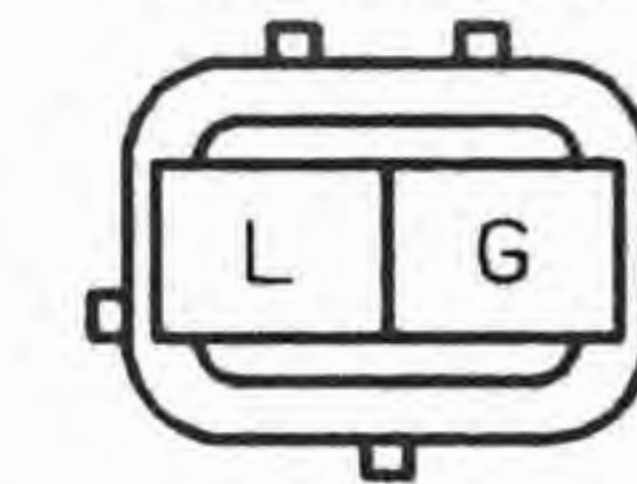

O-07 ABS WHEEL-SPEED SENSOR LR (R)

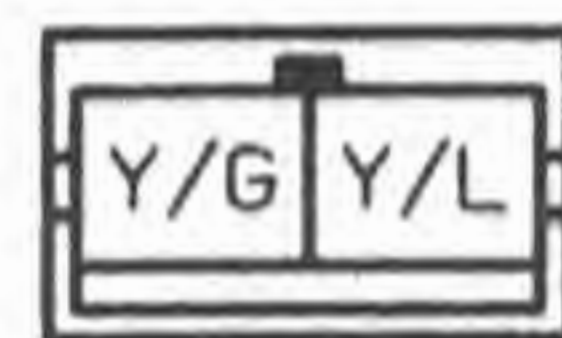

O-08 ABS WHEEL-SPEED SENSOR RR (R)

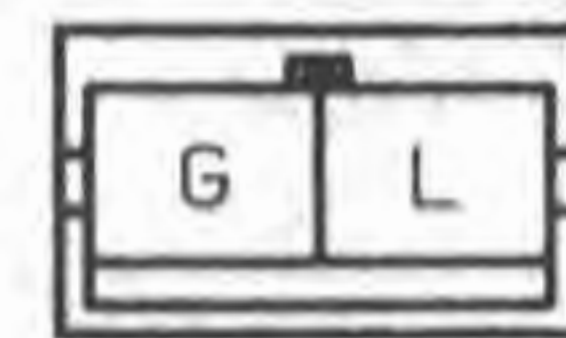

O-b

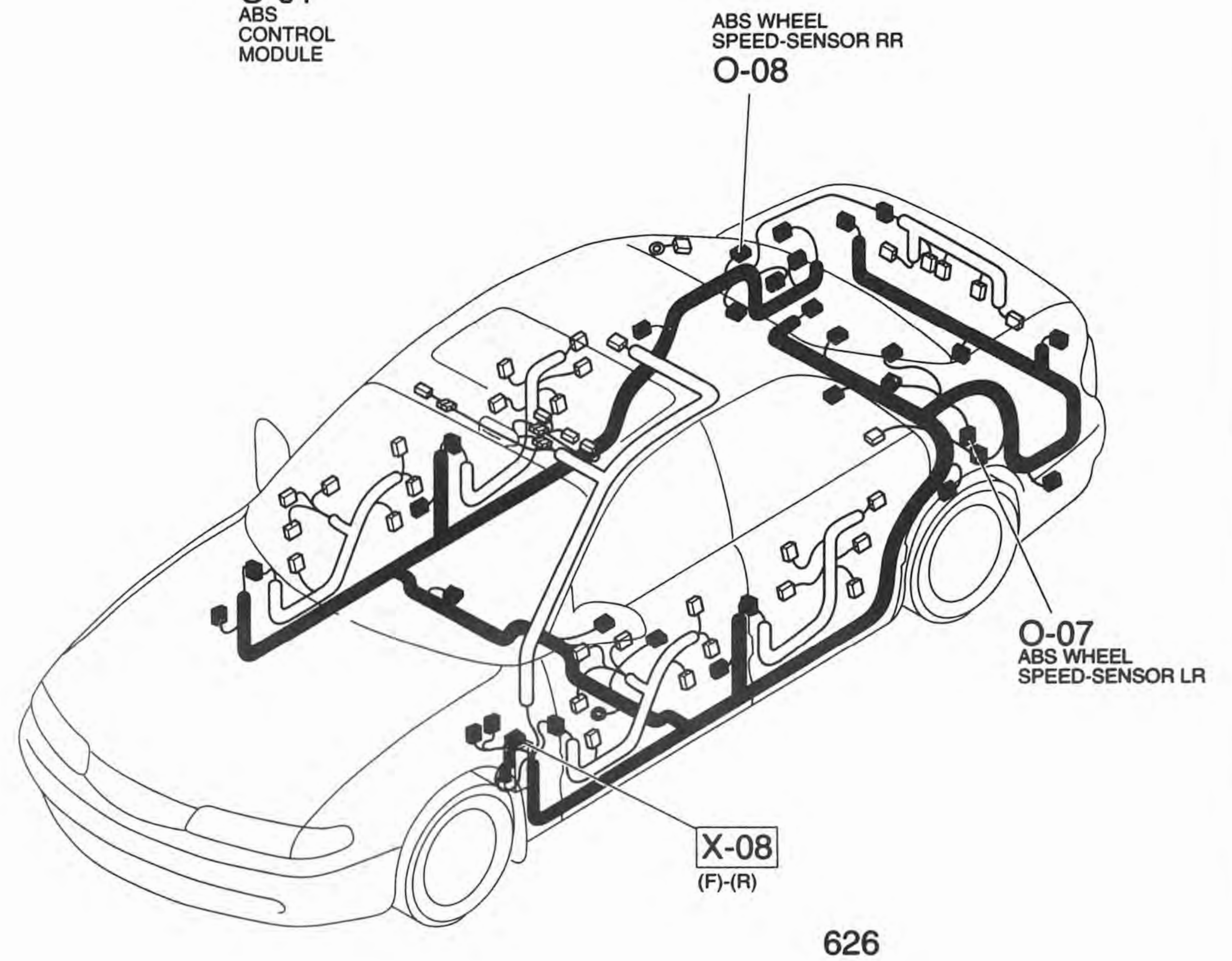
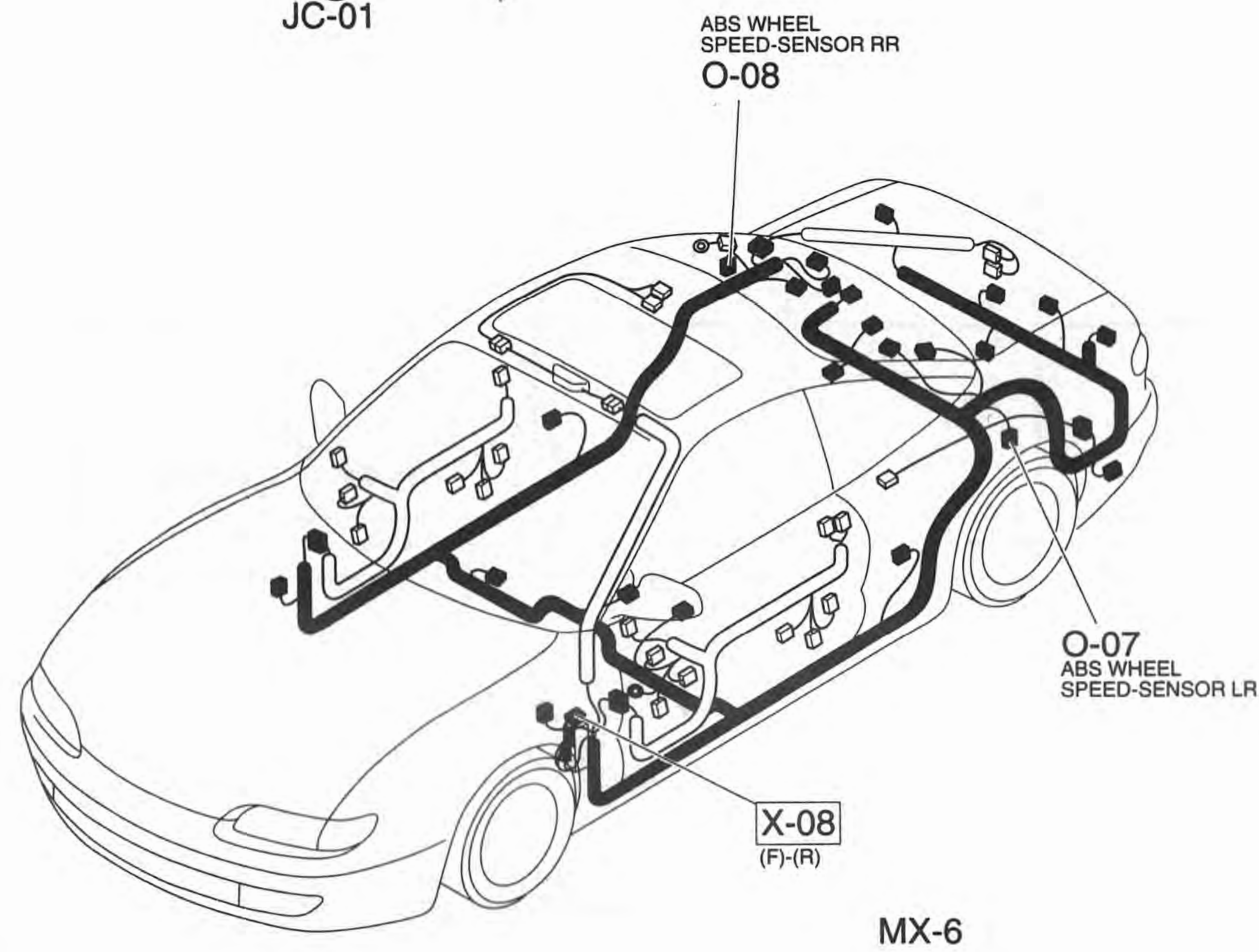
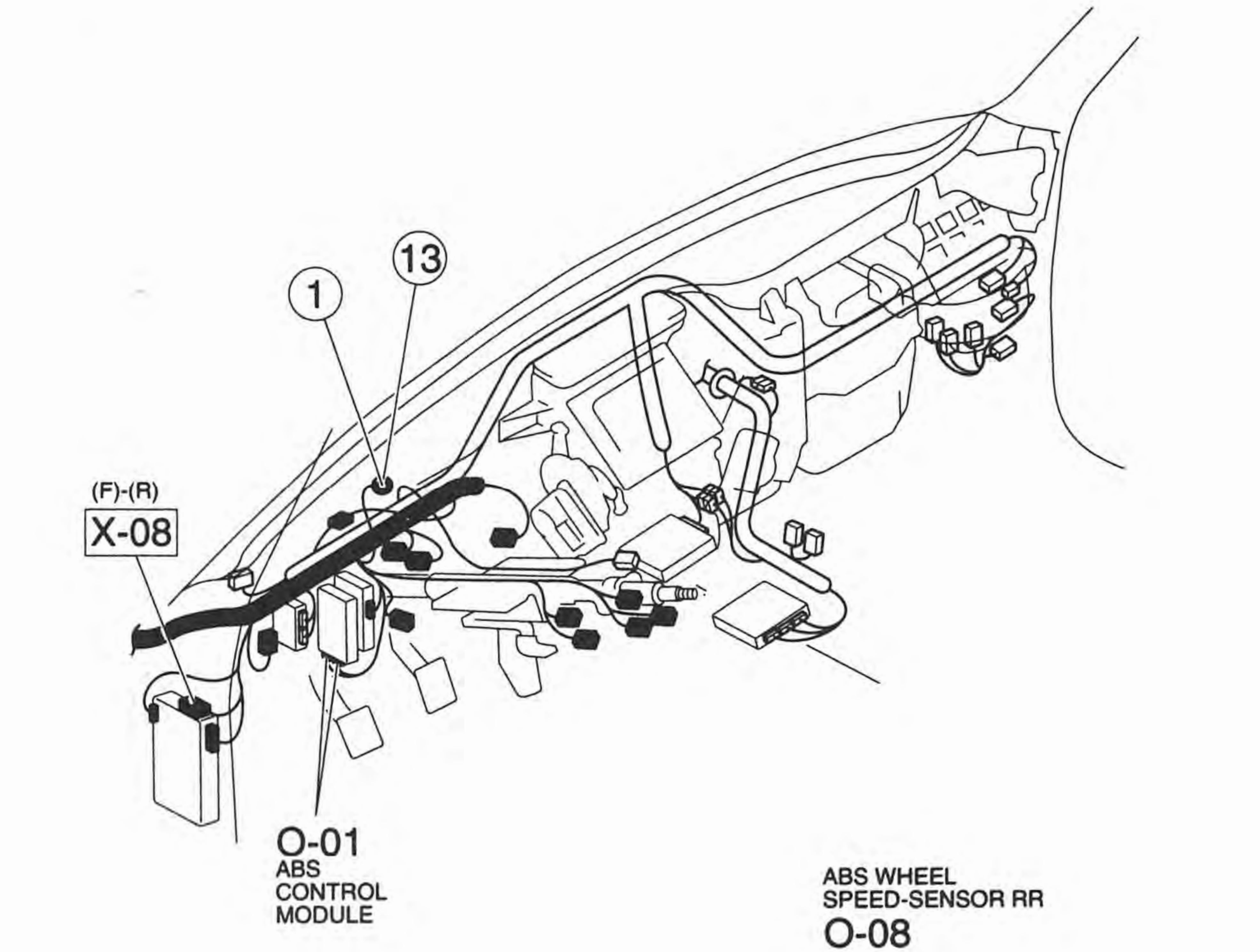
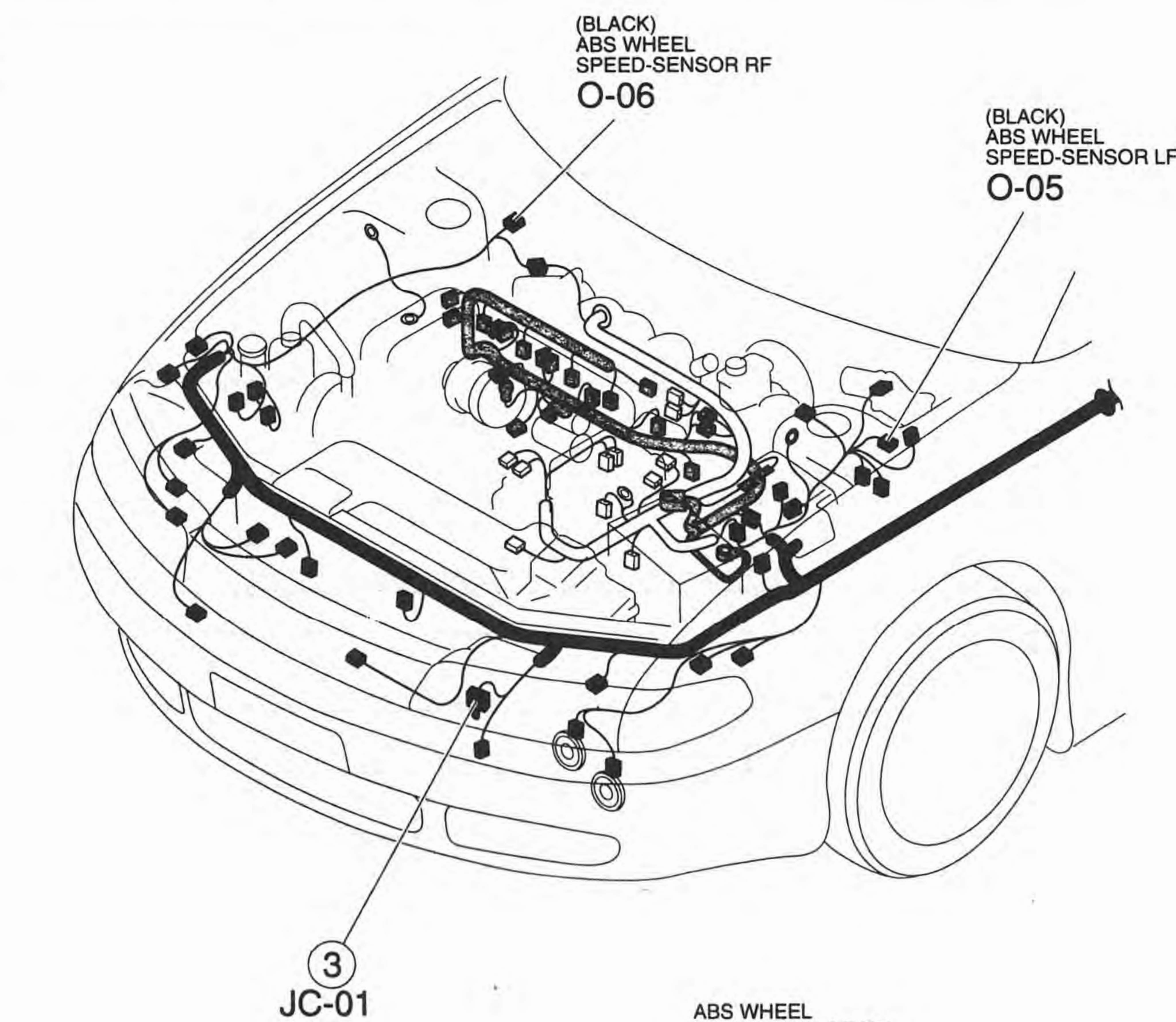

Z WIRING DIAGRAM

P ■ POWER SEAT

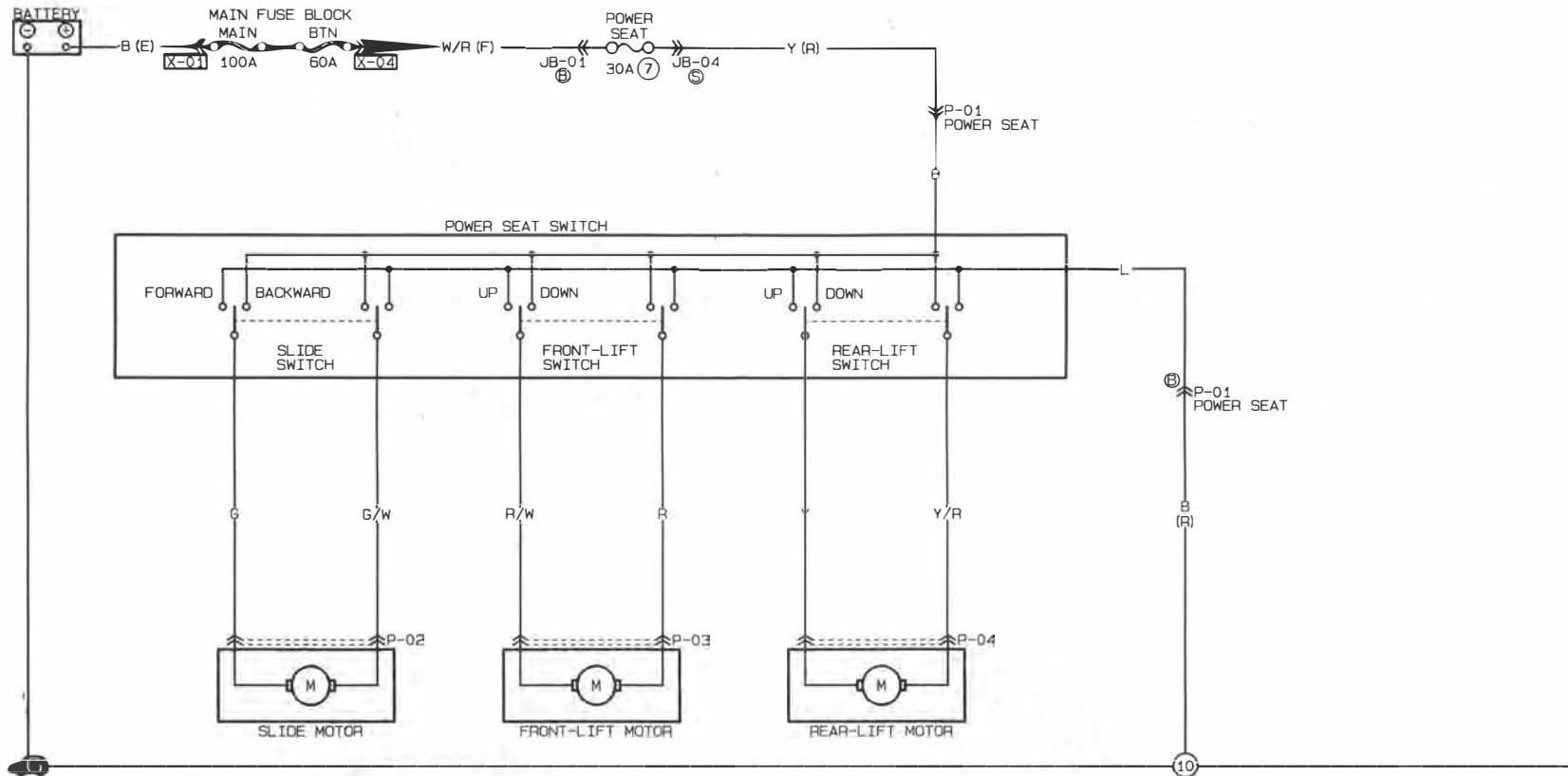

P-01 POWER SEAT (R)	P-02 SLIDE MOTOR	P-03 FRONT-LIFT MOTOR	P-04 REAR-LIFT MOTOR			

P

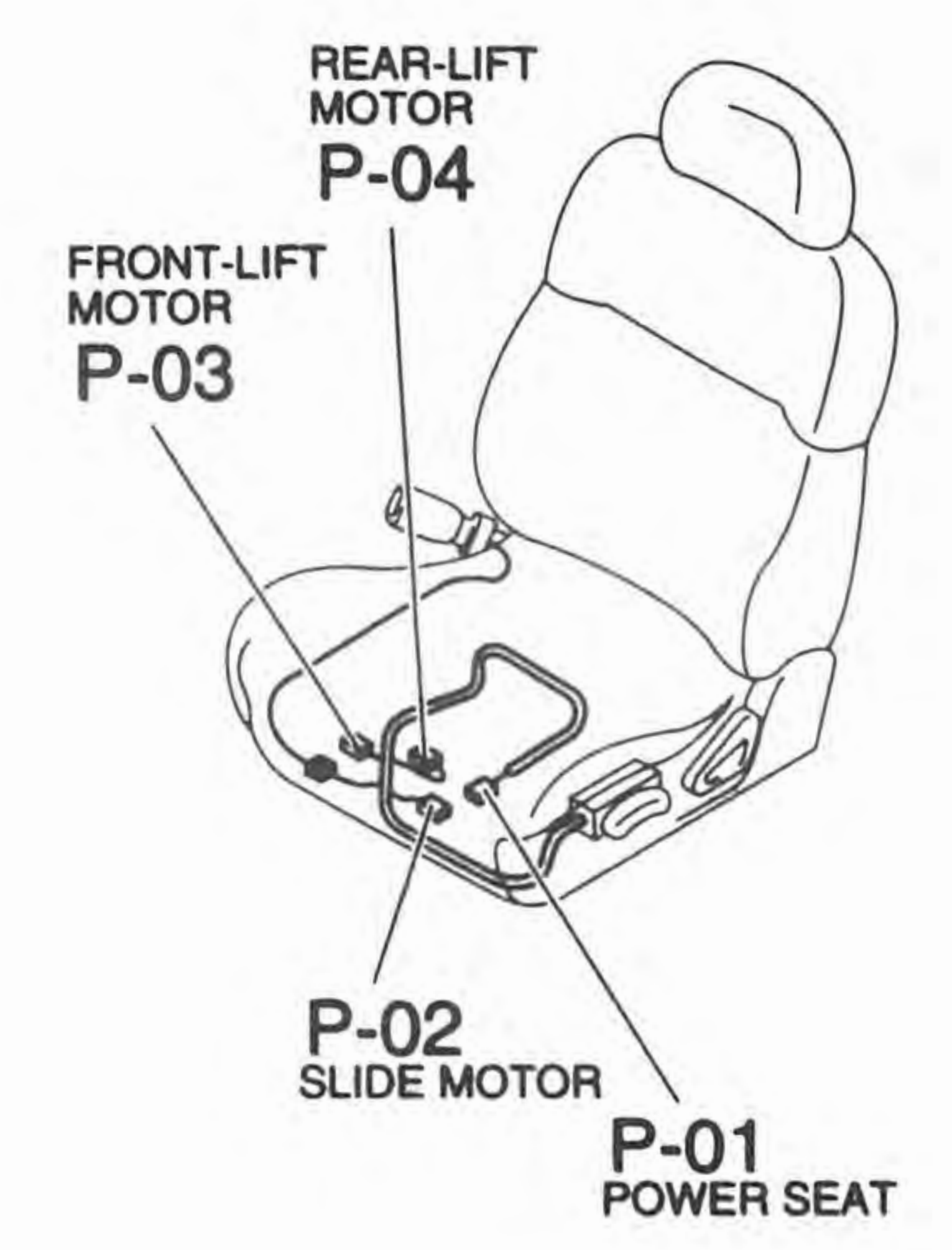
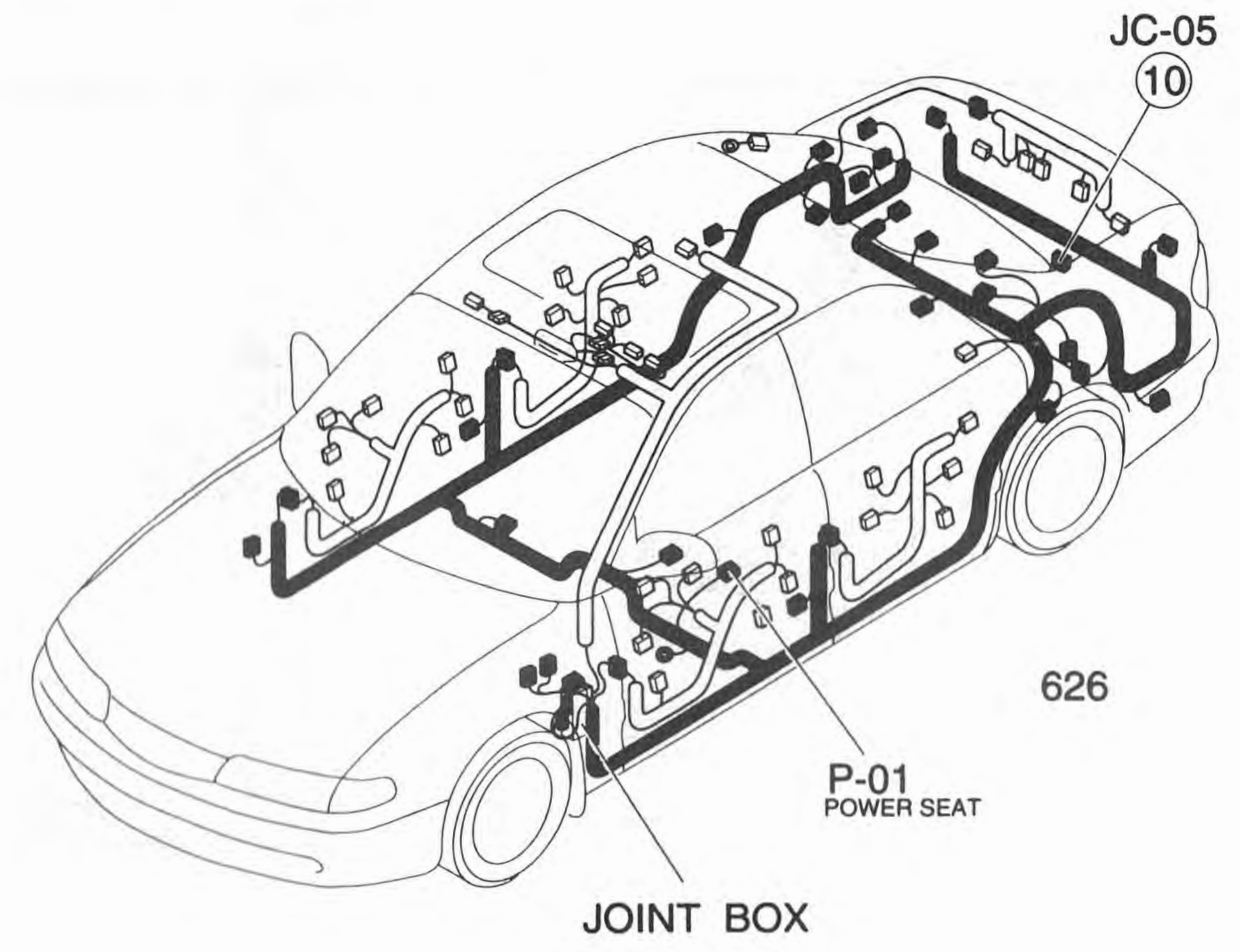
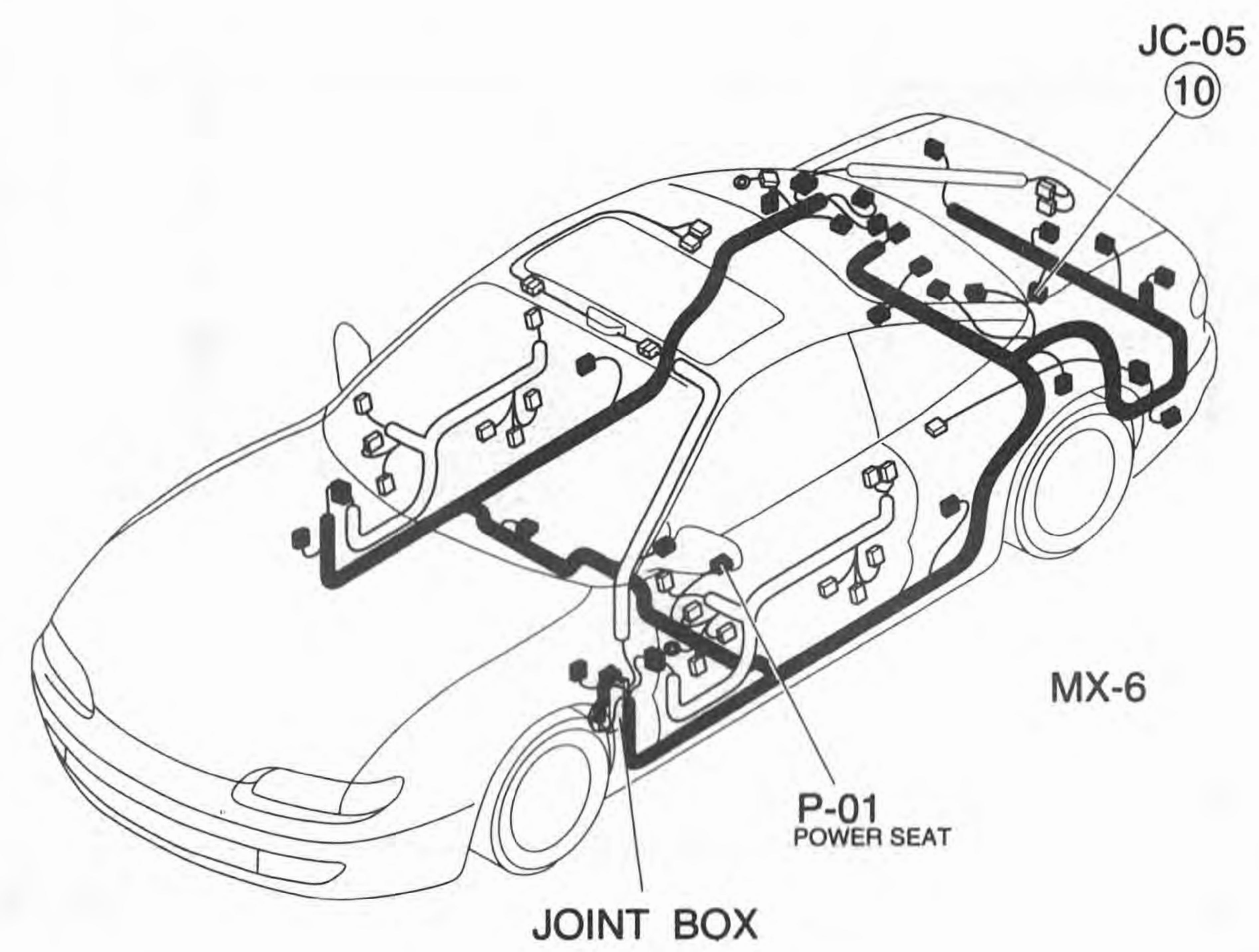
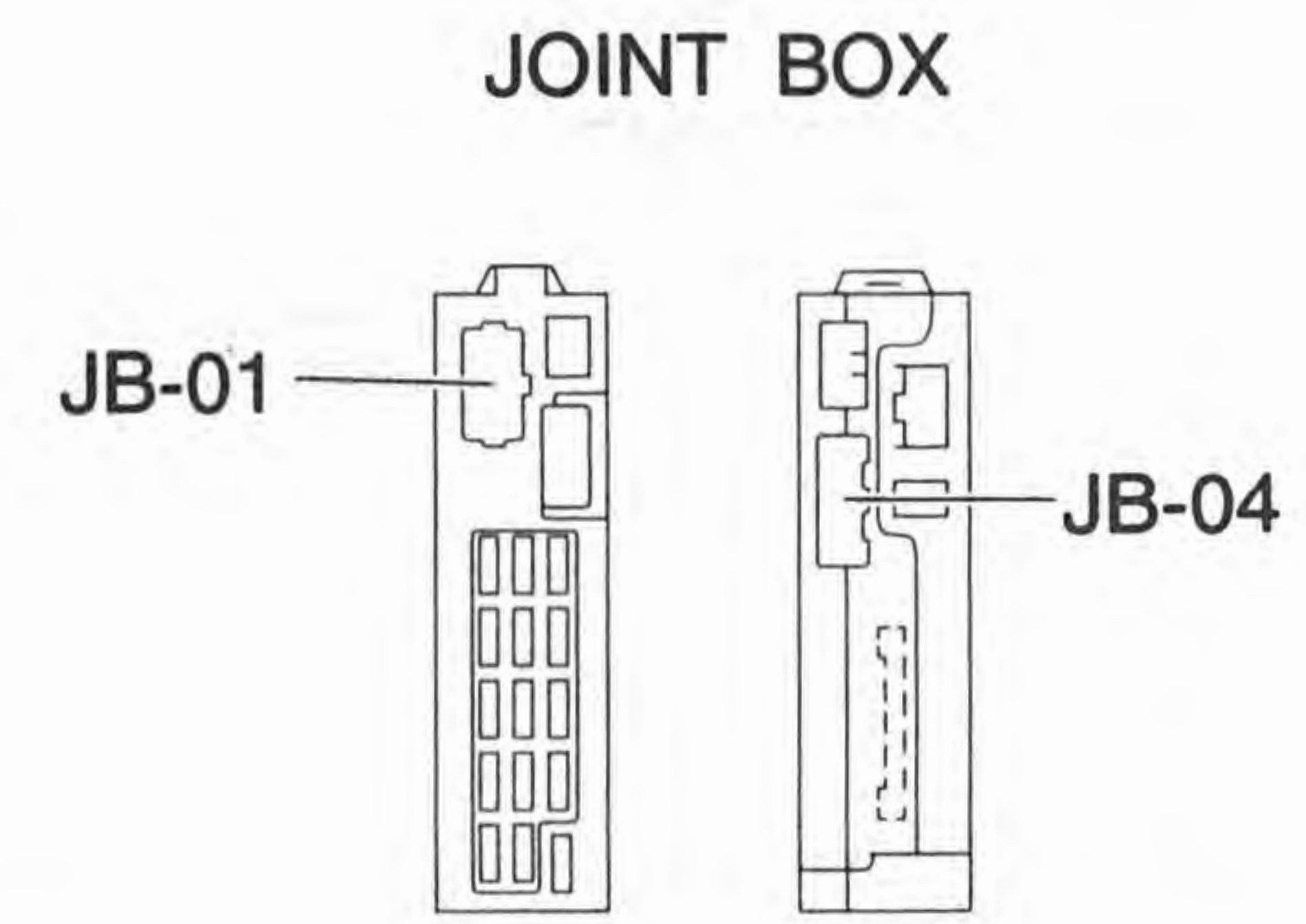
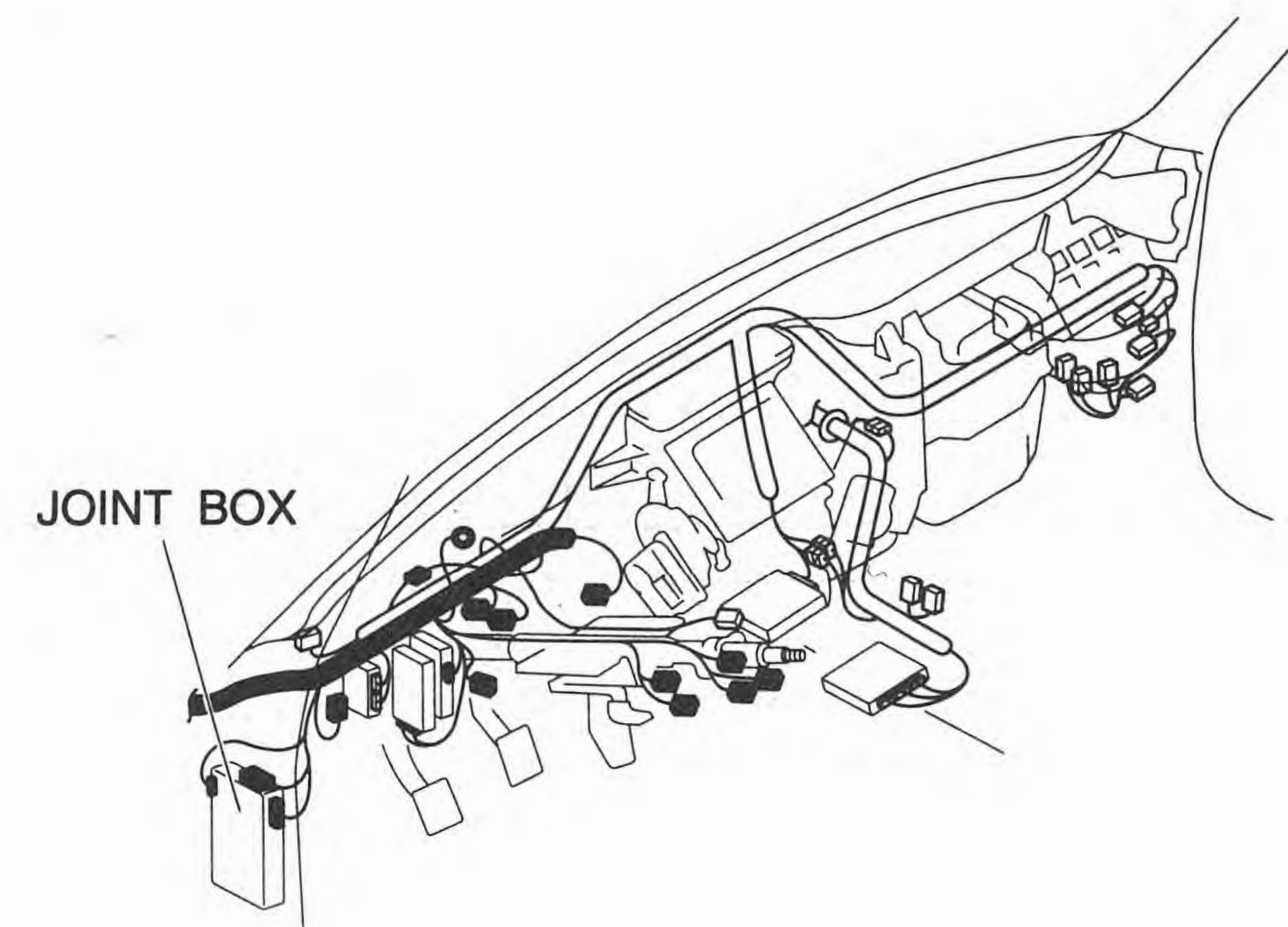
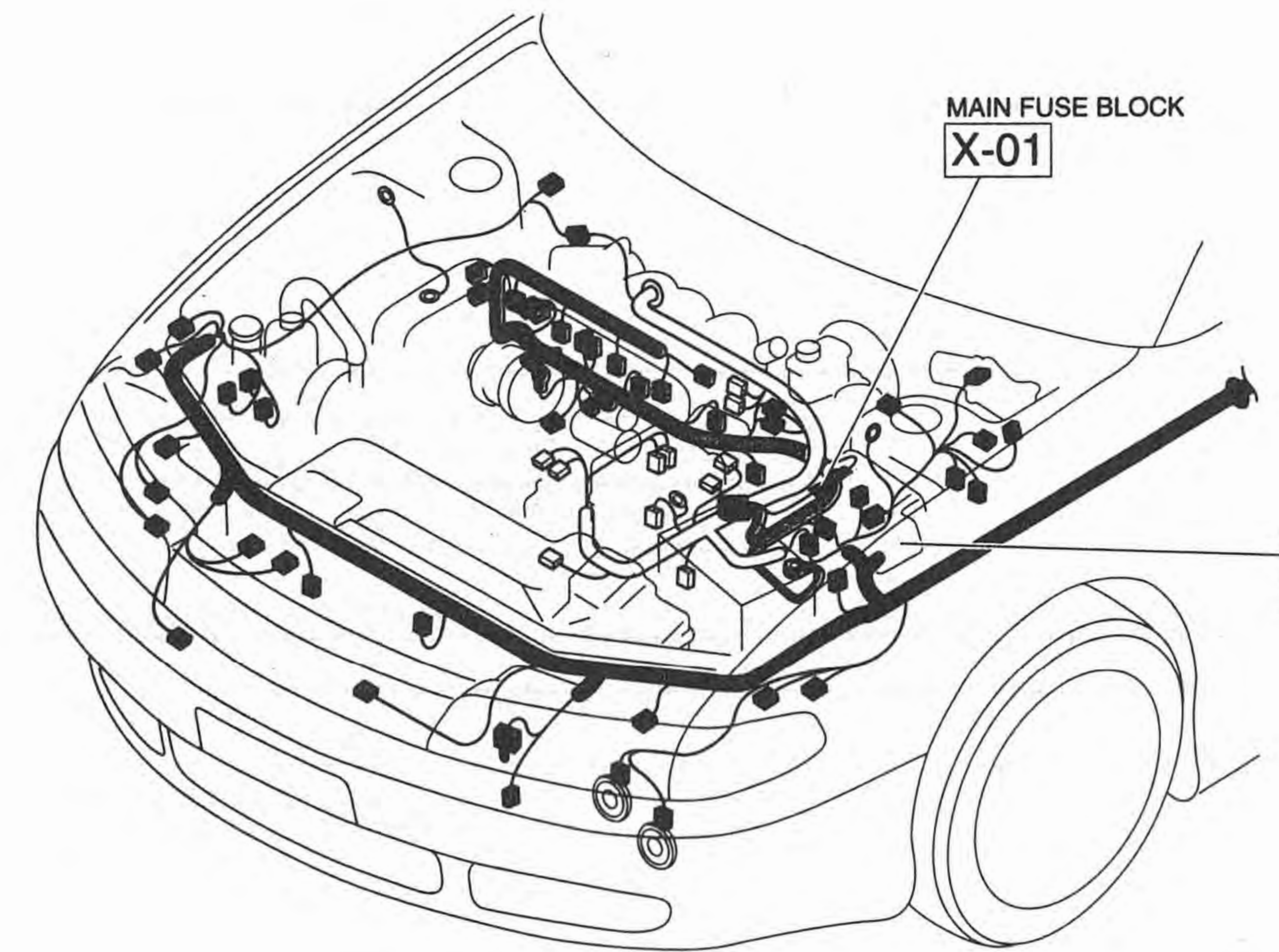

Q-1 EXCEPT FS ATX ■ CRUISE CONTROL SYSTEM

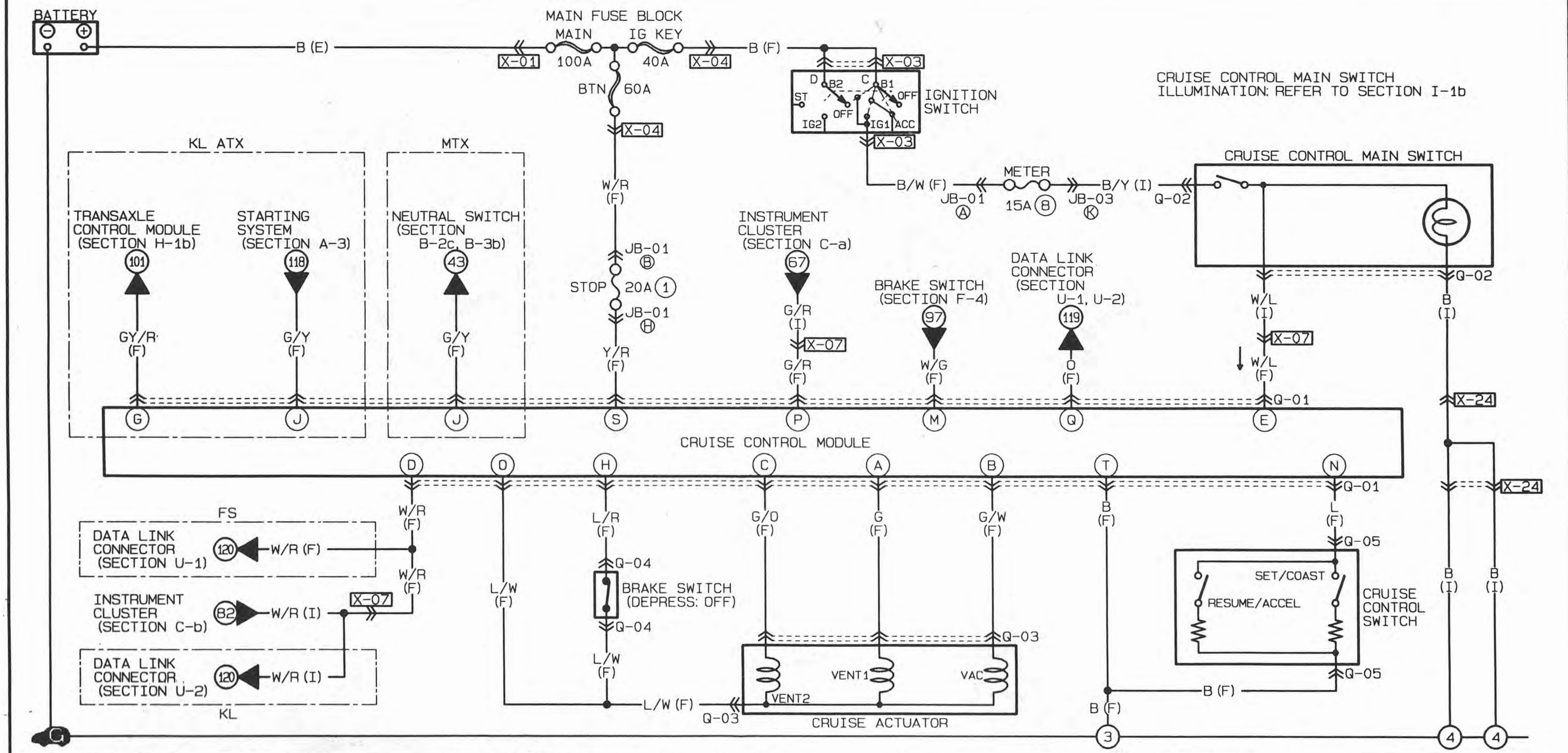

<p>Q-01 CRUISE CONTROL MODULE (F)</p> <table border="1"> <tr> <td>S</td><td>Q</td><td>O</td><td>M</td><td colspan="2">G</td><td>E</td><td>C</td><td>A</td> </tr> <tr> <td>Y/R</td><td>O</td><td>L/W</td><td>W/G</td><td colspan="2">* G/Y/R</td><td>W/L</td><td>G/O</td><td>G</td> </tr> <tr> <td>B</td><td>*</td><td>G/R</td><td>L</td><td>*</td><td>G/Y</td><td>L/R</td><td>W</td><td>W/R</td> </tr> <tr> <td>T</td><td>R</td><td>P</td><td>N</td><td>L</td><td>J</td><td>H</td><td>F</td><td>D</td> </tr> </table>	S	Q	O	M	G		E	C	A	Y/R	O	L/W	W/G	* G/Y/R		W/L	G/O	G	B	*	G/R	L	*	G/Y	L/R	W	W/R	T	R	P	N	L	J	H	F	D	<p>Q-02 CRUISE CONTROL MAIN SWITCH (I)</p> <table border="1"> <tr> <td>B</td><td>W/L</td><td>B/Y</td><td>GY</td><td>O</td> </tr> </table>	B	W/L	B/Y	GY	O	<p>Q-03 CRUISE ACTUATOR (F)</p> <table border="1"> <tr> <td>G/O</td><td>G/W</td><td>L/W</td><td>G</td> </tr> </table>	G/O	G/W	L/W	G	<p>Q-04 BRAKE SWITCH (F)</p> <table border="1"> <tr> <td>Y/R</td><td>L/R</td><td>W/G</td> </tr> <tr> <td>L/W</td><td>L/W</td><td>W/G</td> </tr> </table>	Y/R	L/R	W/G	L/W	L/W	W/G	<p>Q-05 CRUISE CONTROL SWITCH (F)</p> <table border="1"> <tr> <td>L</td><td>B</td><td>*</td> </tr> </table>	L	B	*
S	Q	O	M	G		E	C	A																																																		
Y/R	O	L/W	W/G	* G/Y/R		W/L	G/O	G																																																		
B	*	G/R	L	*	G/Y	L/R	W	W/R																																																		
T	R	P	N	L	J	H	F	D																																																		
B	W/L	B/Y	GY	O																																																						
G/O	G/W	L/W	G																																																							
Y/R	L/R	W/G																																																								
L/W	L/W	W/G																																																								
L	B	*																																																								

Q-1

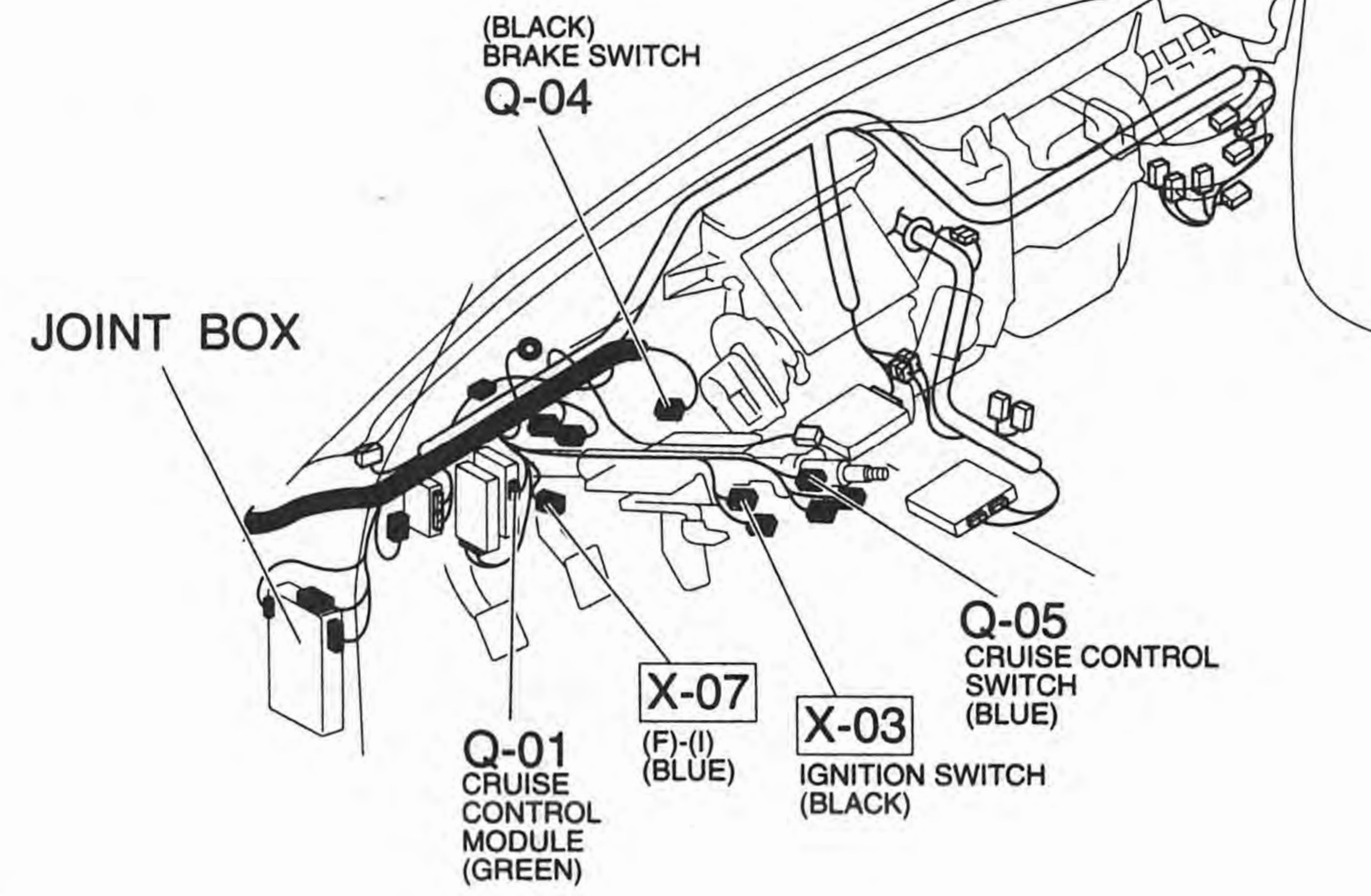
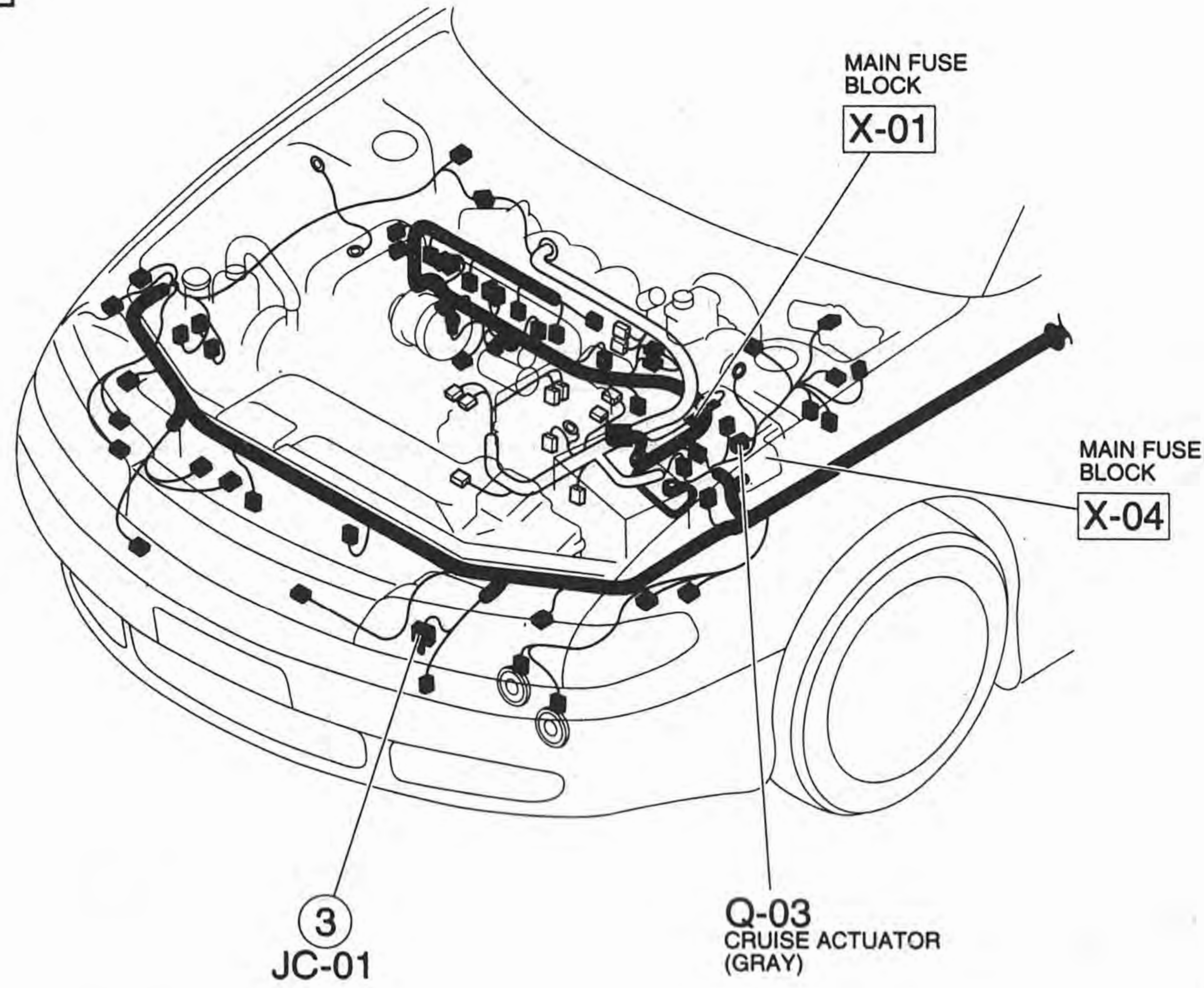

JOINT BOX

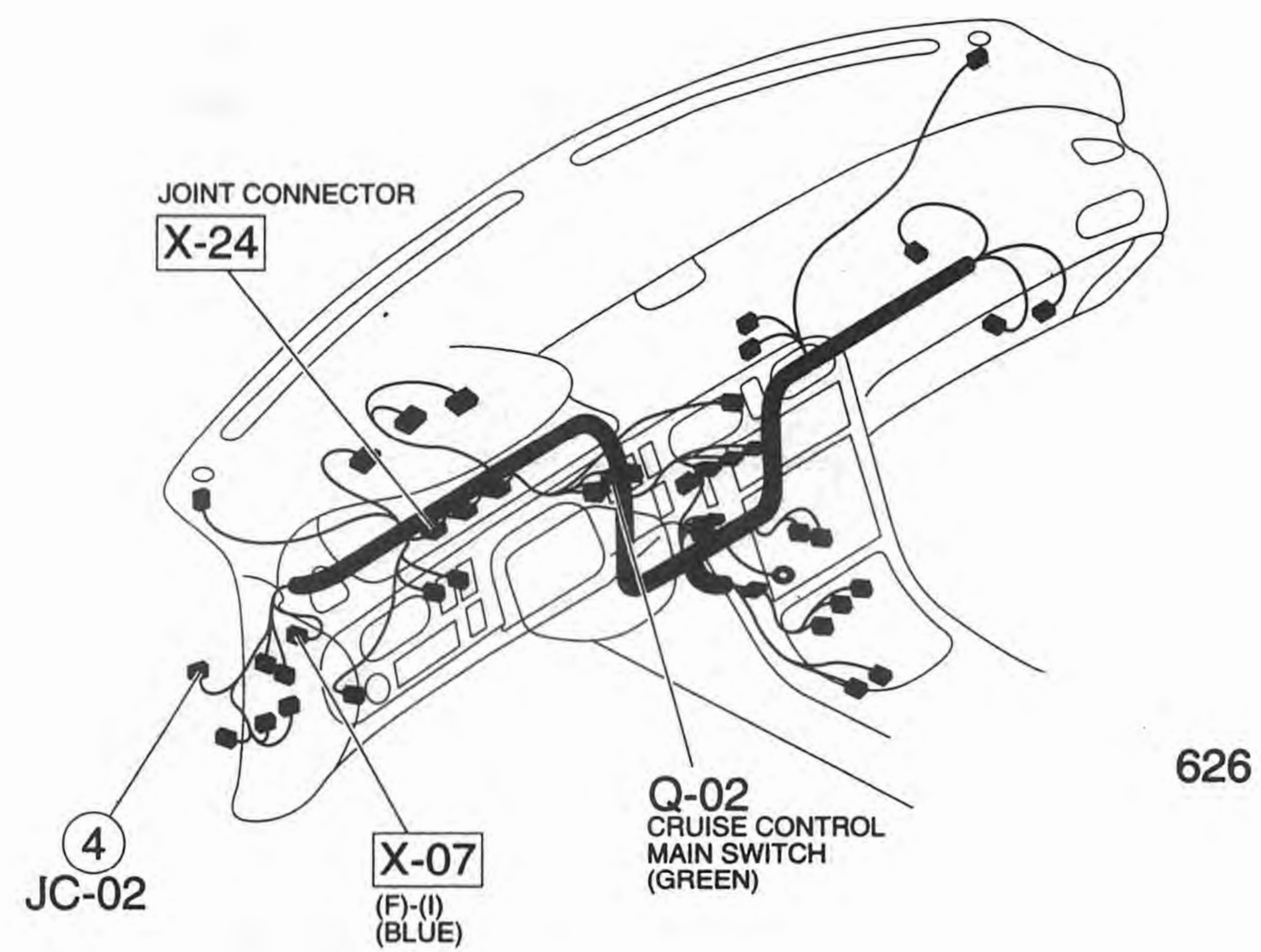
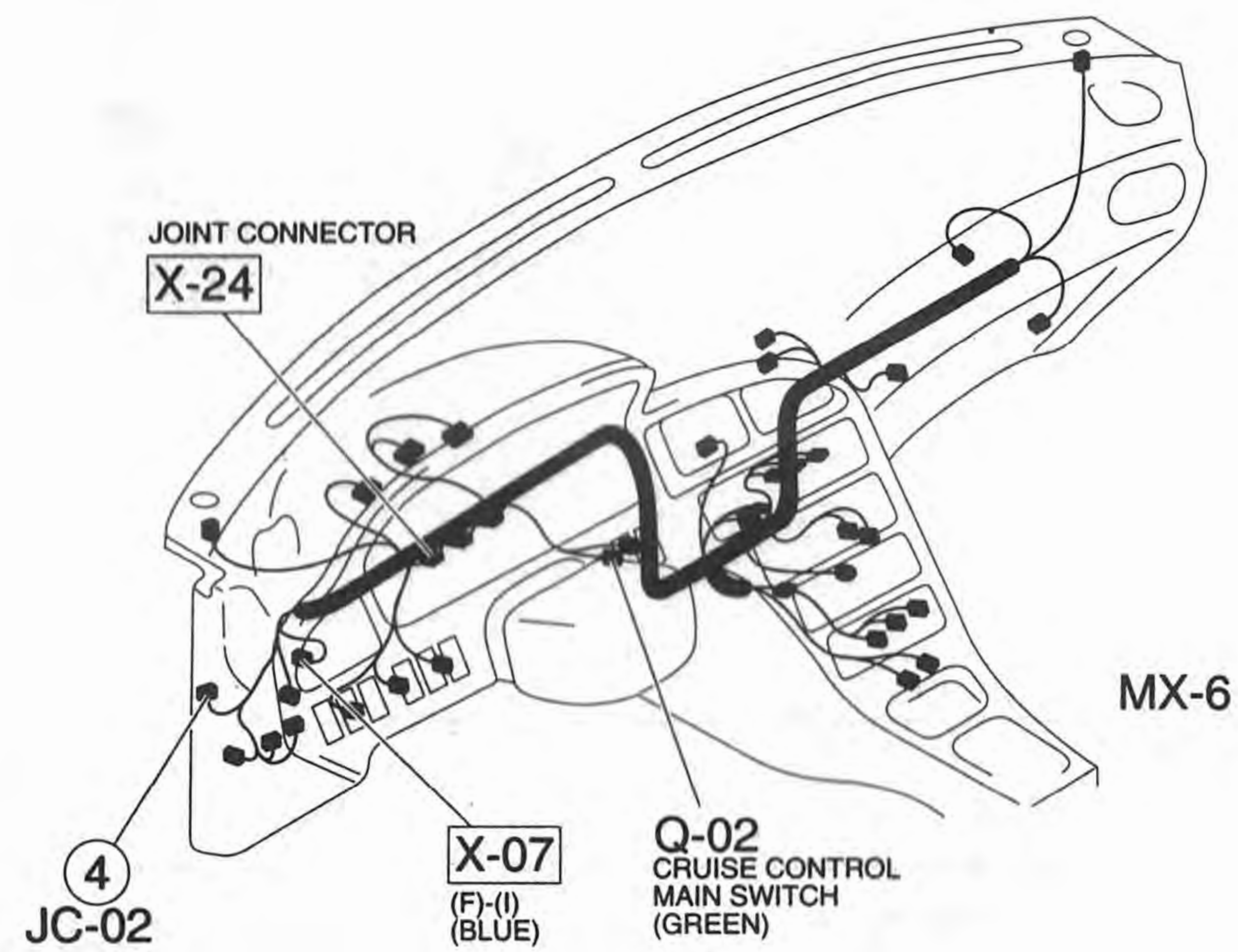
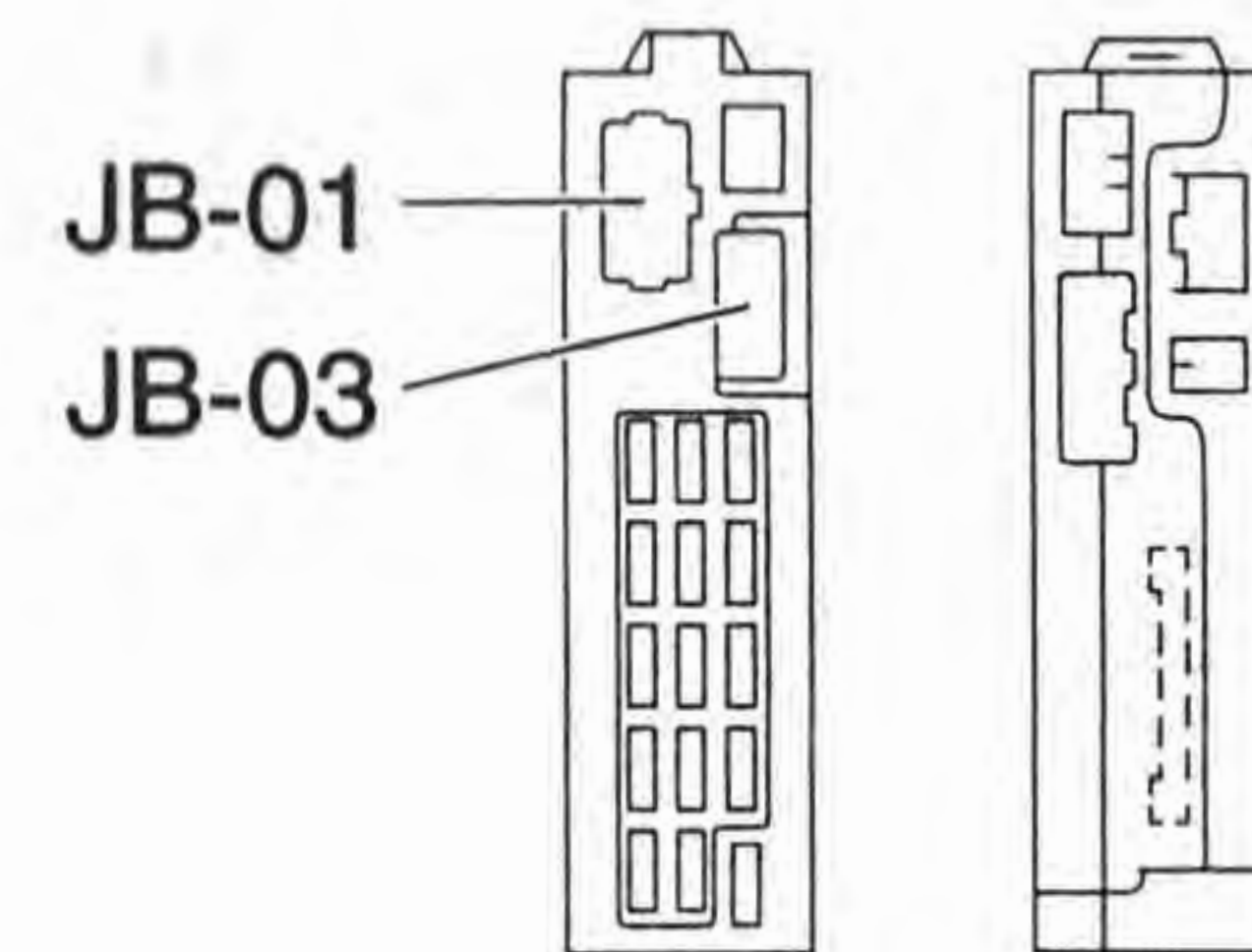

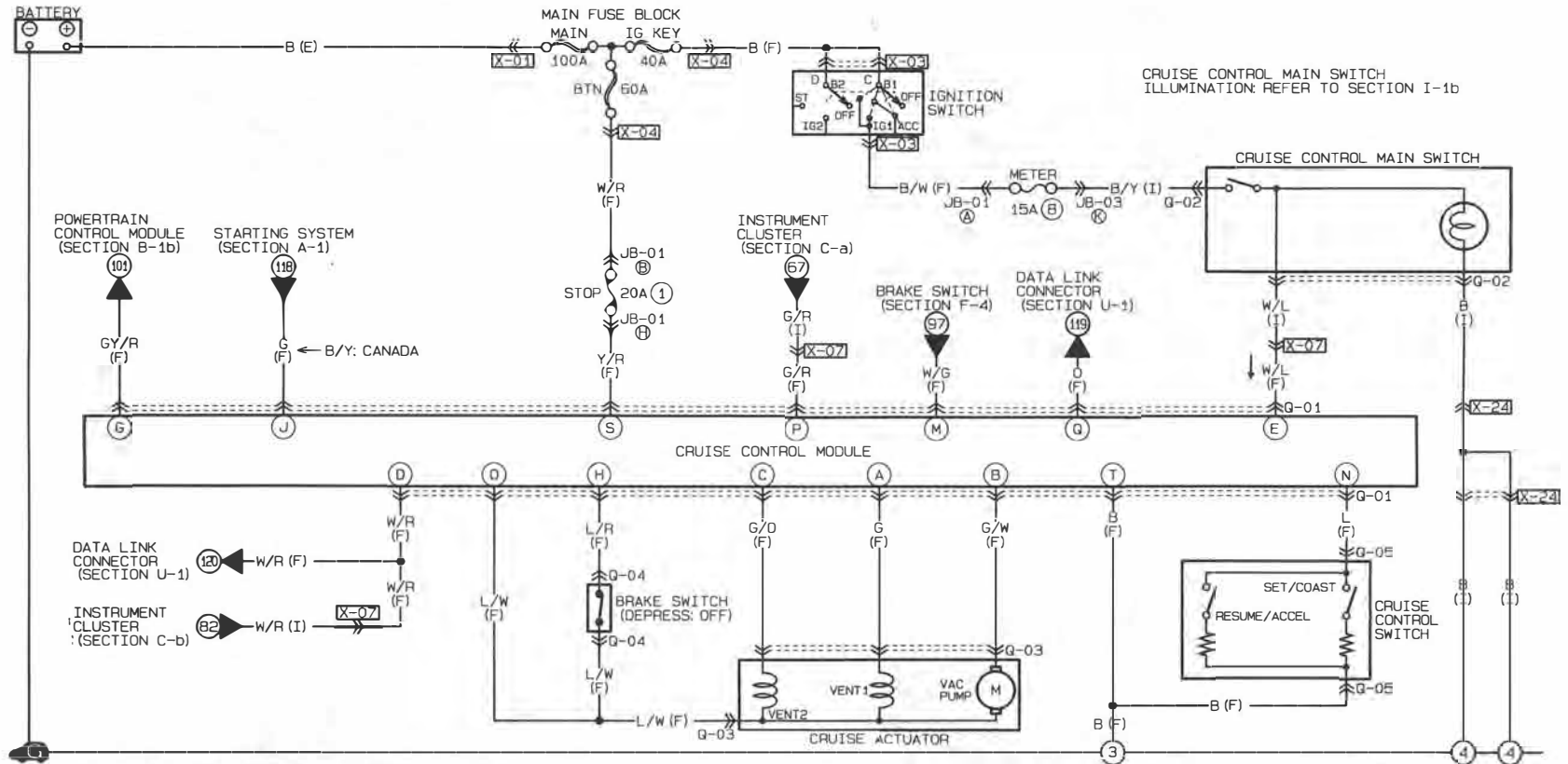

Q-01 CRUISE CONTROL MODULE (F)

S	Q	D	M			G	E	C	A
Y/R	D	L/W	W/G			Gy/R	W/L	G/D	G
B	*	G/R	L	*	G	L/R	W	W/R	G/W
T	R	P	N	L	J	H	F	D	B

Q-02 CRUISE CONTROL MAIN SWITCH (I)

B	W/L	B/Y	Gy	D
---	-----	-----	----	---

Q-03 CRUISE ACTUATOR (F)

L/W	G
G/D	G/W

Q-04 BRAKE SWITCH (F)

Y/R	L/R	W/G
L/W	W/G	

Q-05 CRUISE CONTROL SWITCH (F)

L	B	W
---	---	---

Q-2

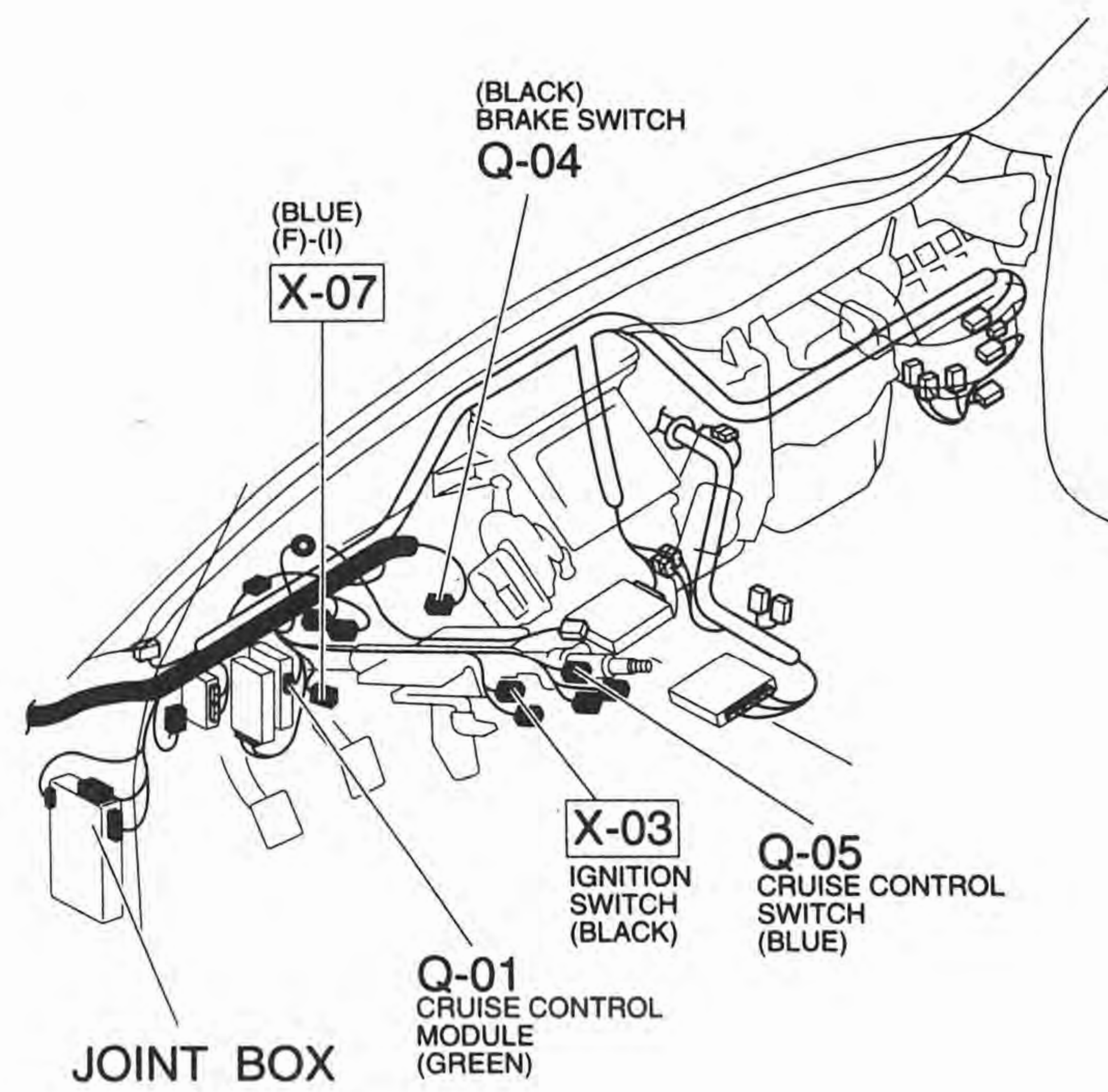
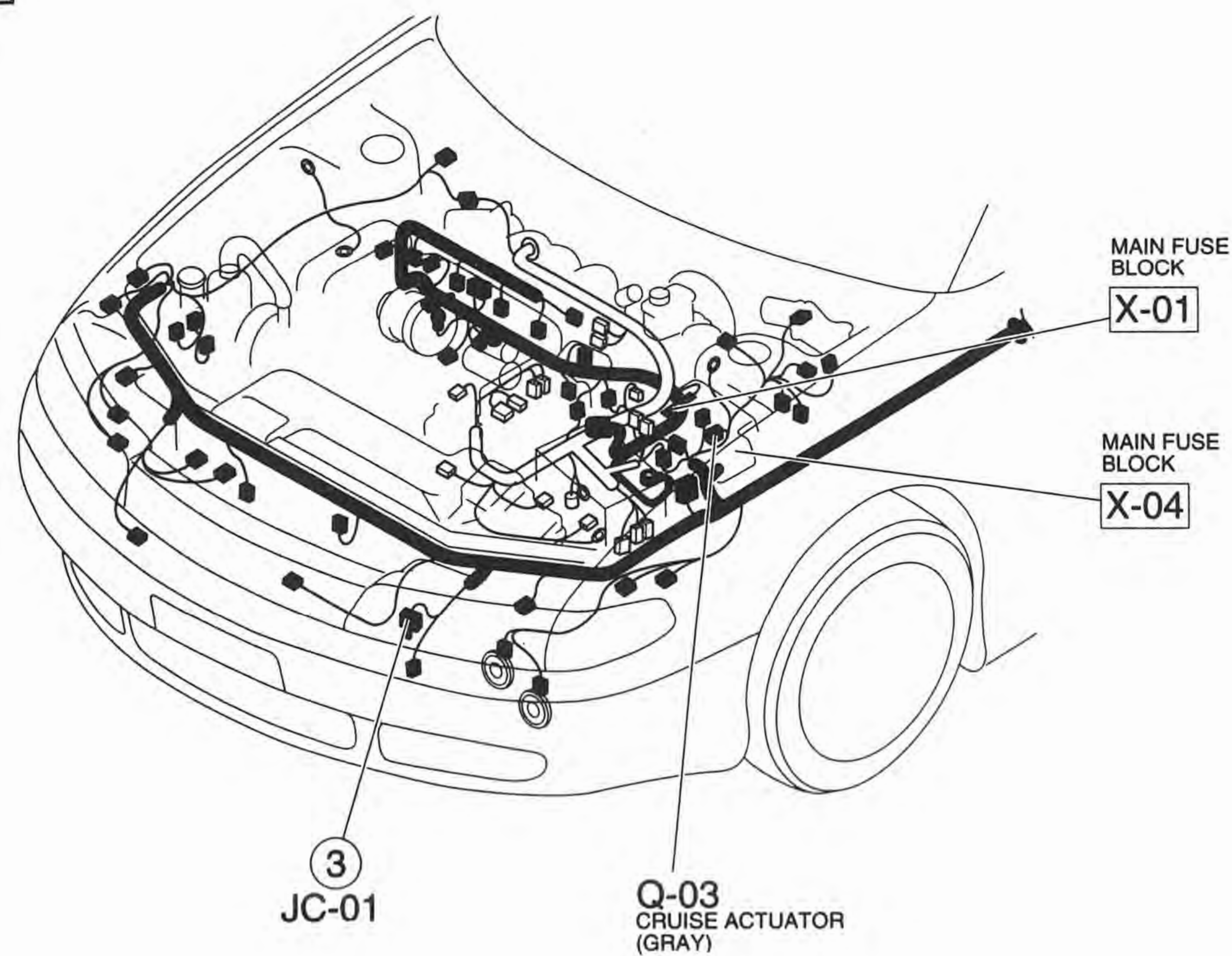

JOINT BOX

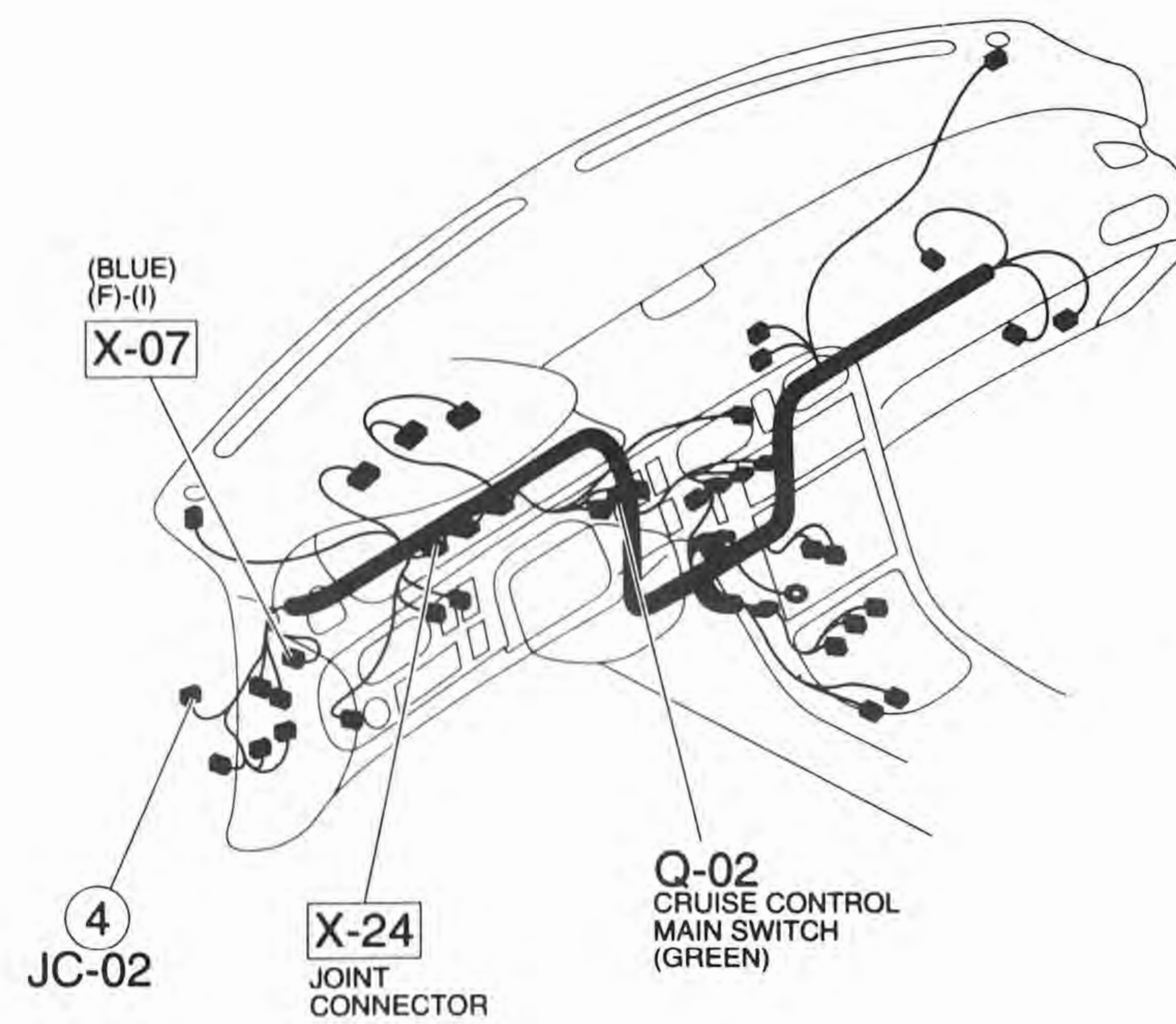
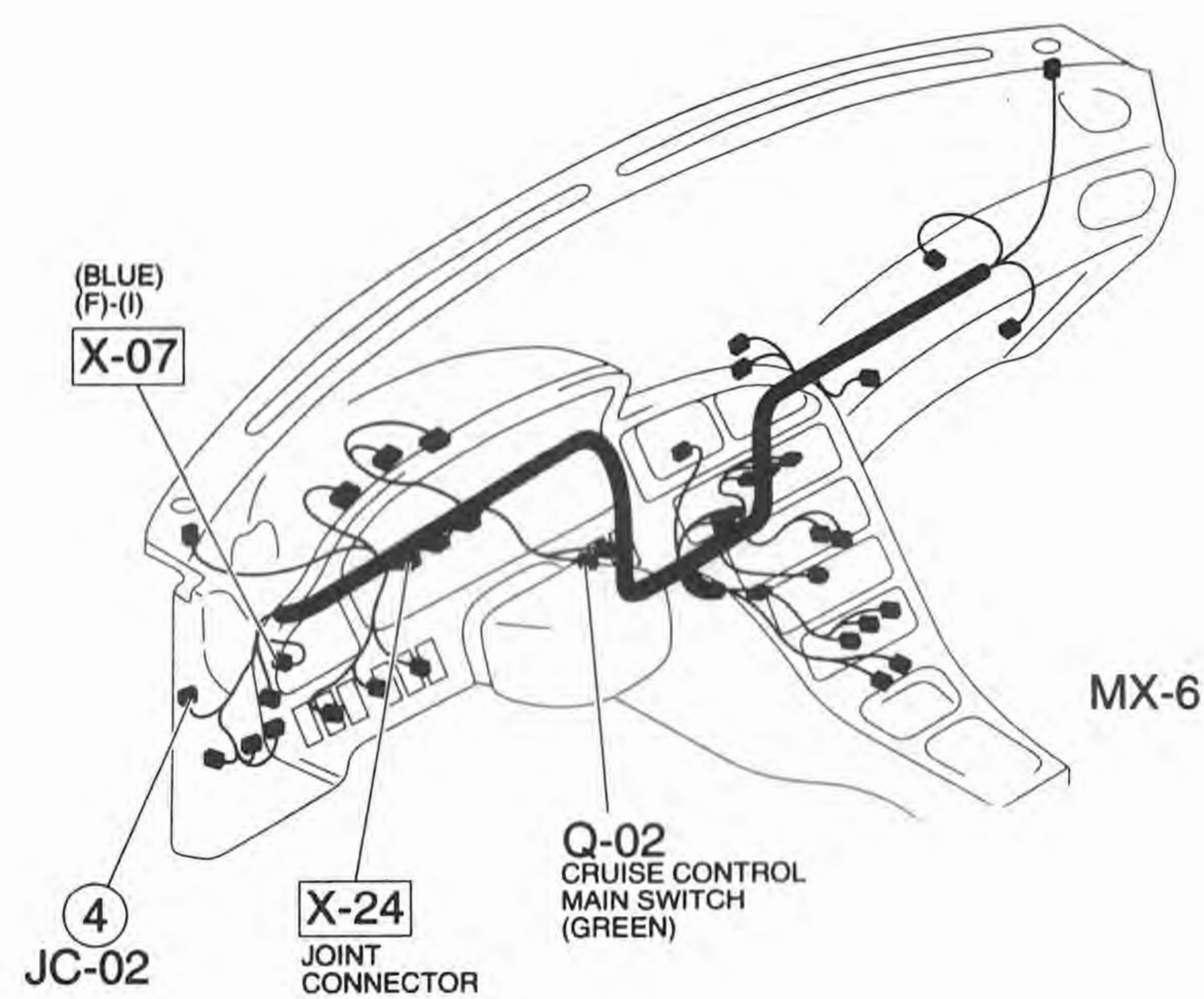
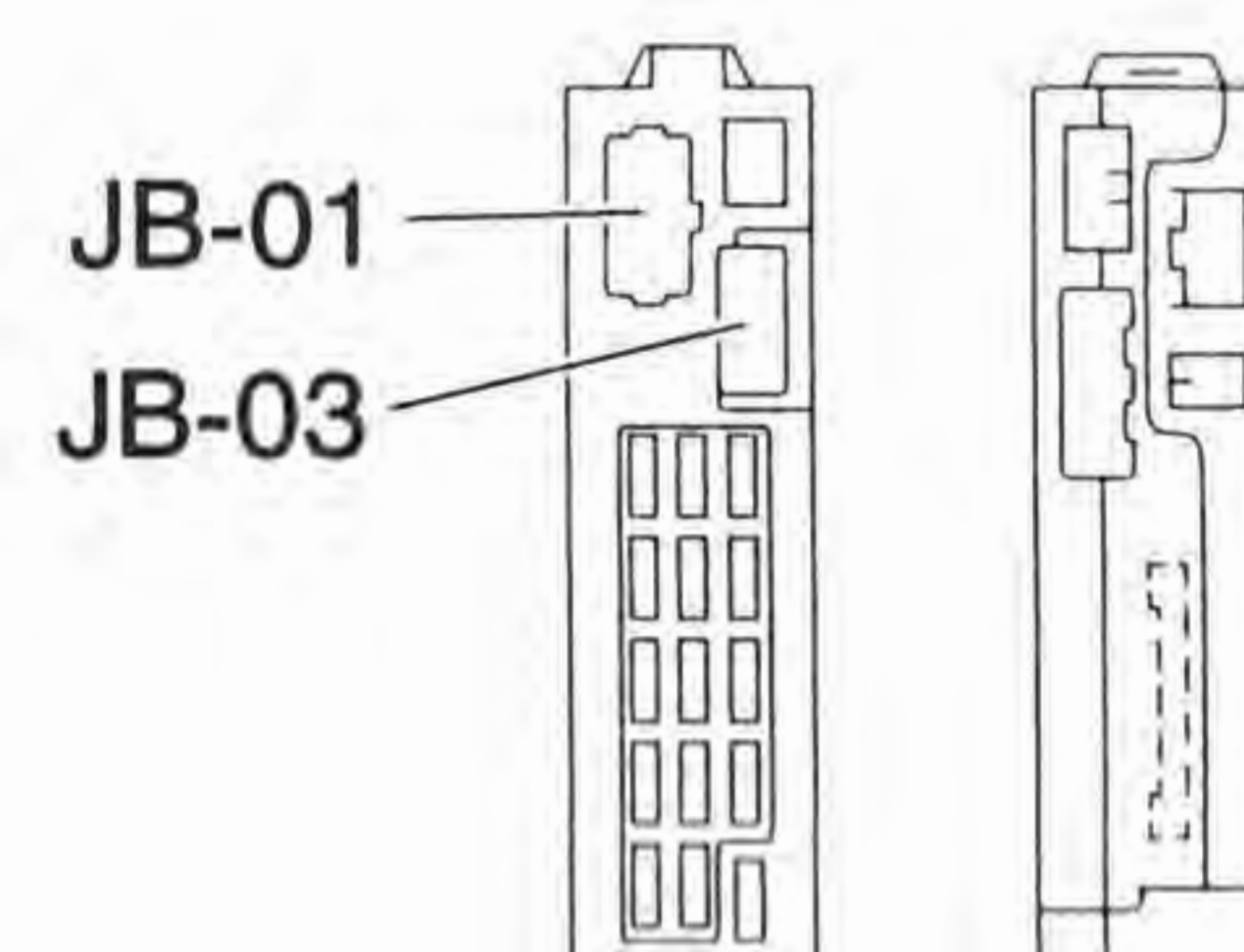

626

BLANK DIVIDER

Z-160

S

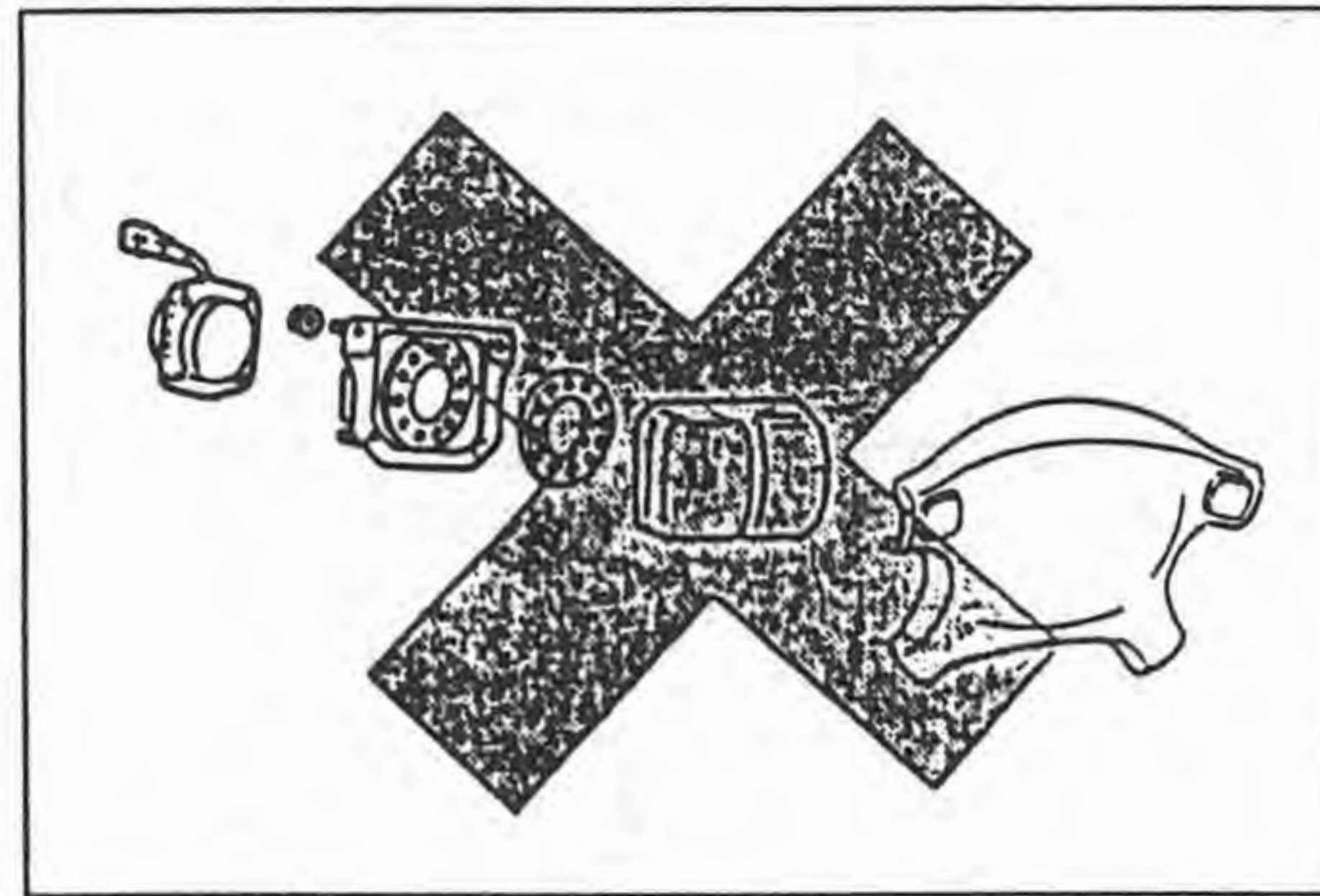

SERVICE WARNINGS

Component Disassembly

- Disassembling and reassembling the components of the air bag system can render the system inoperative, which may result in serious injury or death in the event of an accident. Do not disassemble any air bag system components.

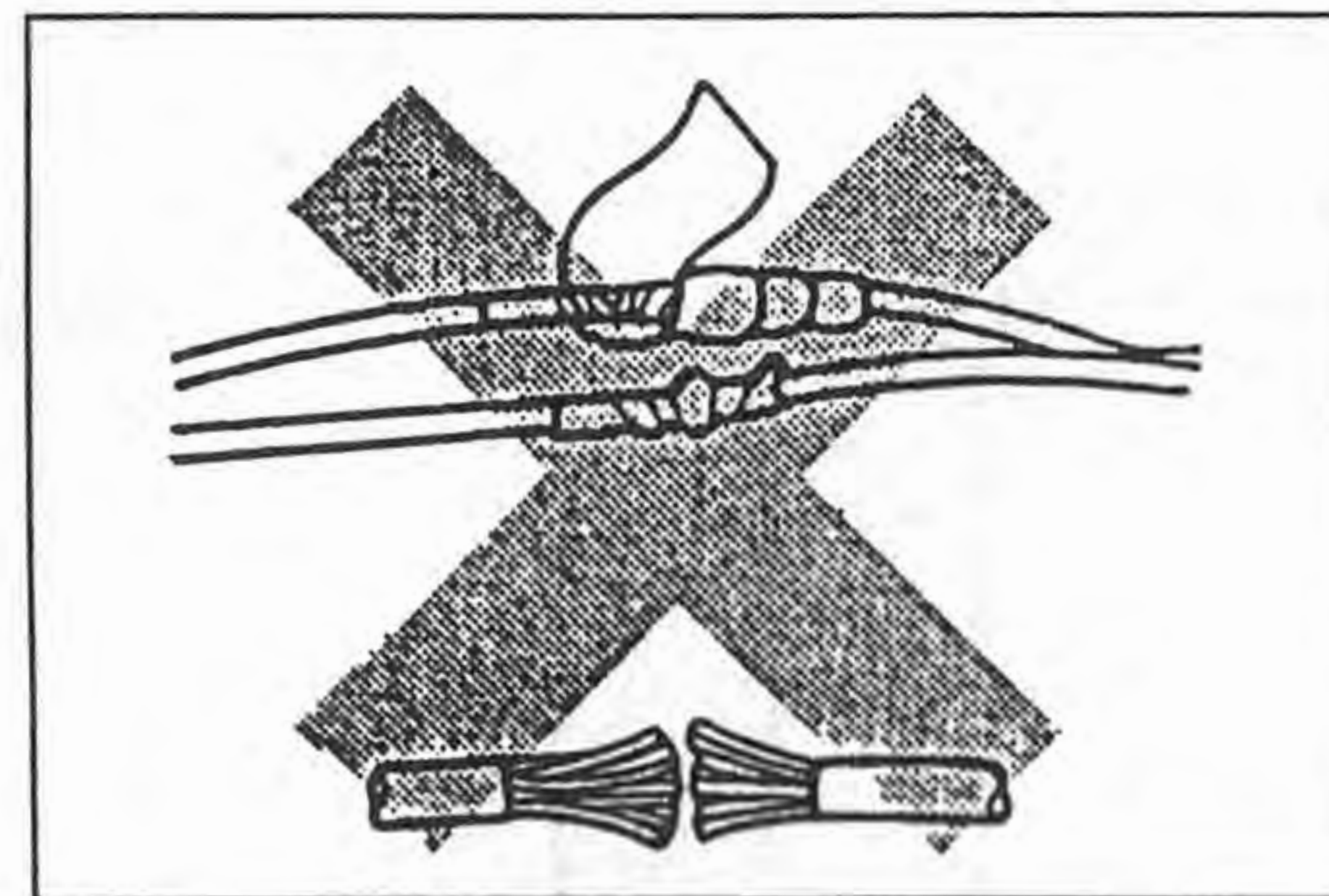

Wiring Harness Repair

- Incorrectly repairing an air bag system wiring harness can accidentally deploy the air bag, which can cause serious injury. If a problem is found in the system wiring, replace the wiring harness. Do not try to repair it.

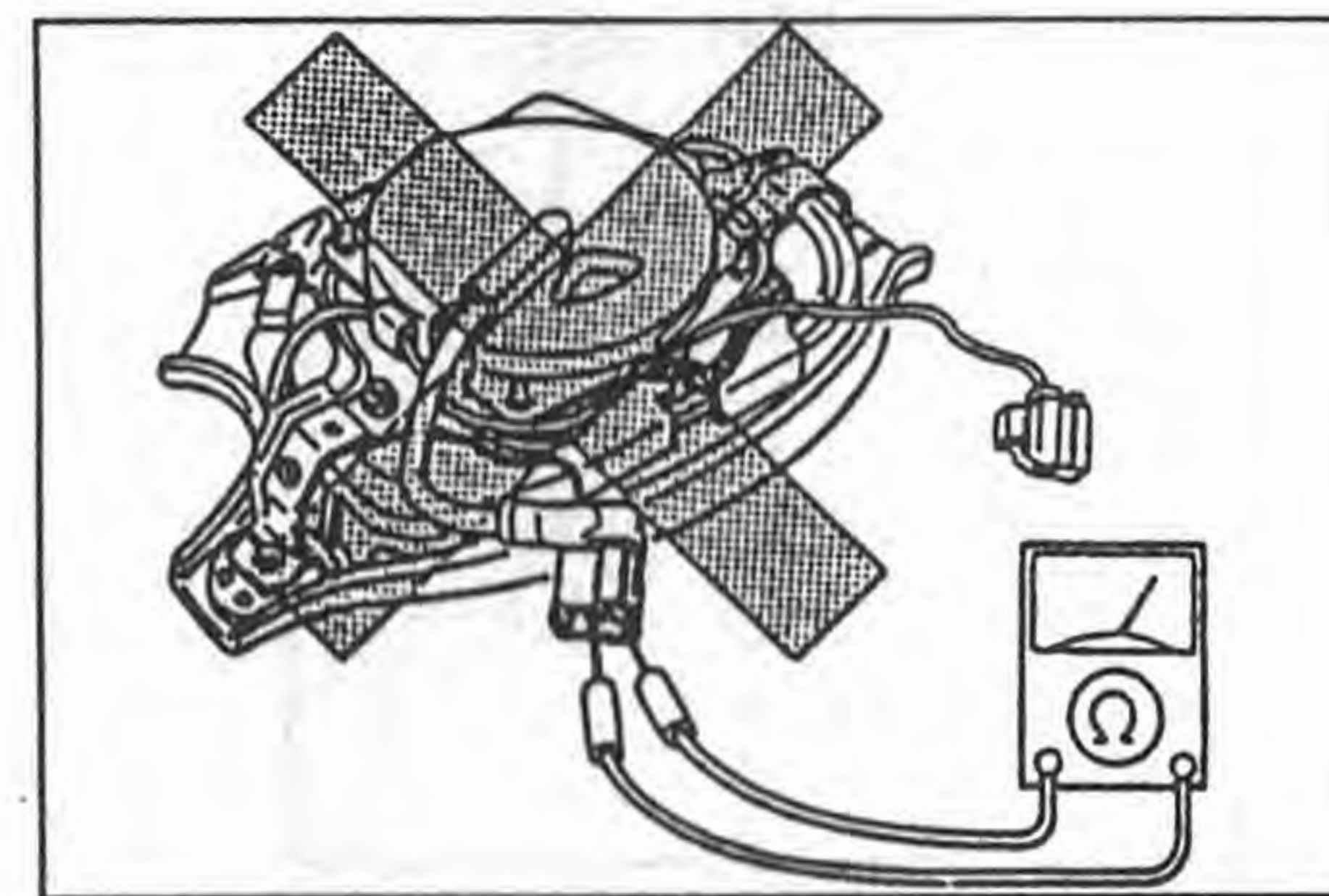

Air Bag Module Inspection

- Inspecting the air bag module with an ohmmeter can deploy the air bag, which can cause serious injury. Do not use an ohmmeter to inspect the air bag module.

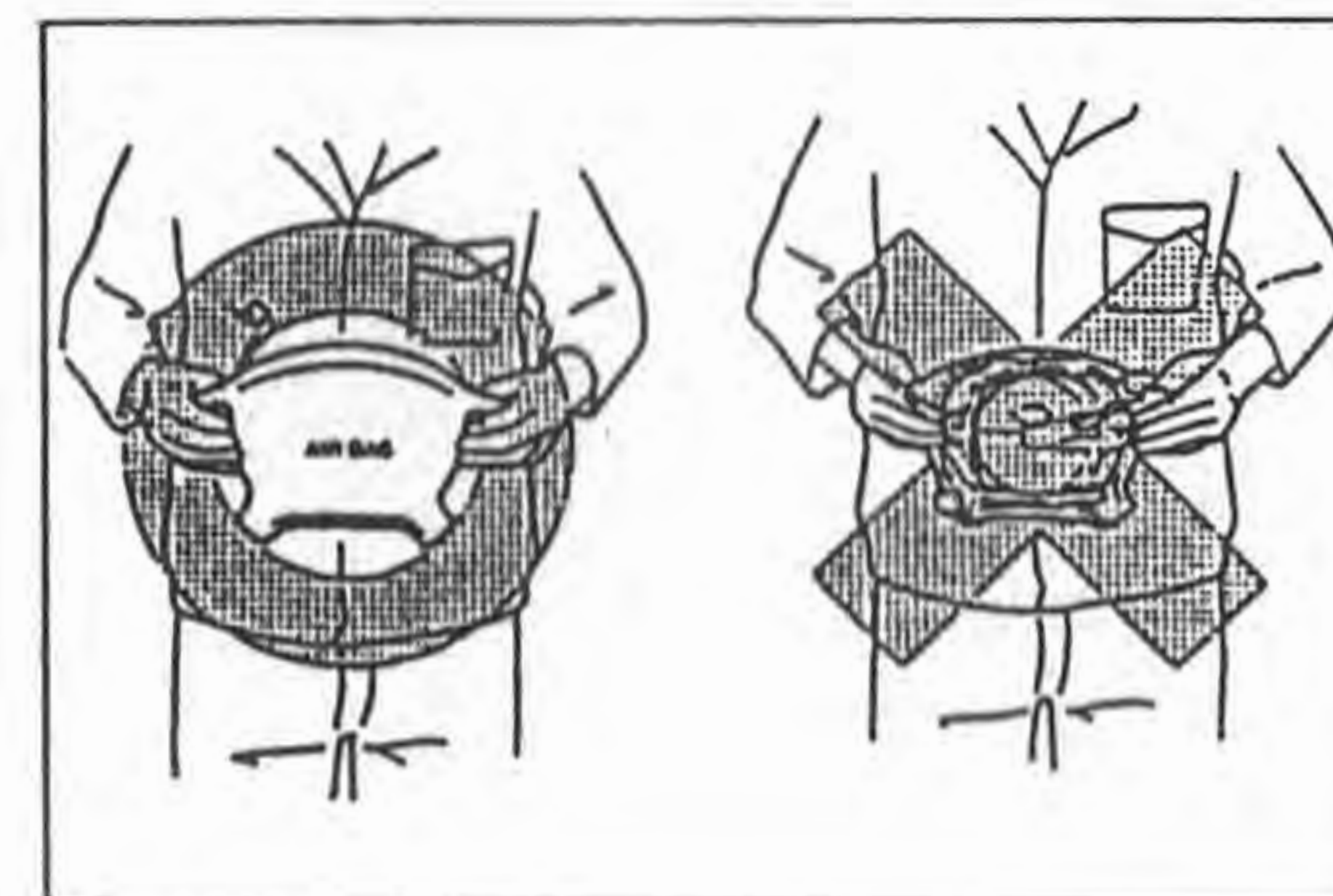

Air Bag Module Handling

- A live (undeployed) air bag may accidentally deploy when it is handled and cause serious injury. When carrying a live air bag module, point the trim cover away from your body to lessen the chance of injury in case it deploys.

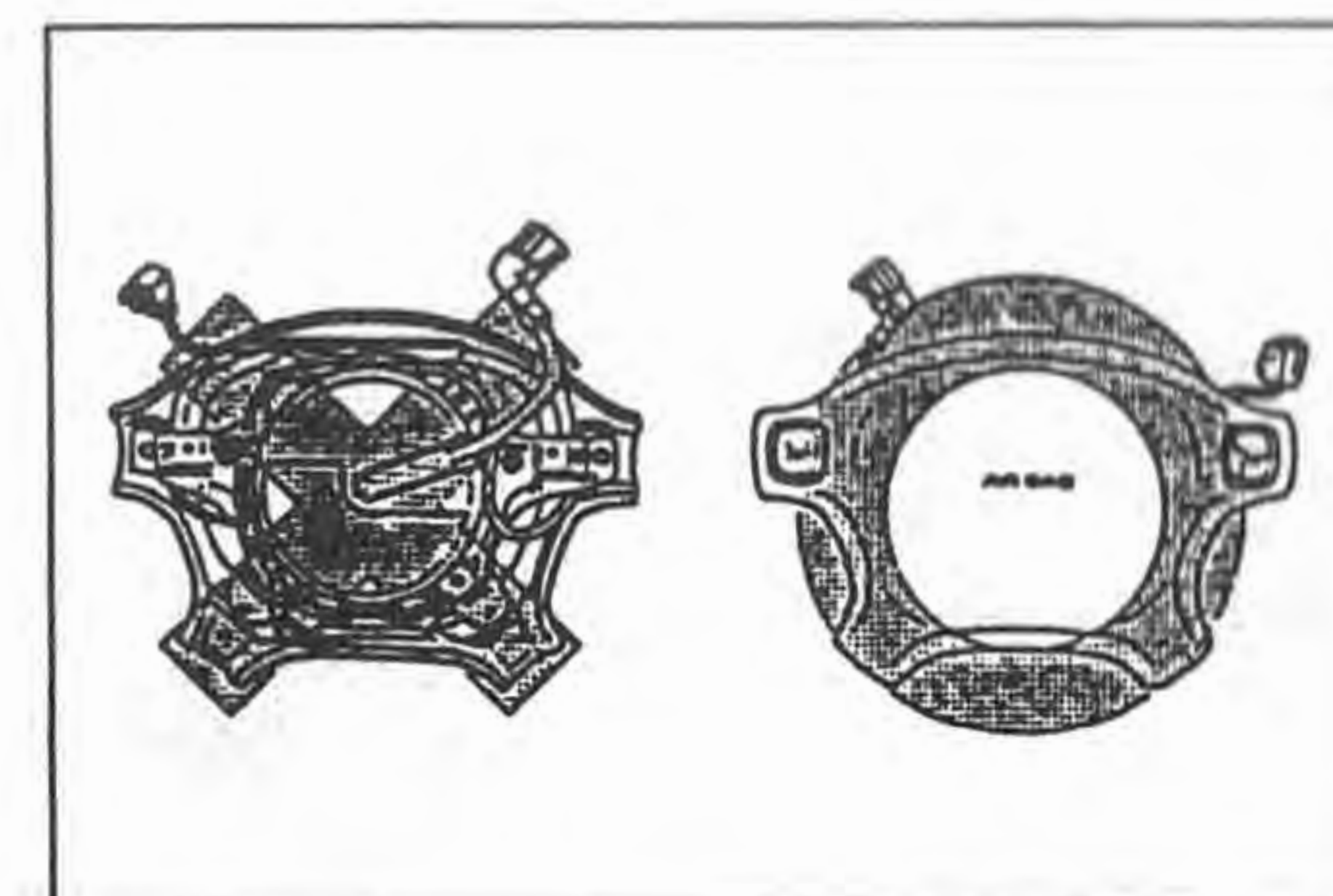

- A live air bag placed face down on a surface is dangerous. If the air bag deploys, the motion of the module can cause serious injury. Always face the trim cover up to reduce the motion of the module in case it accidentally deploys.

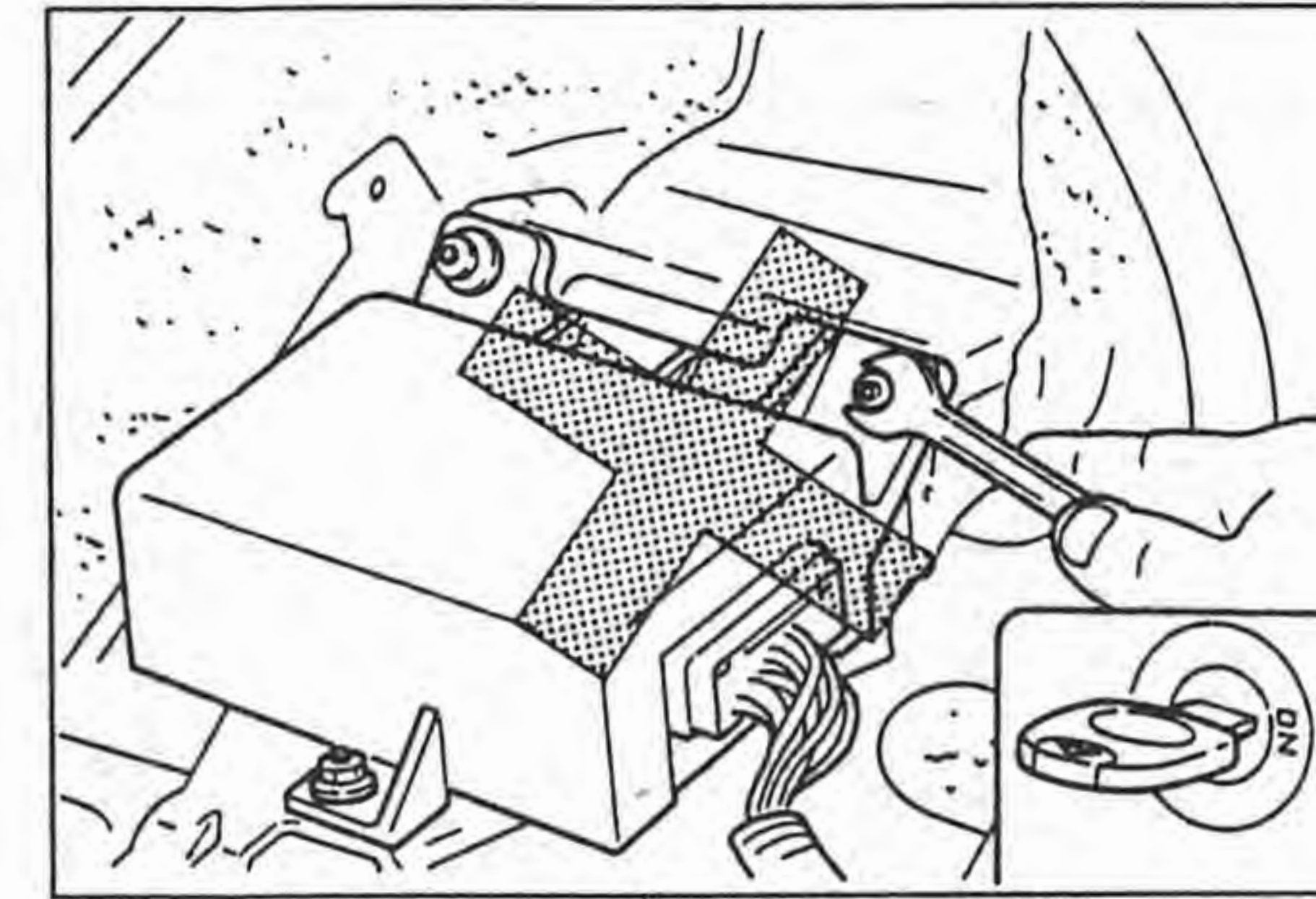

SAS-unit Handling

- Disconnecting the SAS-unit connector or removing the SAS-unit with the ignition switch at ON can cause the air bag to deploy, which may seriously injure you. Before disconnecting the SAS-unit connector or removing the SAS-unit, turn the ignition switch to LOCK.

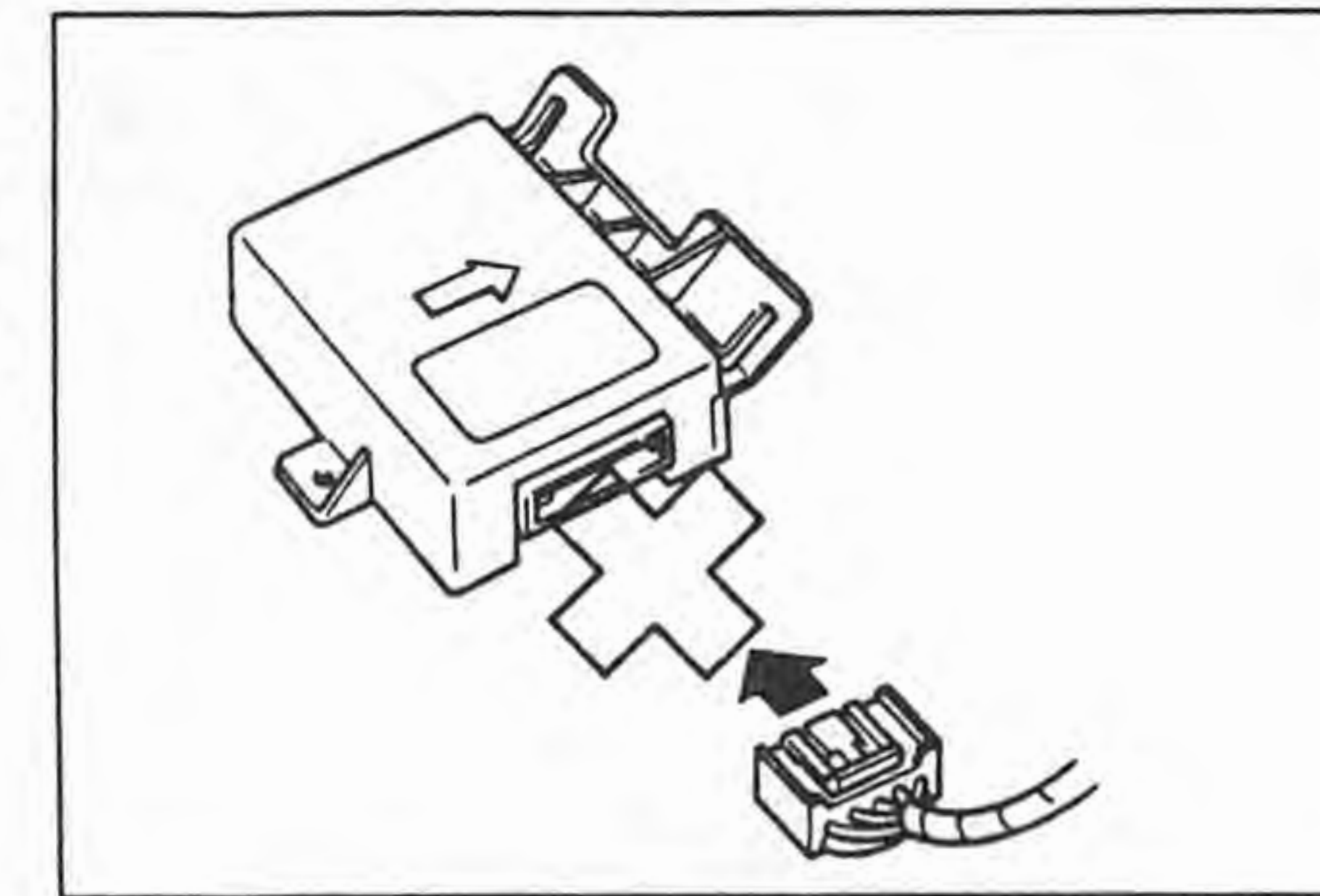

- Connecting the SAS-unit connector before installing the SAS-unit is dangerous. The shock of installation can cause the air bag to deploy, which may seriously injure you. Before connecting the SAS-unit connector, firmly mount the SAS-unit to the vehicle.

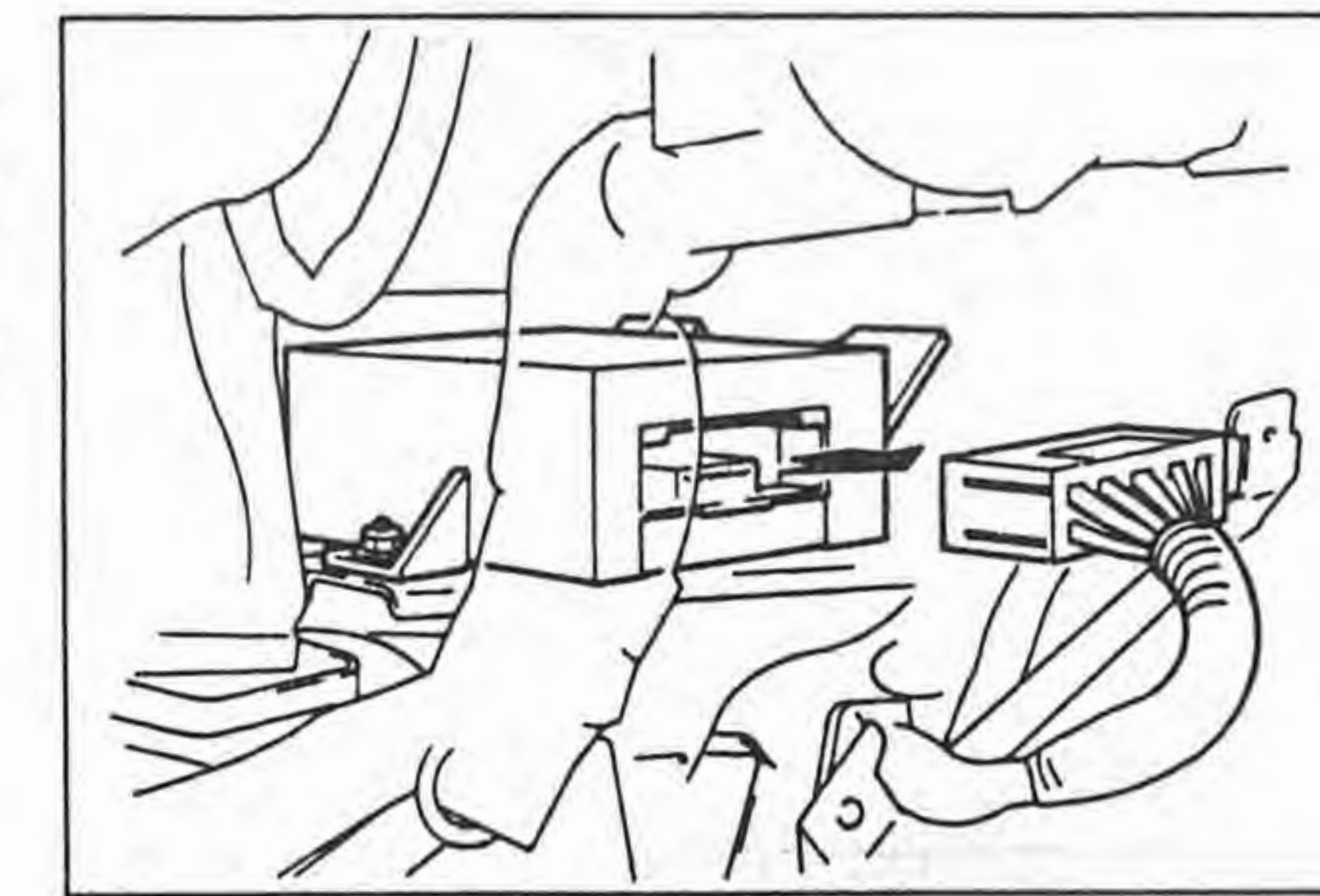

GENERAL PROCEDURES

Before Servicing

1. Turn the ignition switch to LOCK.
2. Disconnect the negative battery cable.
3. Disconnect the SAS-unit connector.

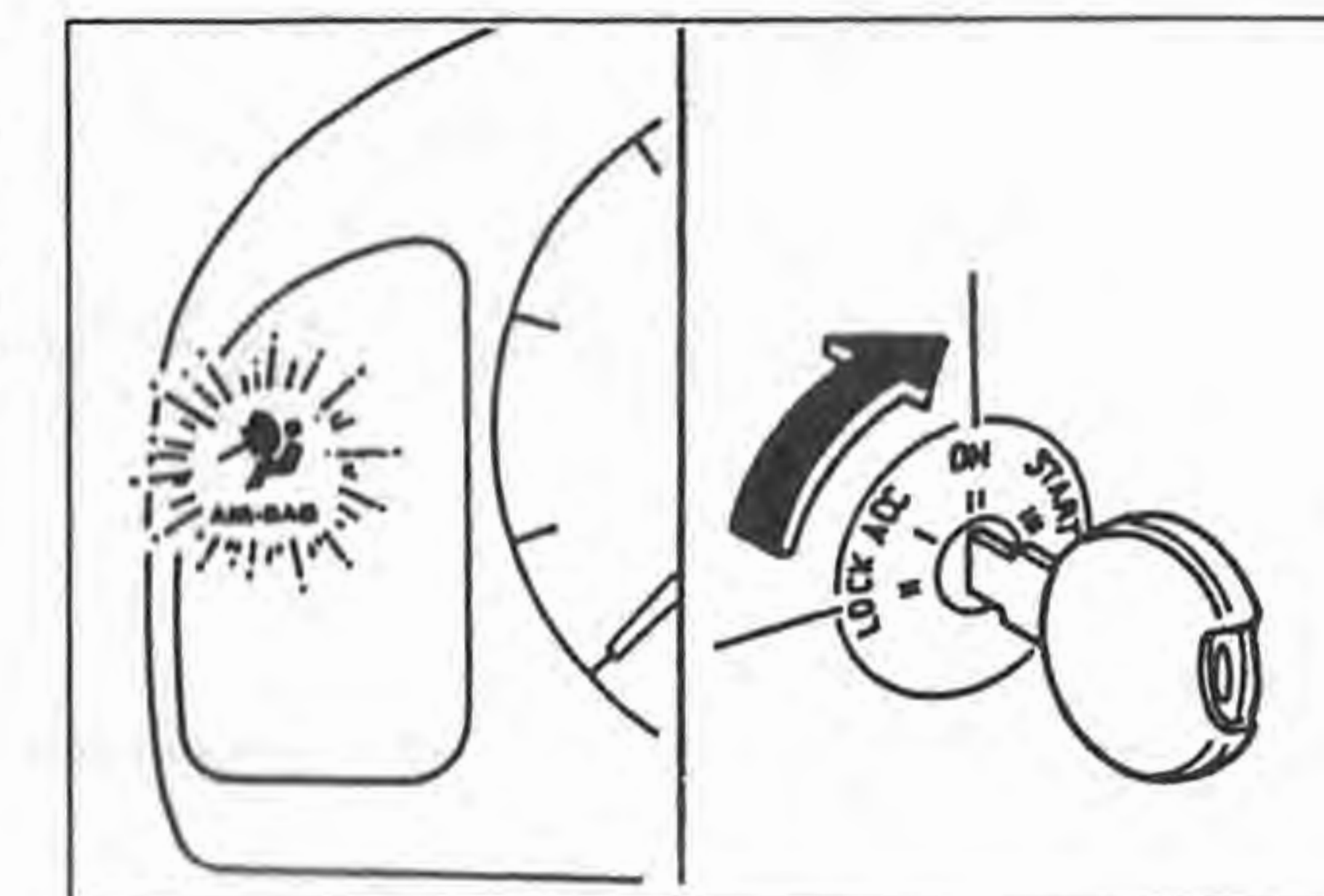

After Servicing

1. Connect the negative battery cable.
2. Turn the ignition switch to ON.
3. Verify that the air bag system warning light illuminates for 4—8 seconds and then goes off.

Z WIRING DIAGRAM

S AIR BAG SYSTEM

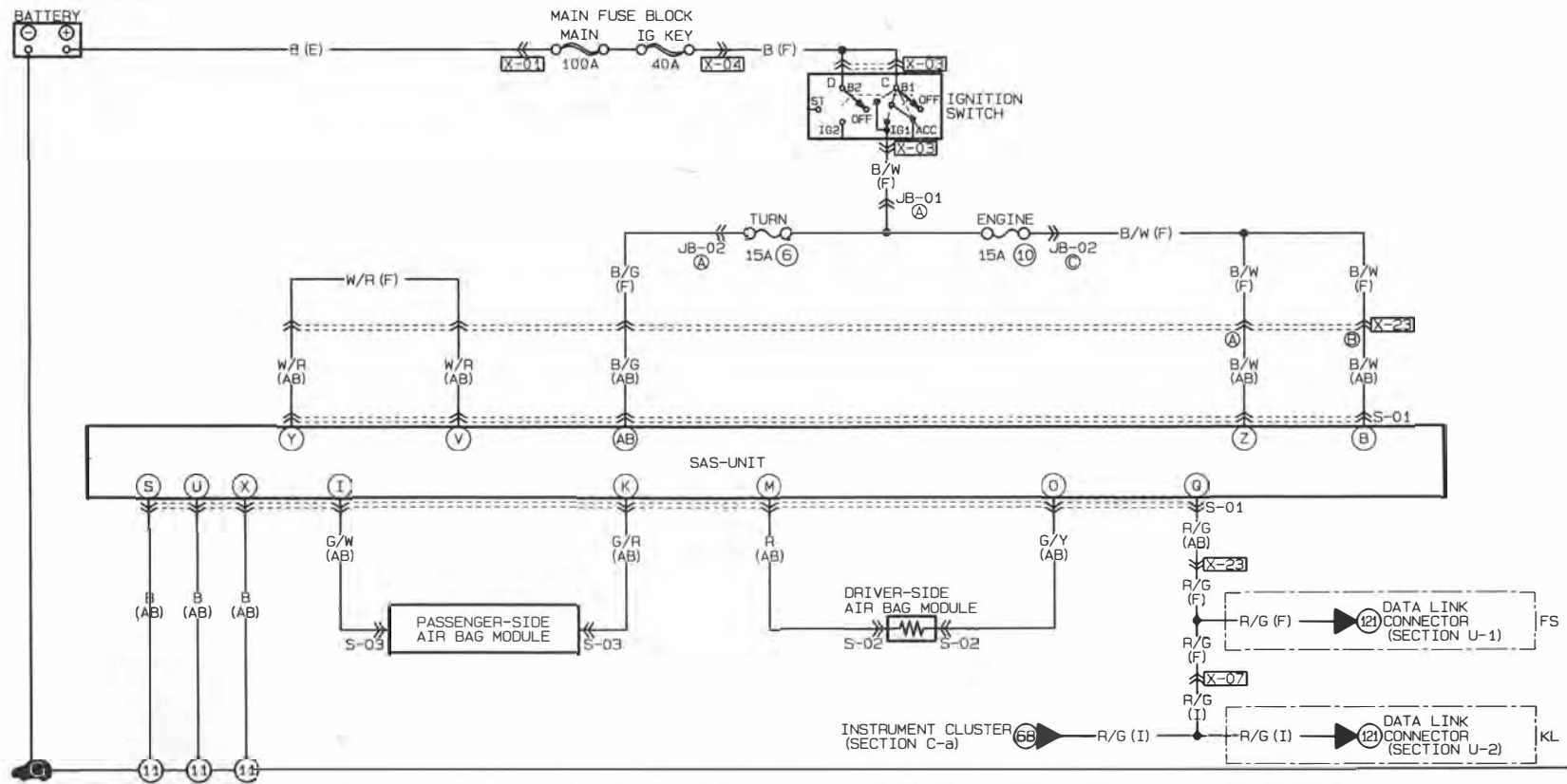

S-01 SAS-UNIT (AB)

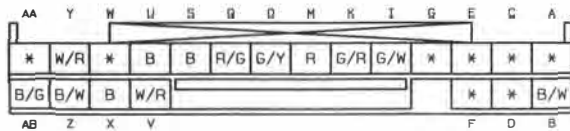

S-02 DRIVER-SIDE AIR BAG MODULE (AB)



S-03 PASSENGER-SIDE AIR BAG MODULE (AB)



S

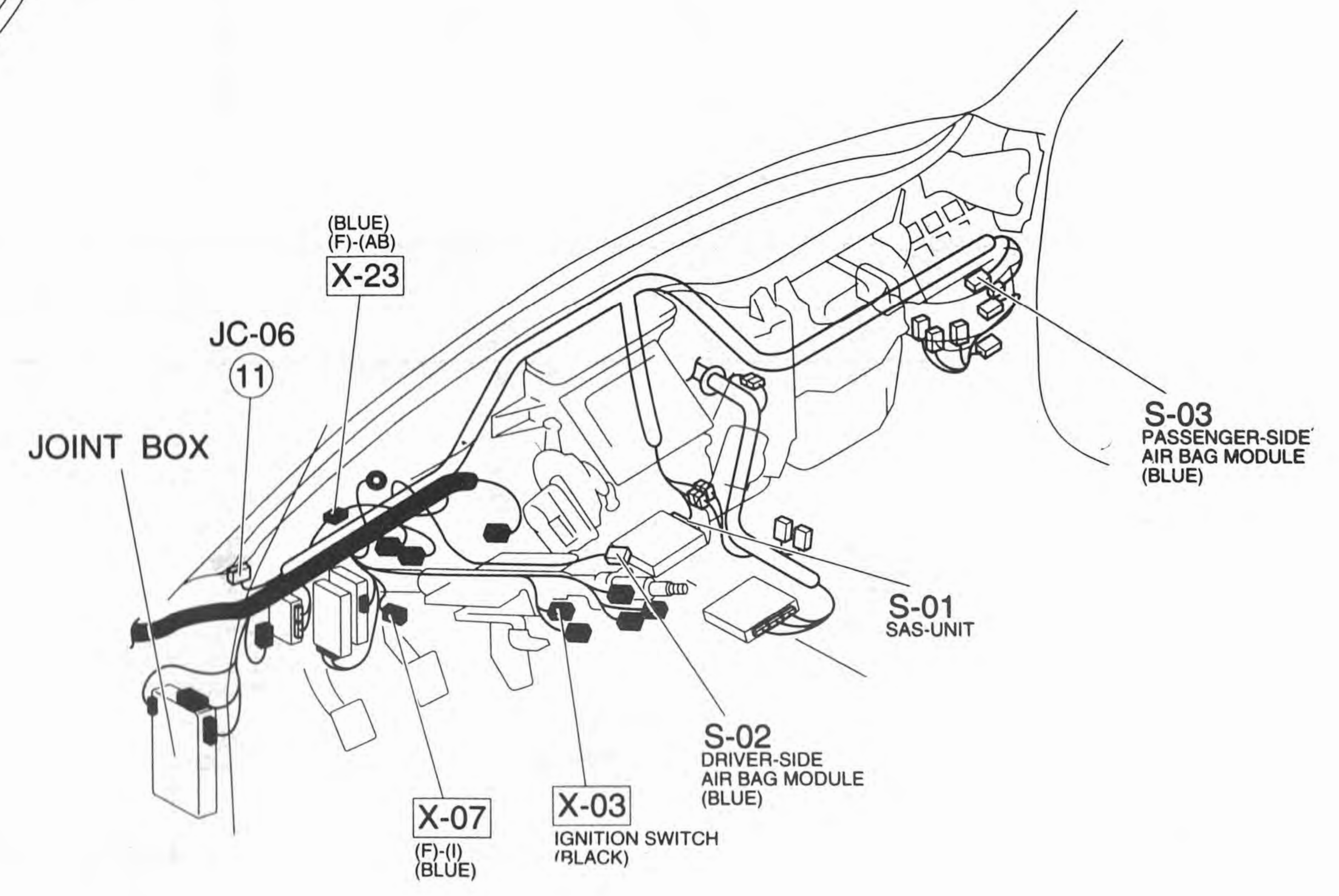
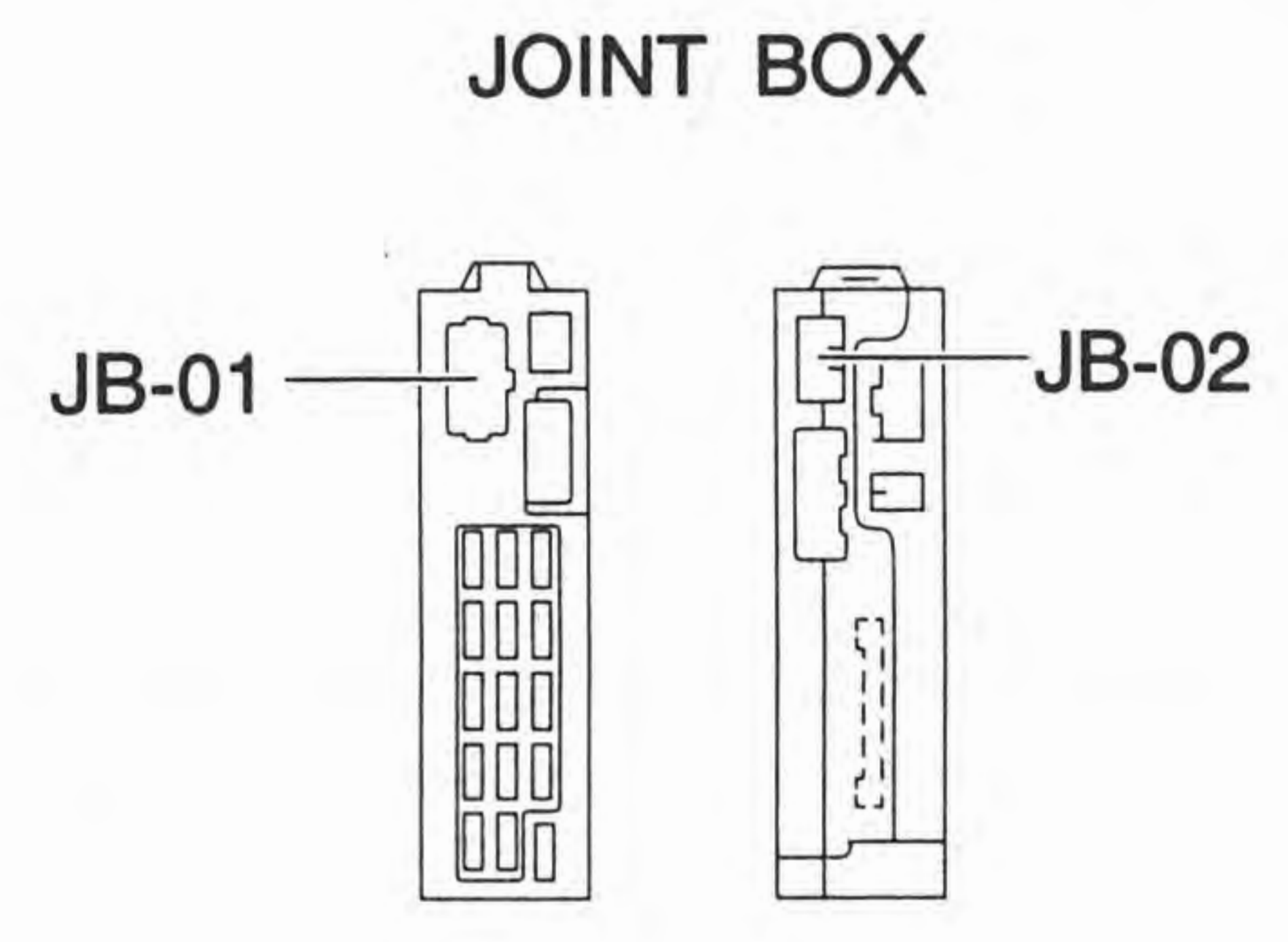
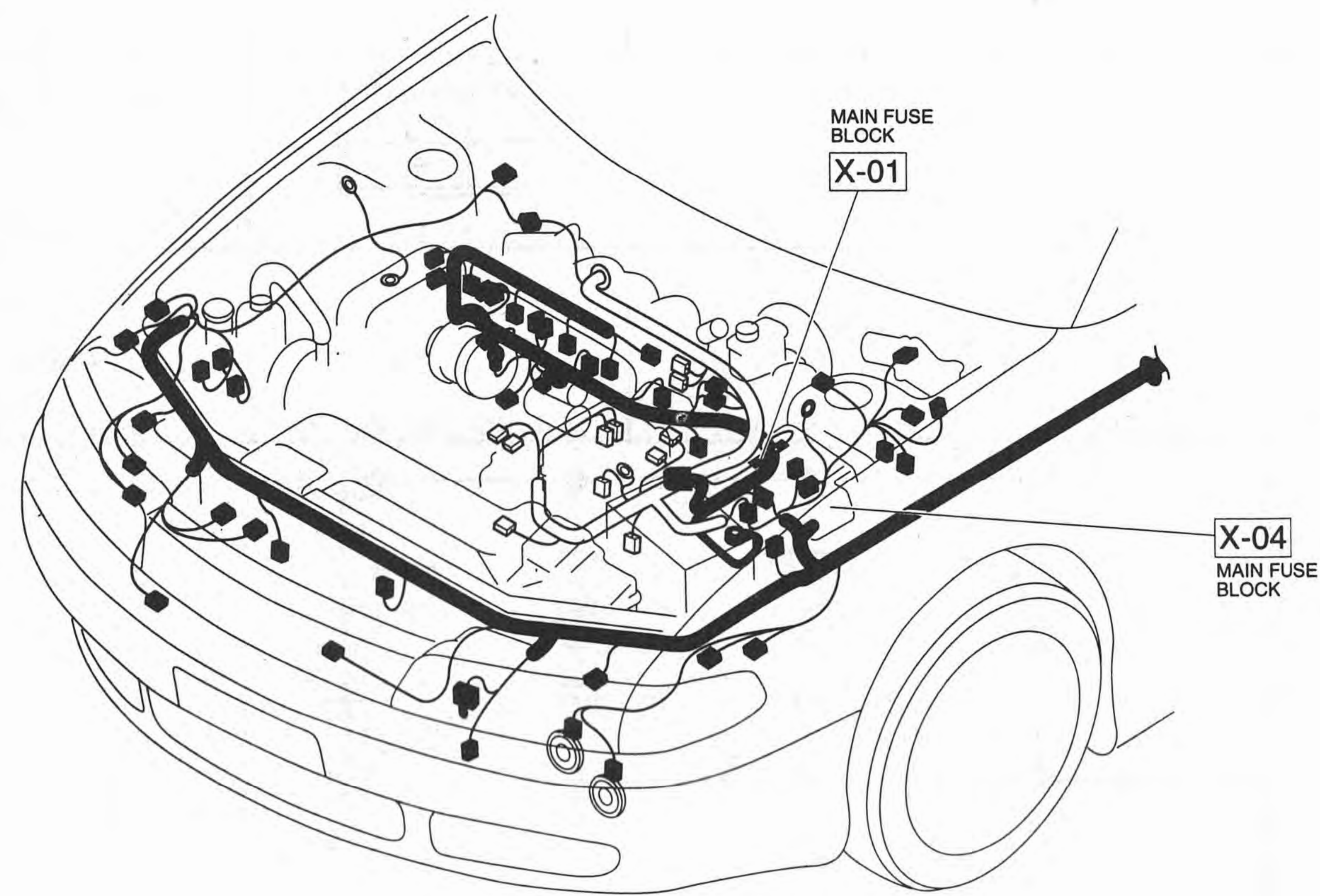

Z WIRING DIAGRAM

**T-a ■ CENTRAL PROCESSING SYSTEM
■ THEFT-DETERRENT SYSTEM**

THE CPU CONSIST OF T-a, T-b, K-5, K-6
■ . . . WITH KEYLESS ENTRY SYSTEM

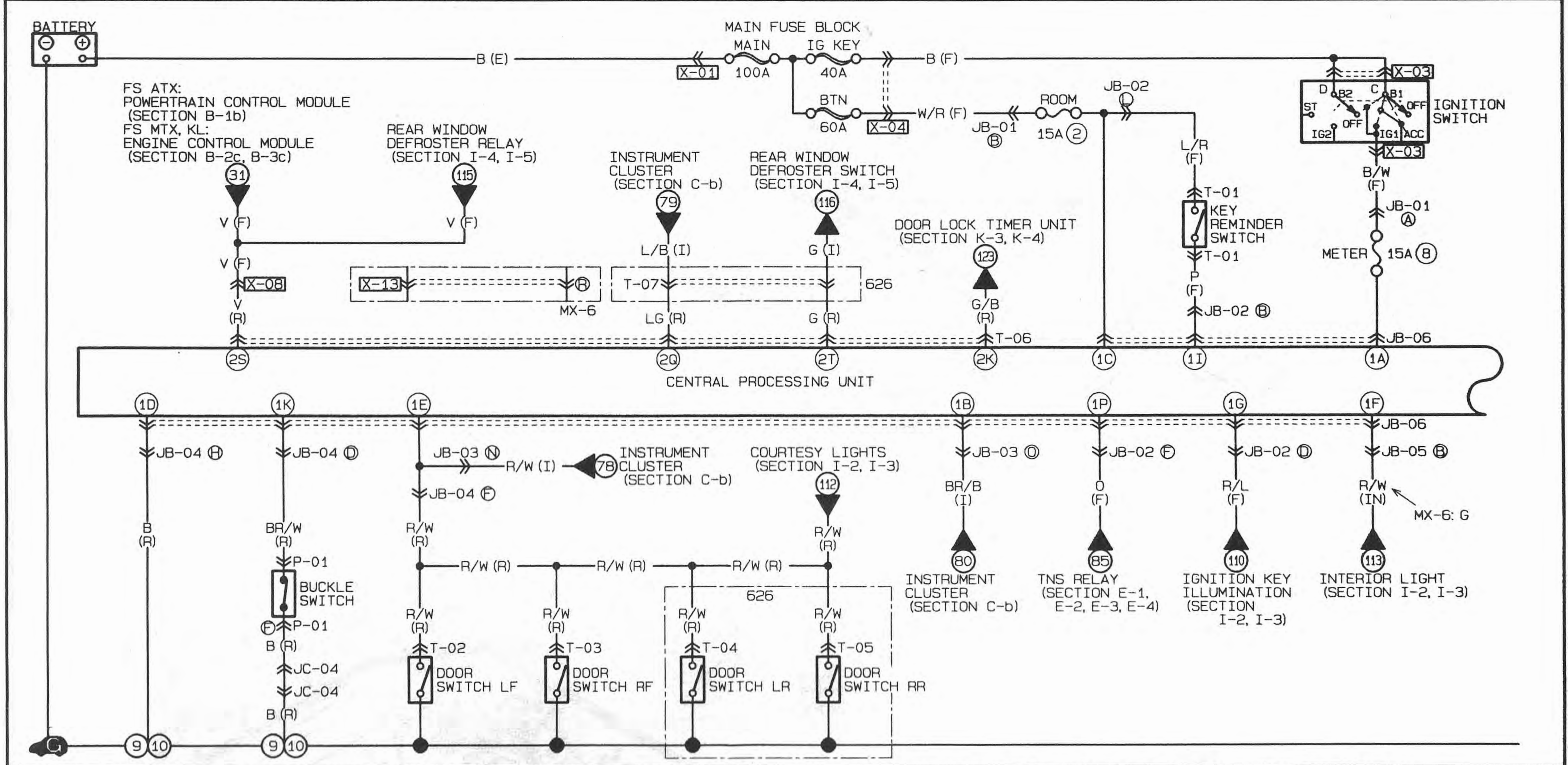

<p>T-01 KEY REMINDER SWITCH (F)</p>	<p>T-02 DOOR SWITCH LF (R)</p>	<p>T-03 DOOR SWITCH RF (R)</p>	<p>T-04 DOOR SWITCH LR (R)</p>	<p>T-05 DOOR SWITCH RR (R)</p>	<p>T-06 CENTRAL PROCESSING UNIT (R)</p> <table border="1"> <tr> <td>2S</td> <td>2Q</td> <td>20</td> <td>2M</td> <td>2K</td> <td>2I</td> <td>2G</td> <td>2E</td> <td>2C</td> <td>2A</td> </tr> <tr> <td>V</td> <td>LG</td> <td>*</td> <td>G/R</td> <td>G/B</td> <td>* 0</td> <td>* Y</td> <td>* BR</td> <td>LG/Y</td> <td>G/O</td> </tr> <tr> <td>G</td> <td>* R/Y</td> <td>*</td> <td>BR/W</td> <td>BR/Y</td> <td>R</td> <td>LG/R</td> <td>Y/R</td> <td>LG</td> <td>W/R</td> </tr> <tr> <td>2T</td> <td>2R</td> <td>2P</td> <td>2N</td> <td>2L</td> <td>2J</td> <td>2H</td> <td>2F</td> <td>2D</td> <td>2B</td> </tr> </table>	2S	2Q	20	2M	2K	2I	2G	2E	2C	2A	V	LG	*	G/R	G/B	* 0	* Y	* BR	LG/Y	G/O	G	* R/Y	*	BR/W	BR/Y	R	LG/R	Y/R	LG	W/R	2T	2R	2P	2N	2L	2J	2H	2F	2D	2B
2S	2Q	20	2M	2K	2I	2G	2E	2C	2A																																				
V	LG	*	G/R	G/B	* 0	* Y	* BR	LG/Y	G/O																																				
G	* R/Y	*	BR/W	BR/Y	R	LG/R	Y/R	LG	W/R																																				
2T	2R	2P	2N	2L	2J	2H	2F	2D	2B																																				
<p>T-07 INSTRUMENT PANEL (I) - REAR (R)</p>	<p>P-01 BUCKLE SWITCH (R)</p>																																												

T-a

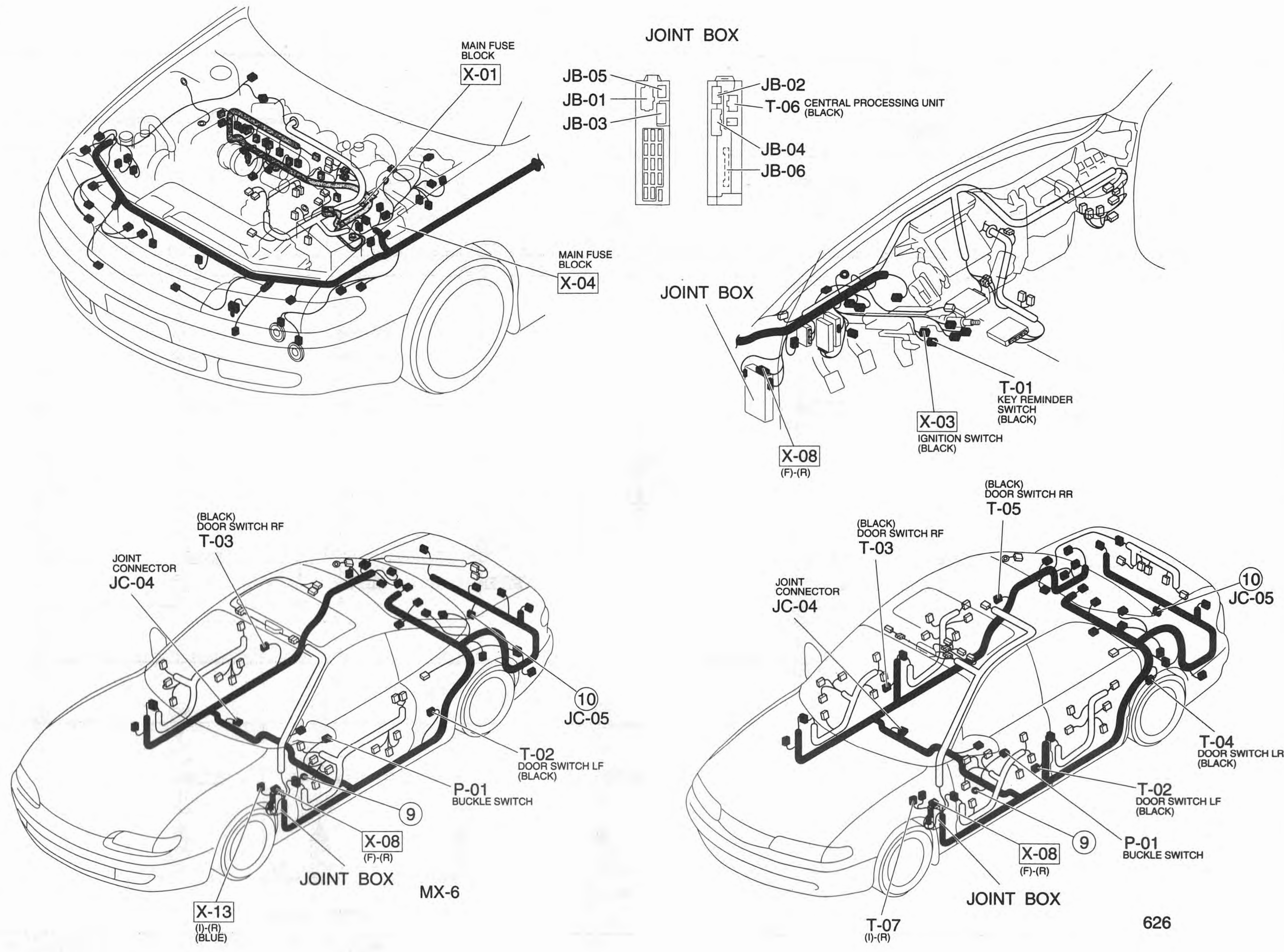

Z WIRING DIAGRAM

T-b ■ CENTRAL PROCESSING SYSTEM
■ THEFT-DETERRENT SYSTEM

THE CPU CONSIST OF T-a, T-b, K-5, K-6
 ■...WITH KEYLESS ENTRY SYSTEM

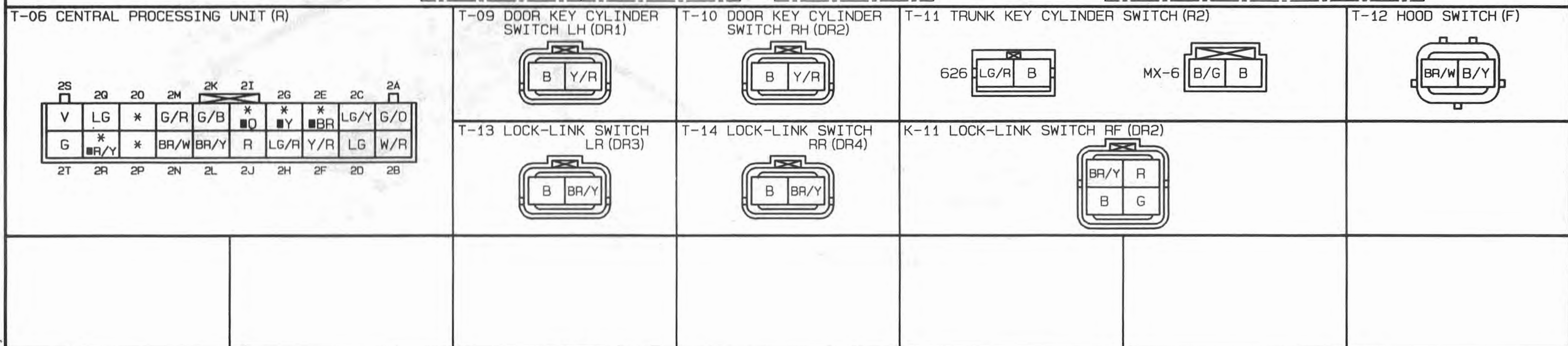
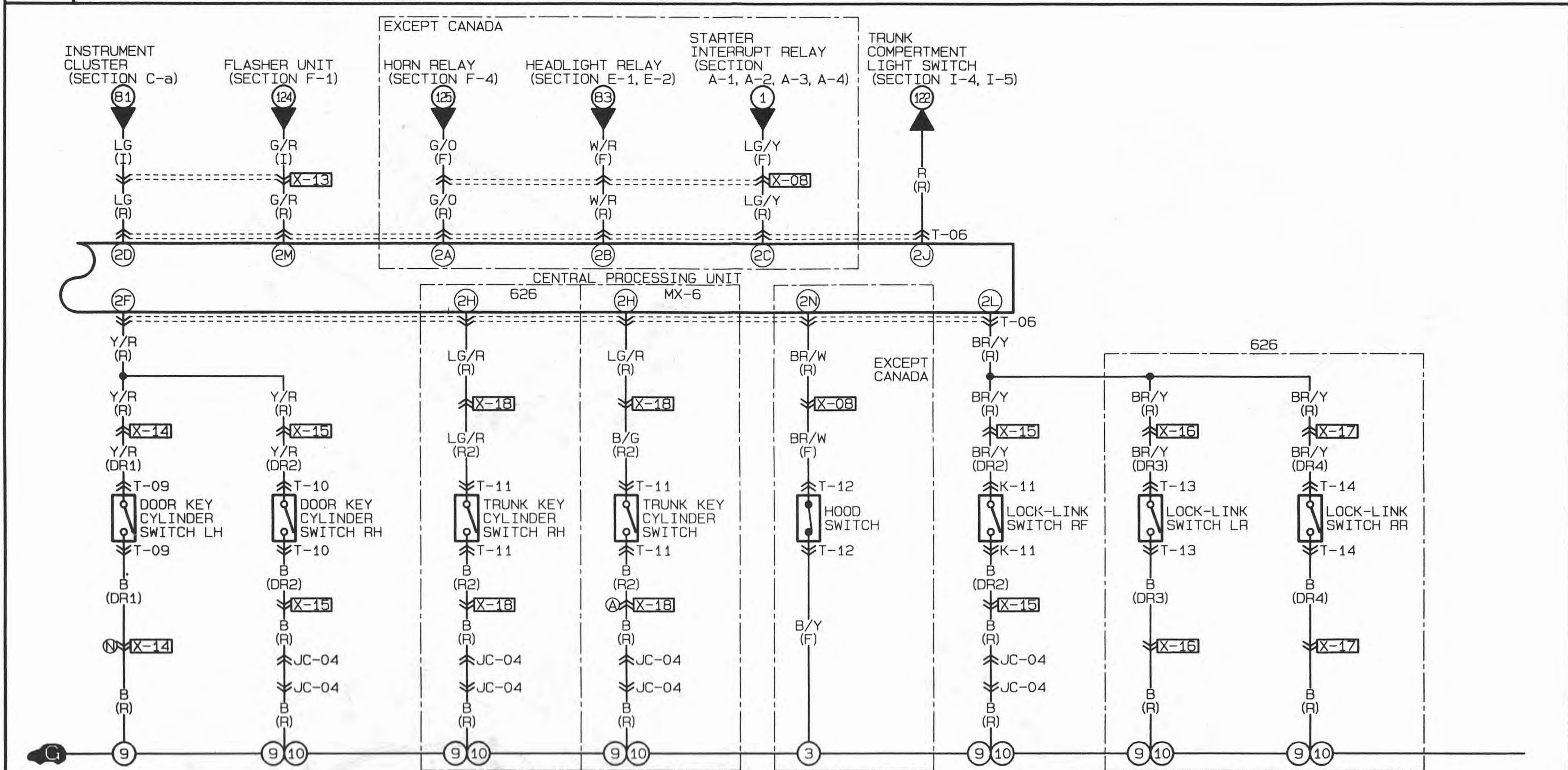

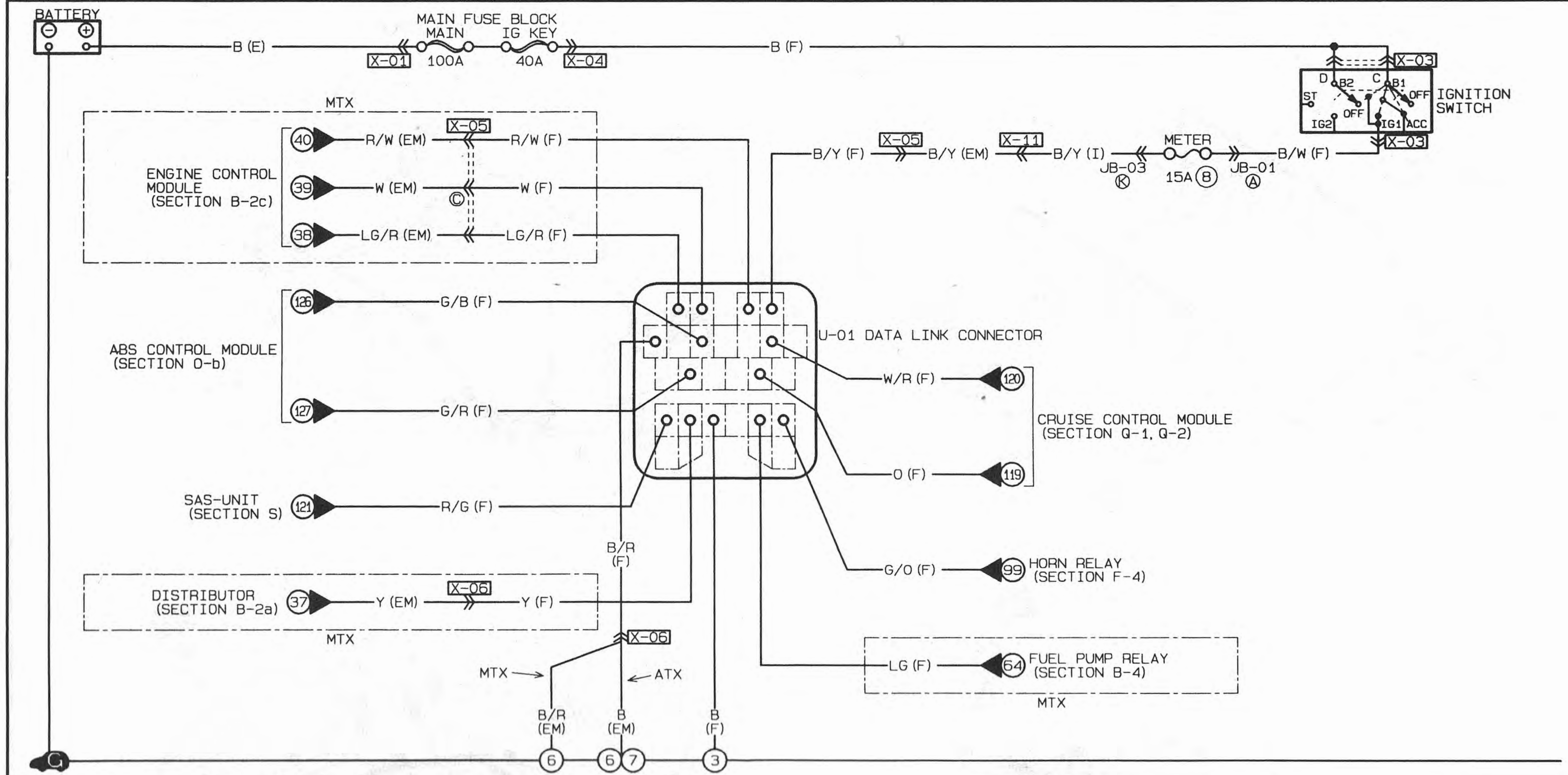

U-01 DATA LINK CONNECTOR (F)

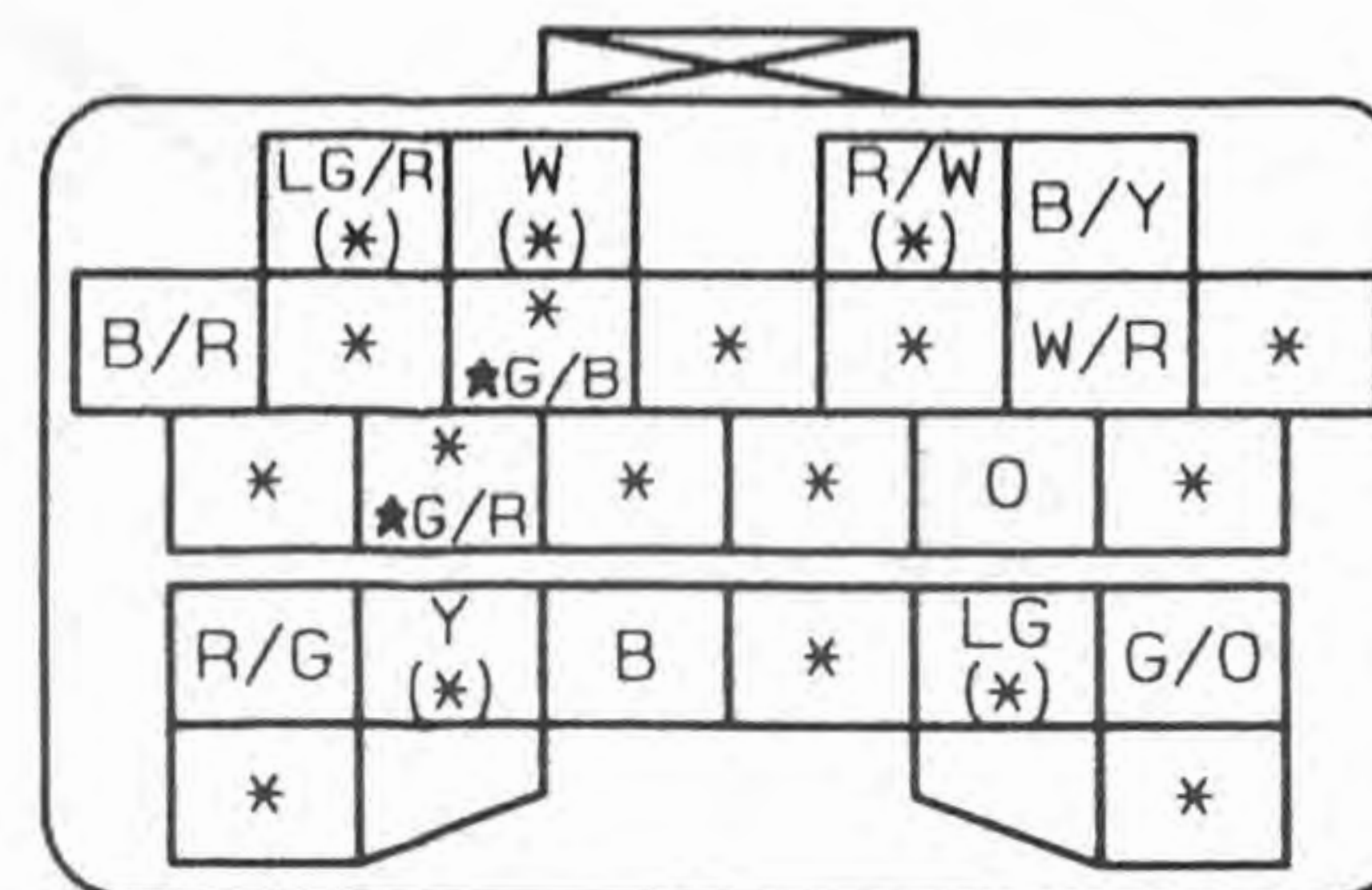
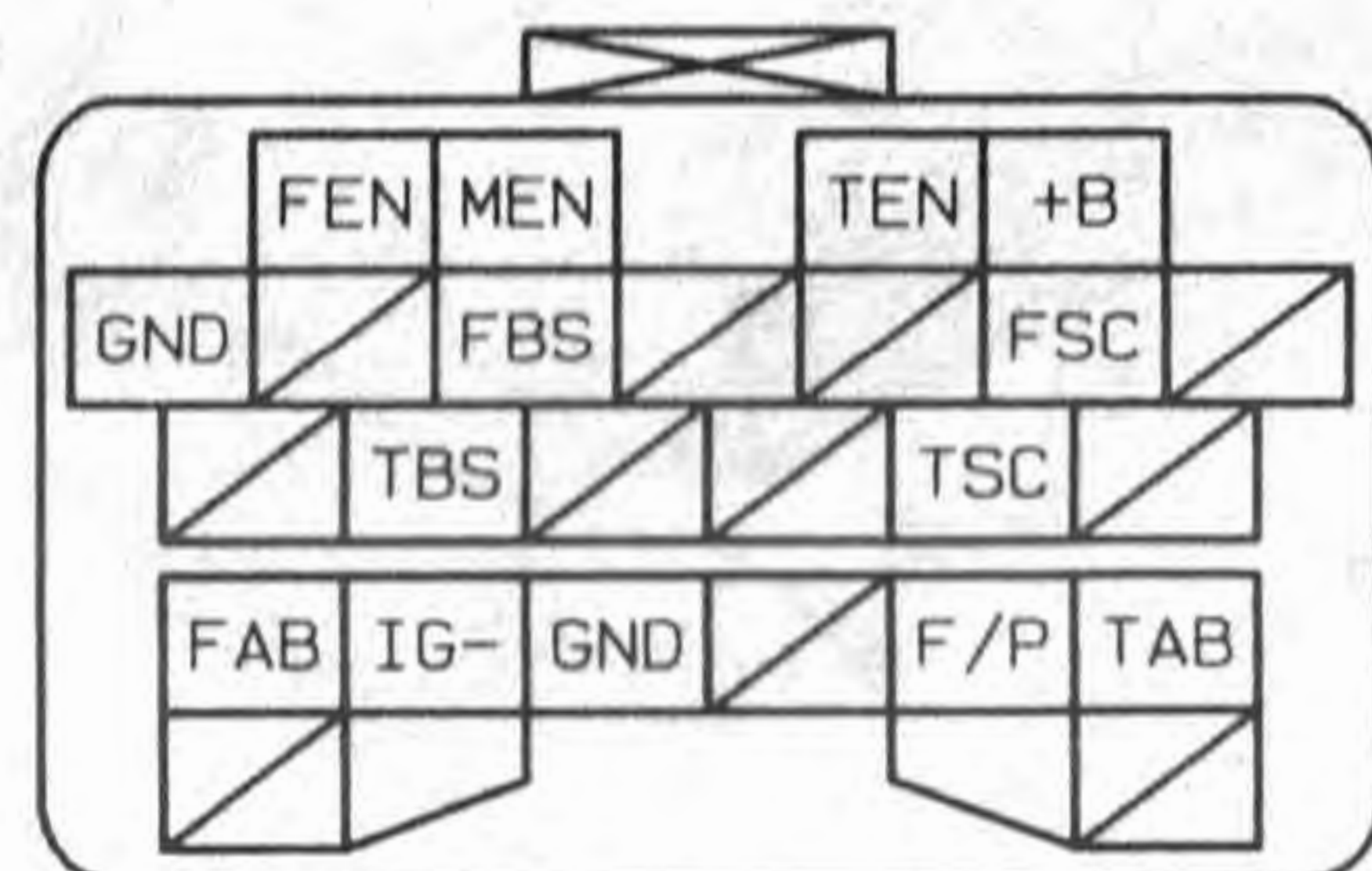

NOTE: THIS IS THE CONNECTOR AS SEEN FROM THE TERMINAL SIDE.

U-1

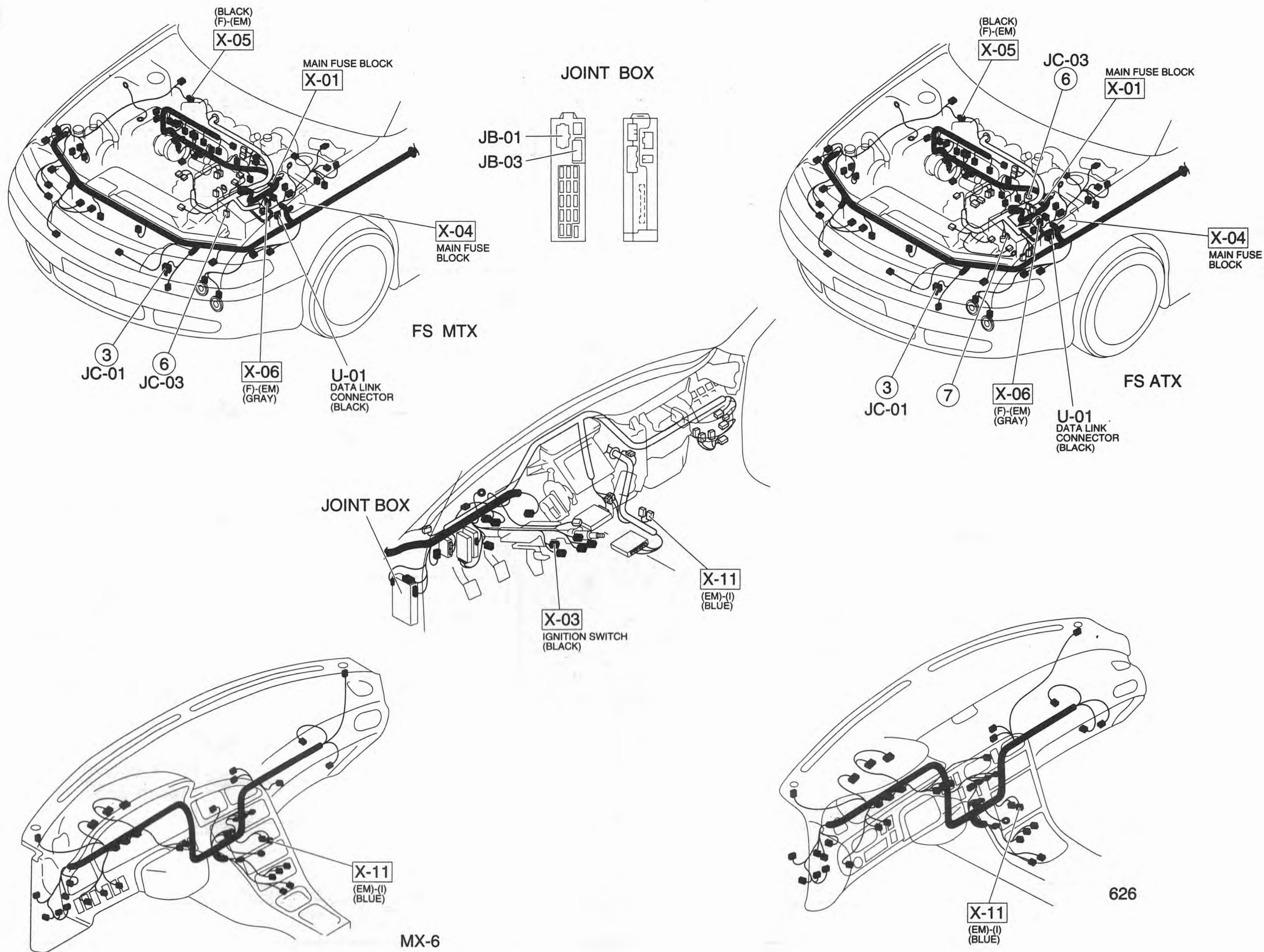

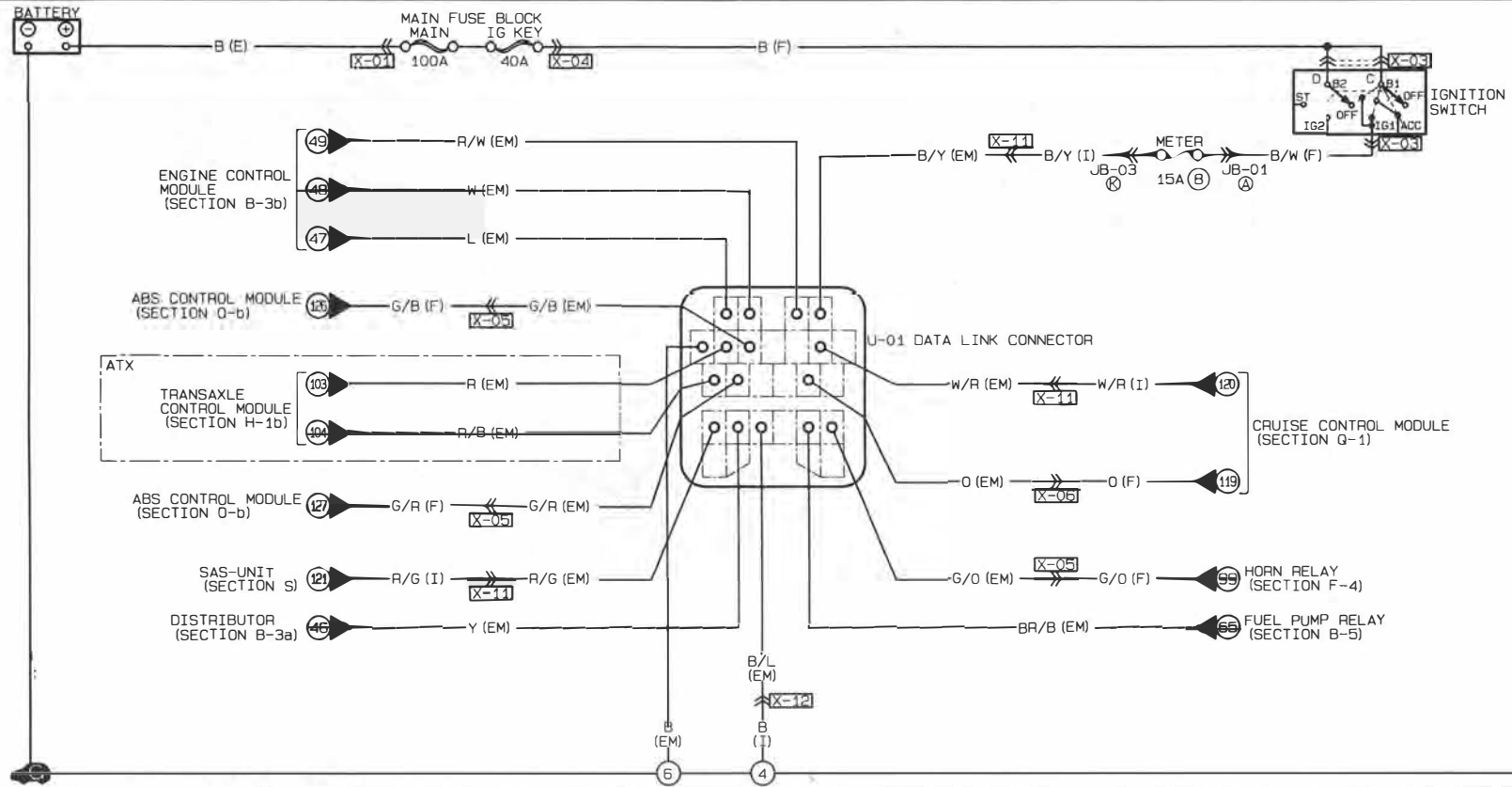

U-01 DATA LINK CONNECTOR (EM)

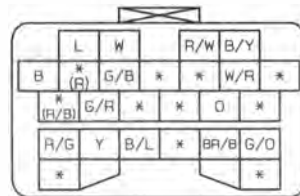
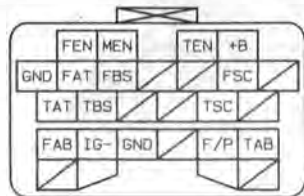

NOTE: THIS IS THE CONNECTOR AS SEEN FROM THE TERMINAL SIDE.

U-2

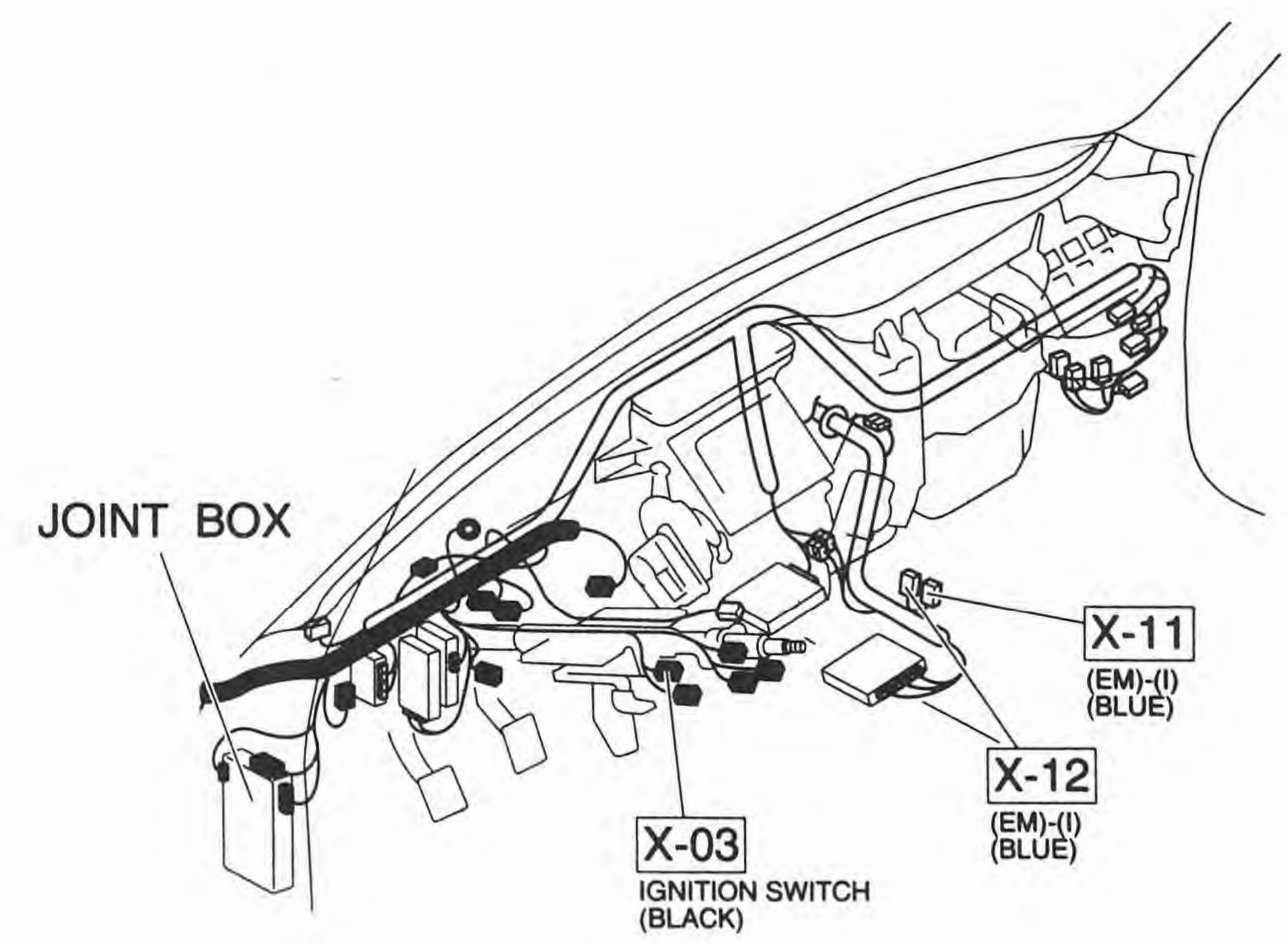
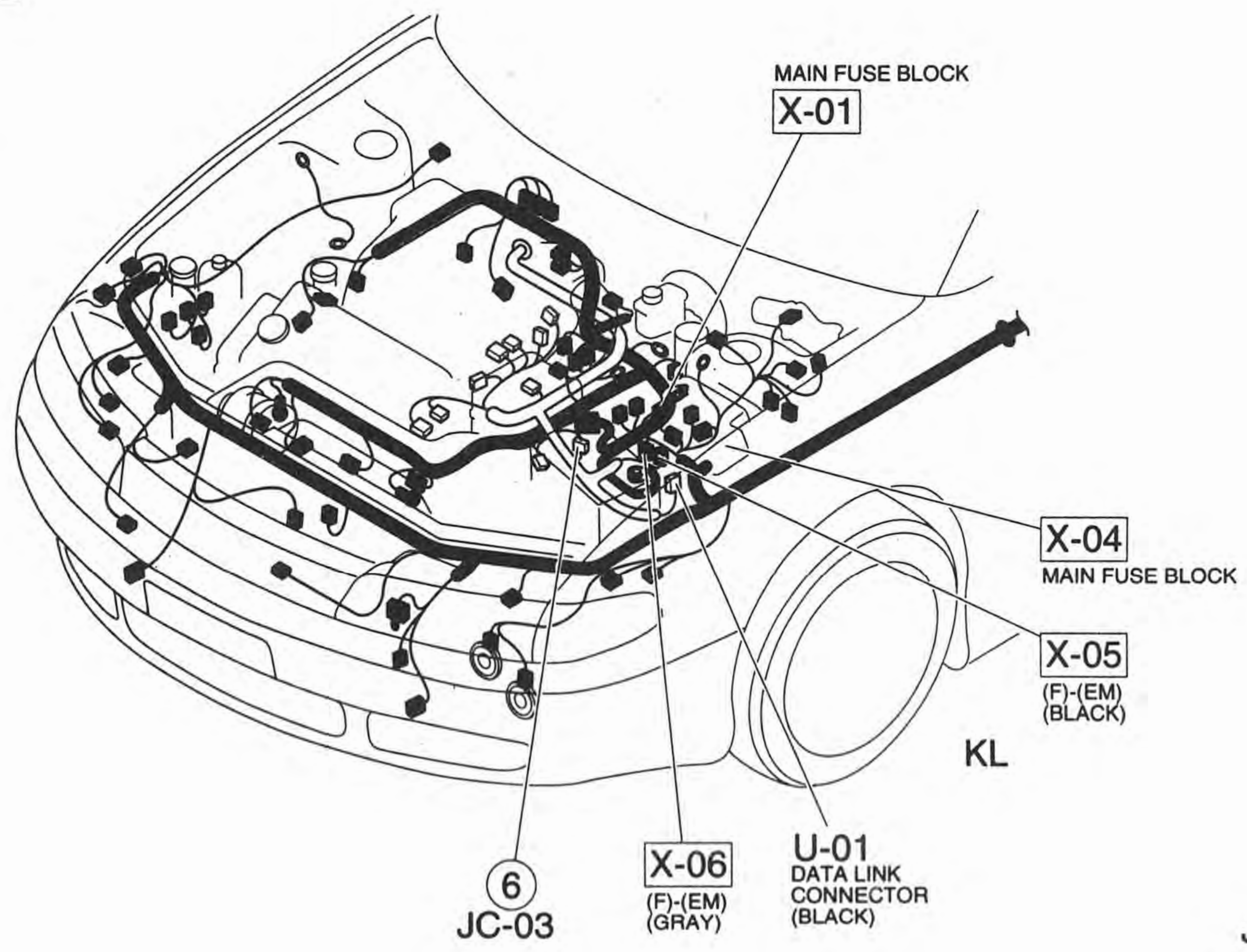

JOINT BOX

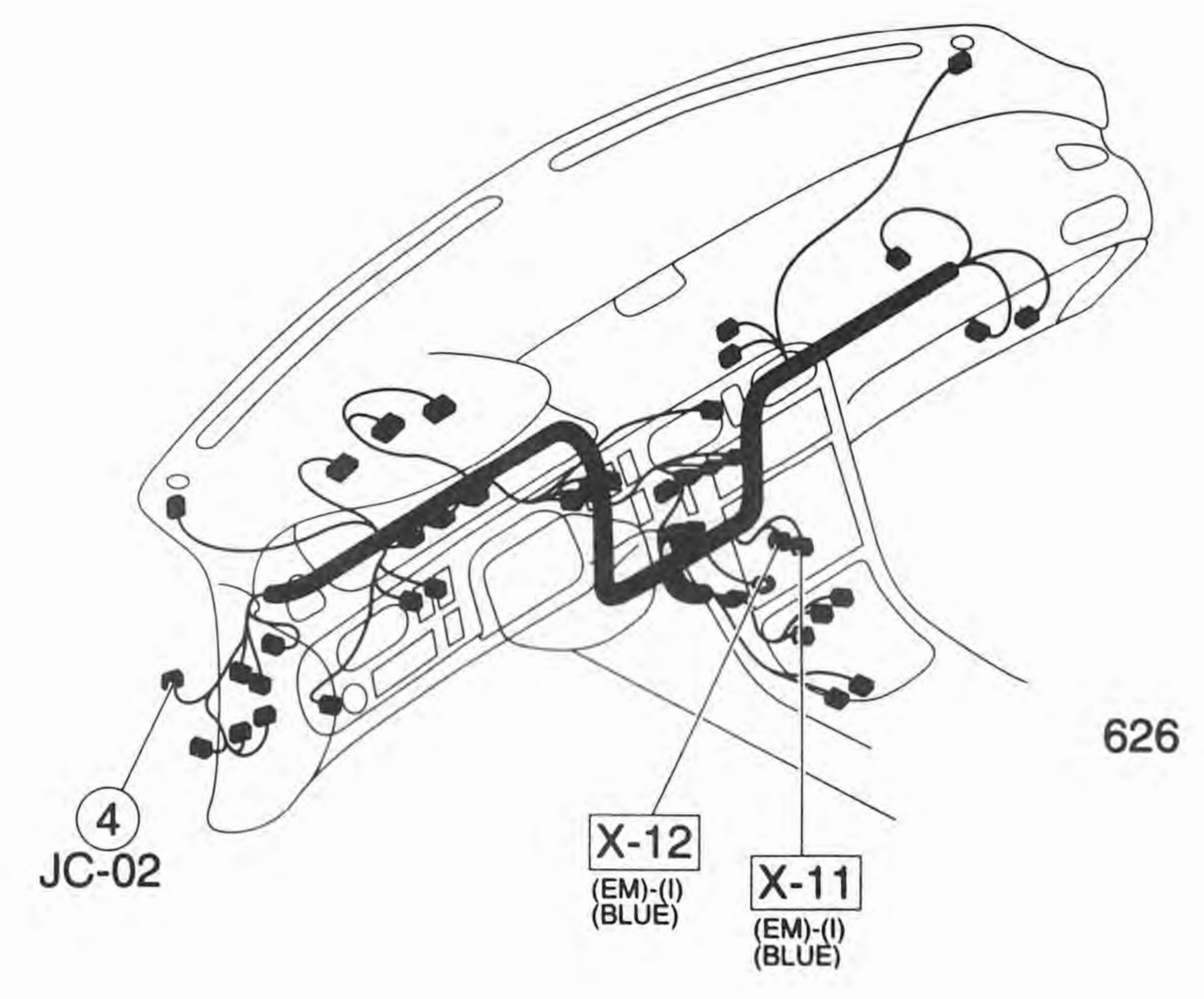
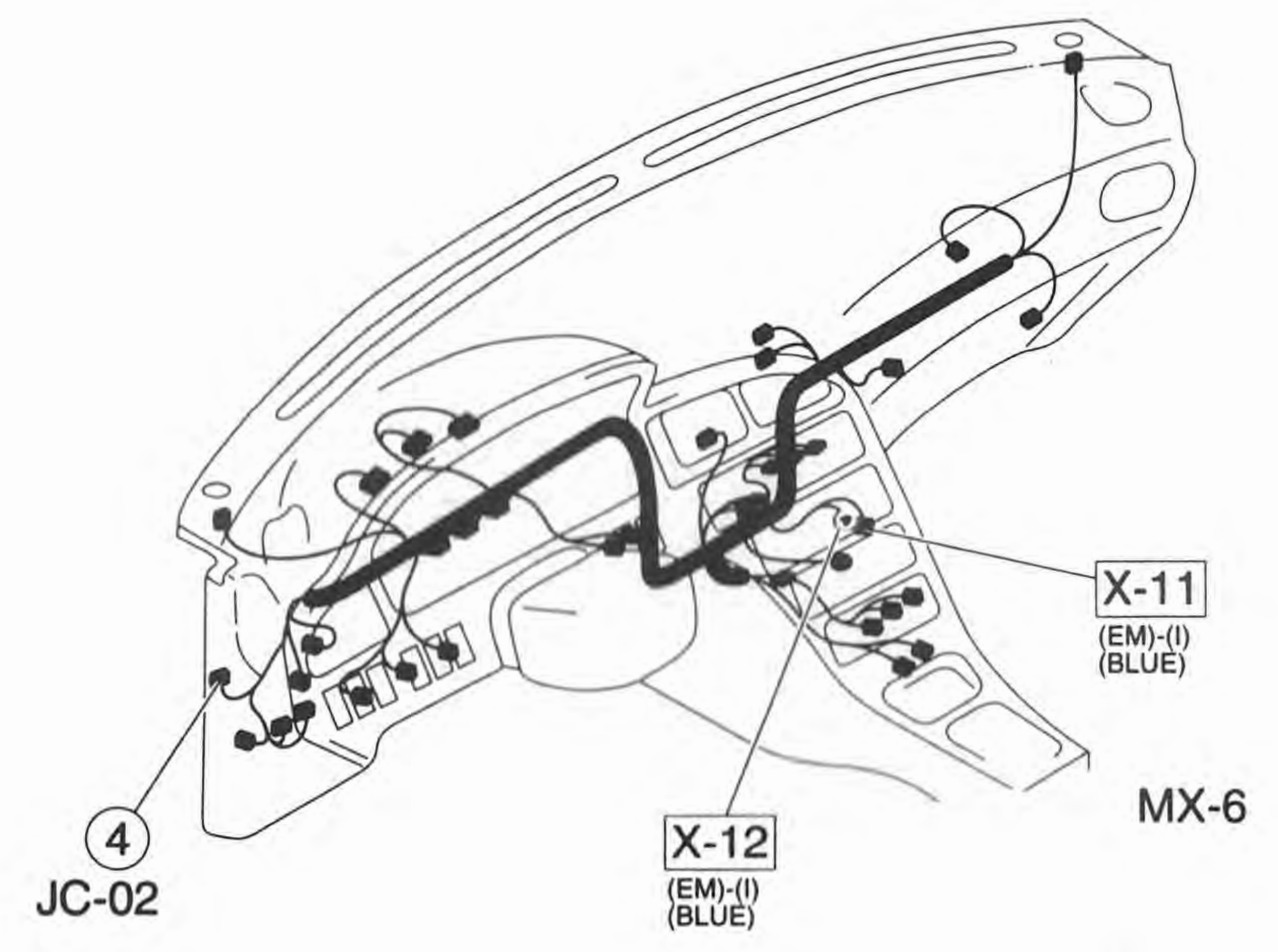
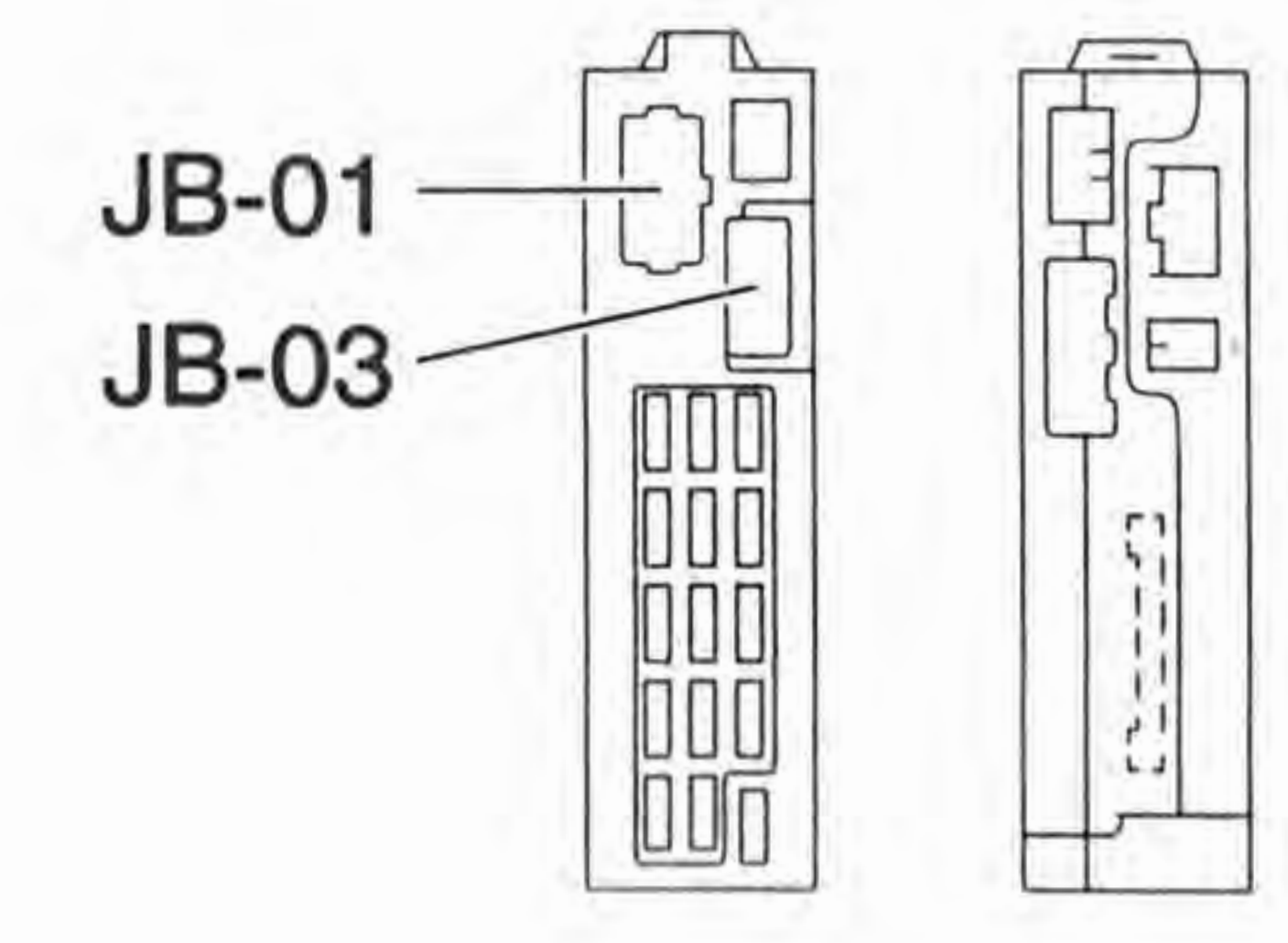

X

Z-172

() ... ATX * ... CANADA
 ● ... WITH FRONT FOG LIGHTS

X-1 ■ COMMON CONNECTOR LIST

X-01 MAIN FUSE BLOCK (E)

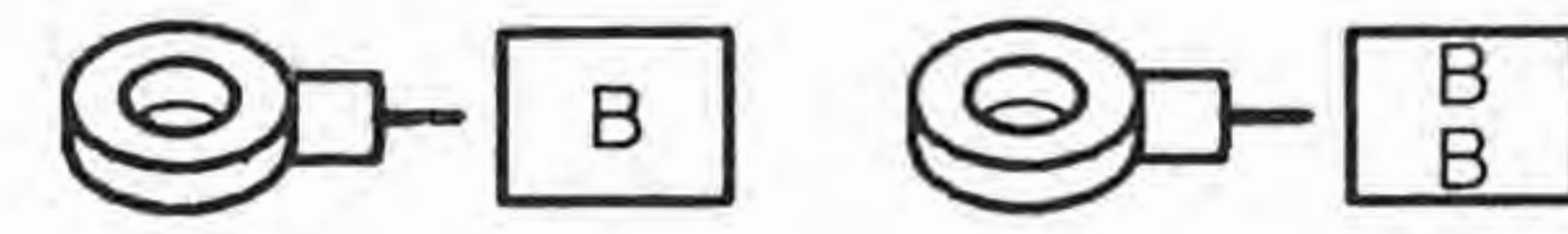

X-02 FRONT (F) -ENGINE (E)

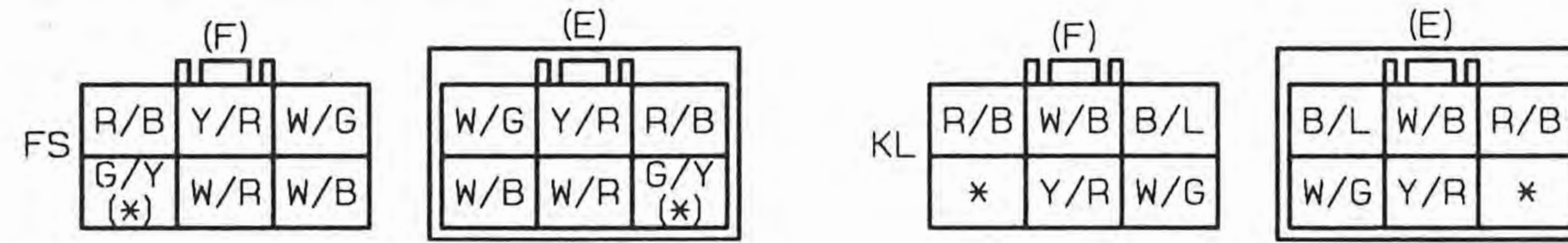

X-03 IGNITION SWITCH (F)

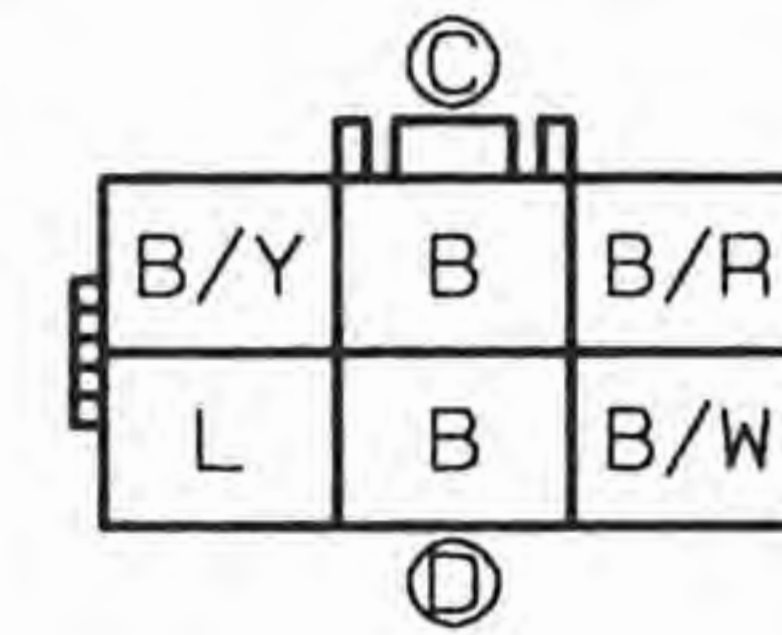

X-04 MAIN FUSE BLOCK (F)

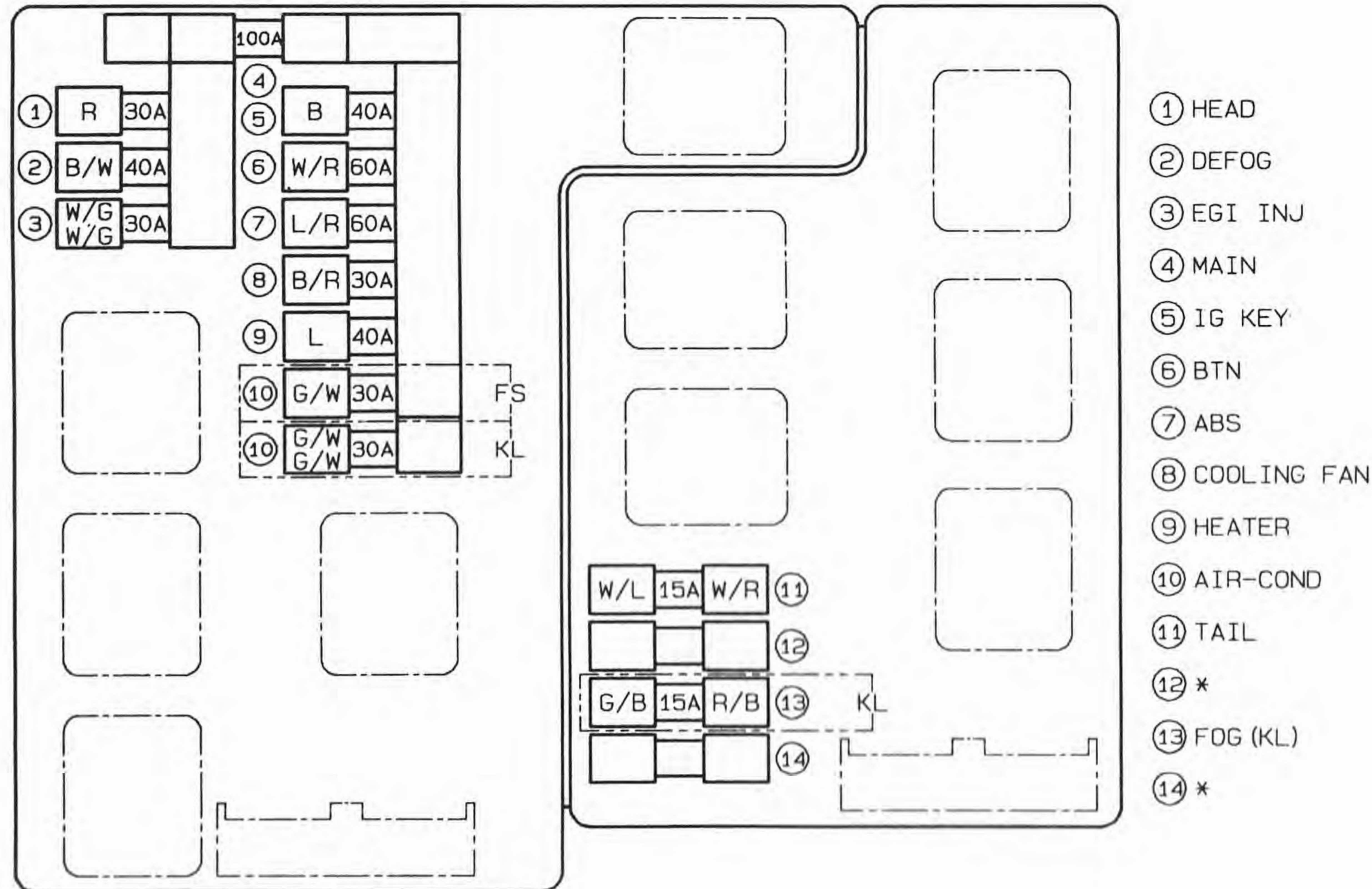

X-05 FRONT (F) -EMISSION (EM)

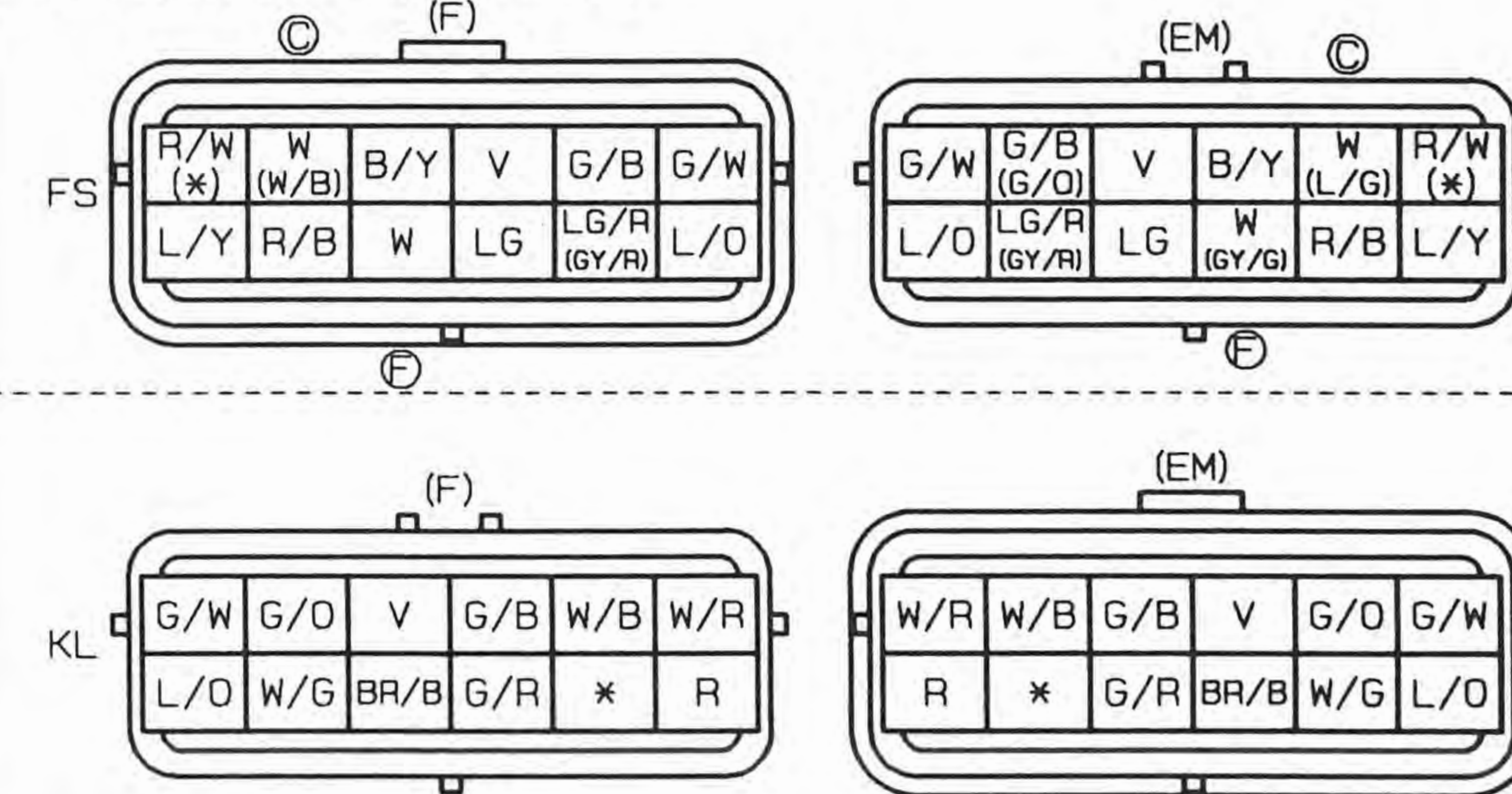

X-06 FRONT (F) -EMISSION (EM)

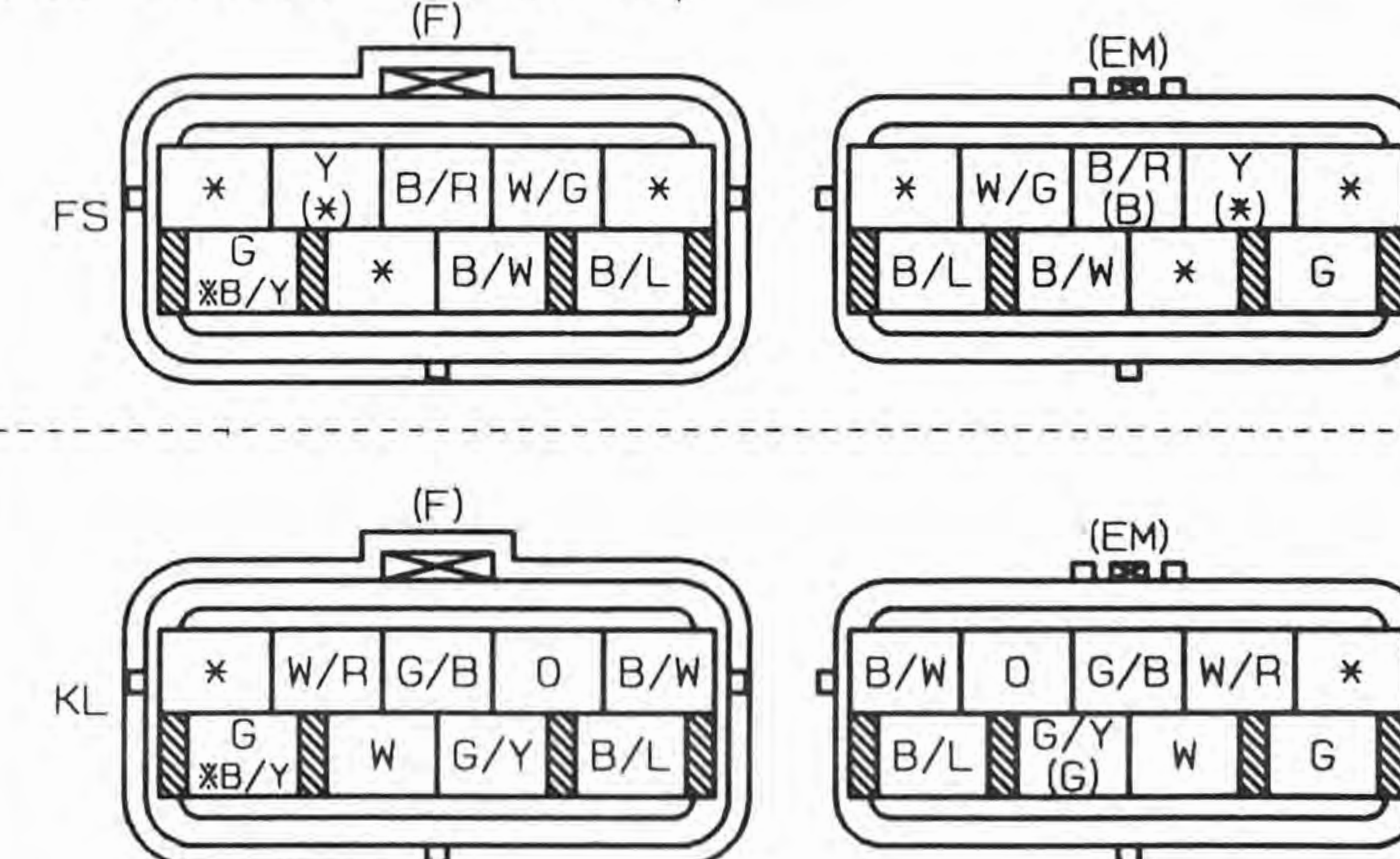

X-07 FRONT (F) -INSYRUMENT PANEL (I)

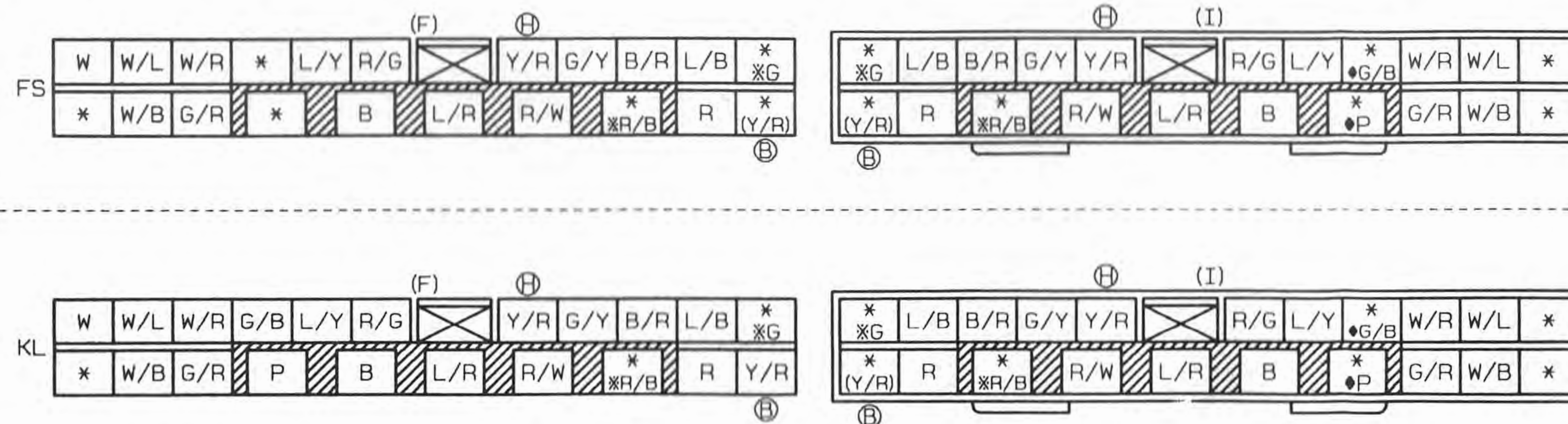



○ ... ATX ✖ ... CANADA
 ● ... MX-6 ○ ... FS ATX
 <> ... KL

X-2 ■ COMMON CONNECTOR LIST

X-08 FRONT (F) - REAR (R)

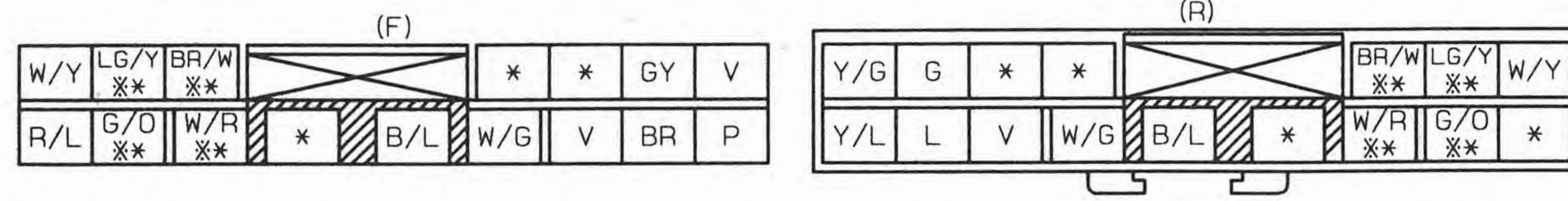

X-09 EMISSION (EM) - ENGINE (E)

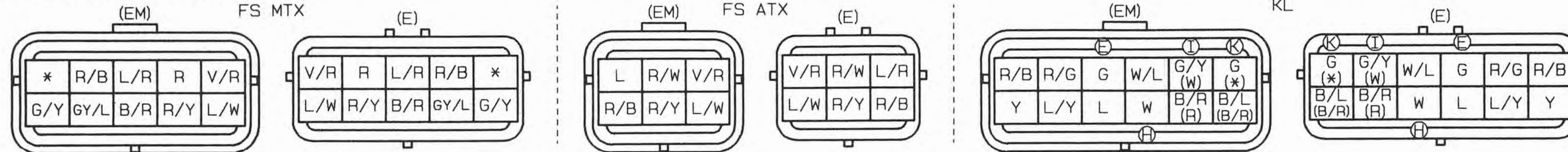

X-10 EMISSION (EM) - ENGINE (E)

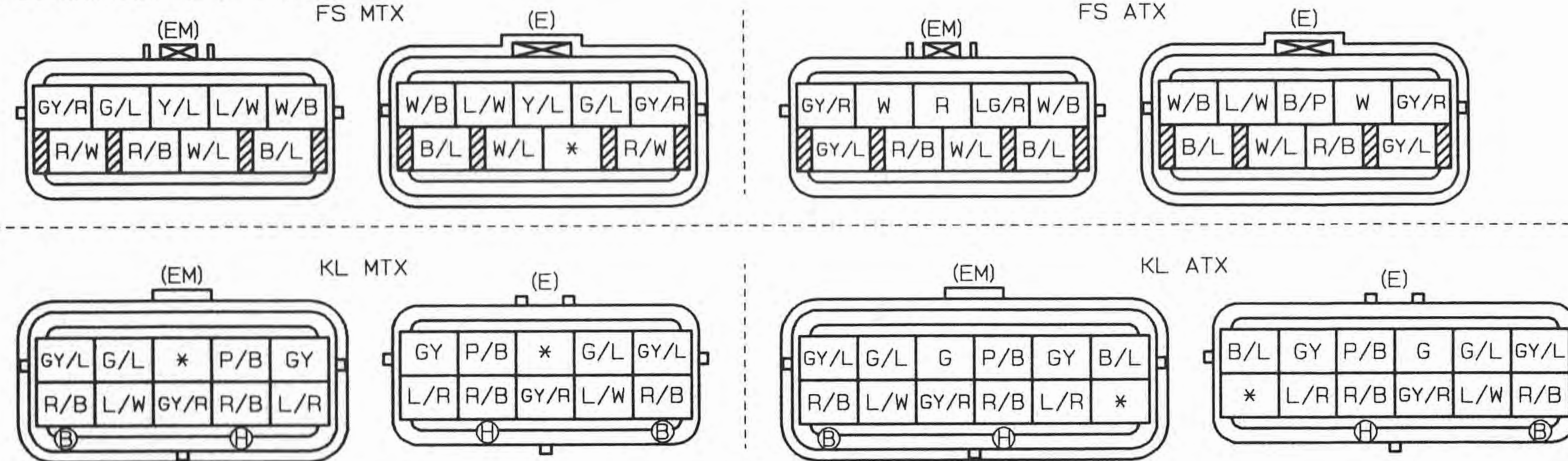

X-11 EMISSION (EM) - INSTRUMENT PANEL (I)

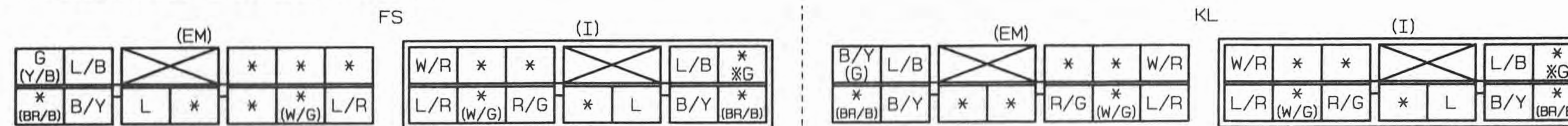

X-12 EMISSION (EM) - INSTRUMENT PANEL (I)

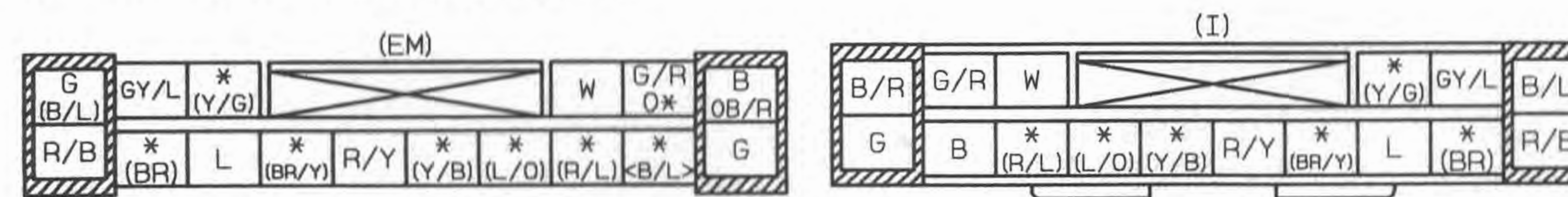

X-13 INSTRUMENT PANEL (I) - REAR (R)

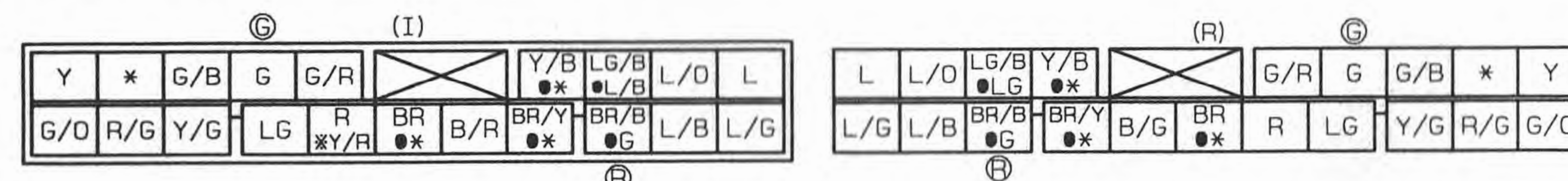



X-3 ■ COMMON CONNECTOR LIST

X-14 REAR (R) -DOOR NO. 1 (DR1)

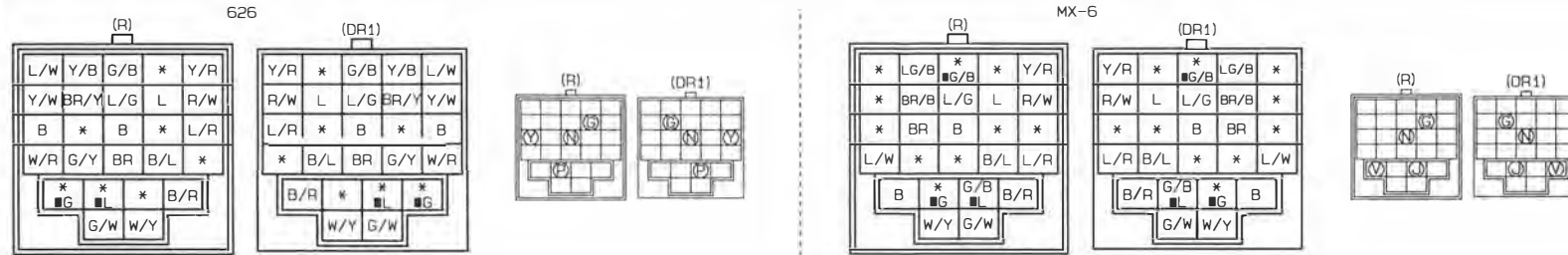

X-15 REAR (R) -DOOR NO. 2 (DR2)

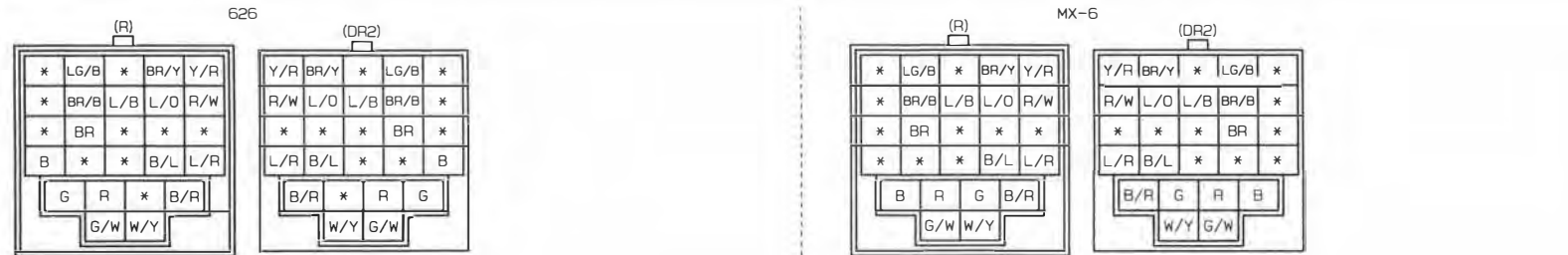

X-16 REAR (R) -DOOR NO. 3 (DR3)

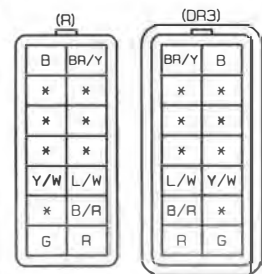

X-17 REAR (R) -DOOR NO. 4 (DR4)

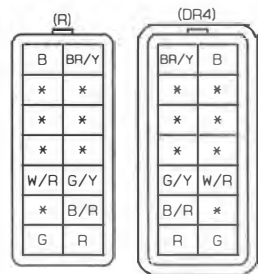

X-18 REAR (R) -REAR NO. 2 (R2)

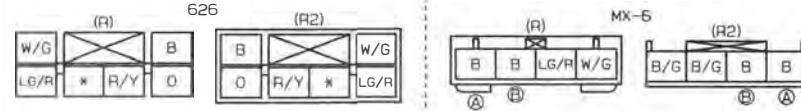

X-19 INSTRUMENT PANEL (I) -ILLUMINATION LIGHT (IL)

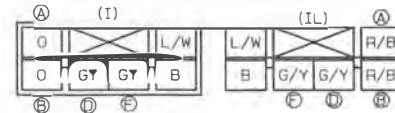

X-20 JOINT CONNECTOR (F)



X-21 JOINT CONNECTOR (F)



X-22 JOINT CONNECTOR (EM)





() ...ATX *...CANADA
 ♦...WITH FRONT FOG LIGHTS

X-4 ■ COMMON CONNECTOR LIST

X-23 FRONT (F) -AIR BAG (AB)

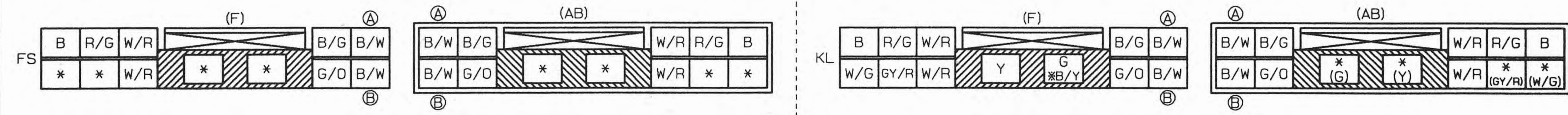

X-24 JOINT CONNECTOR (I)

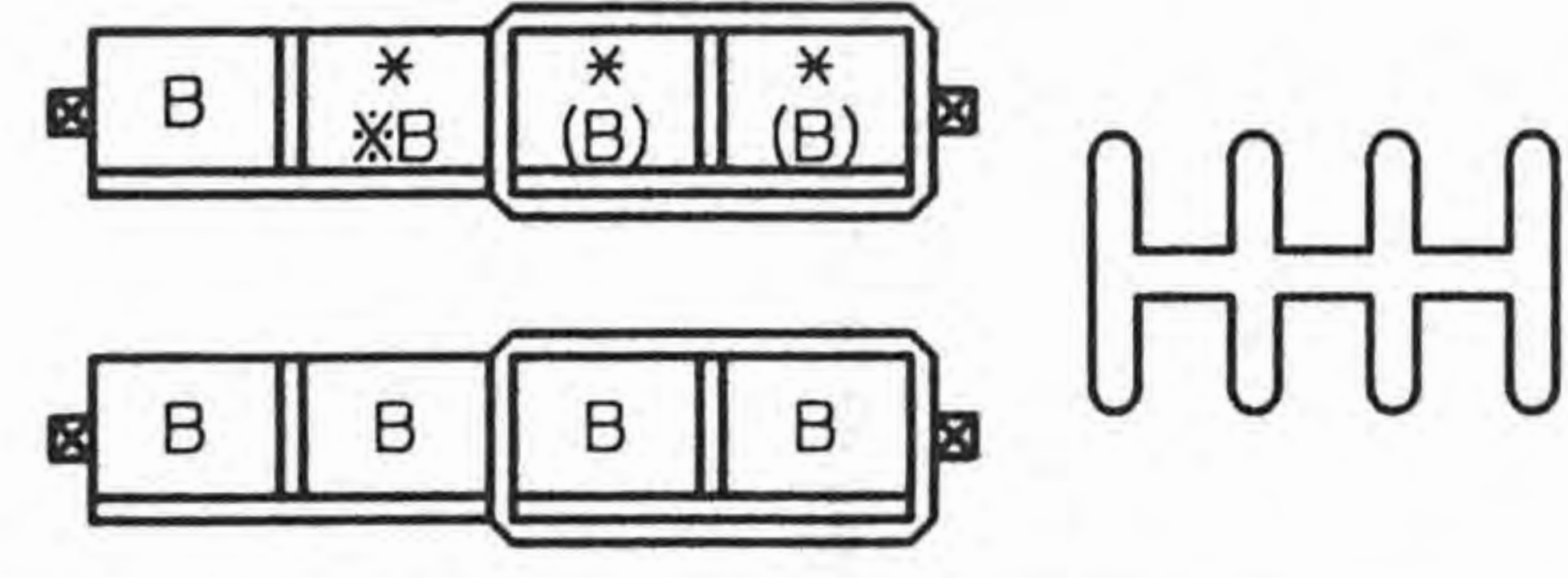

X-25 JOINT CONNECTOR (I)

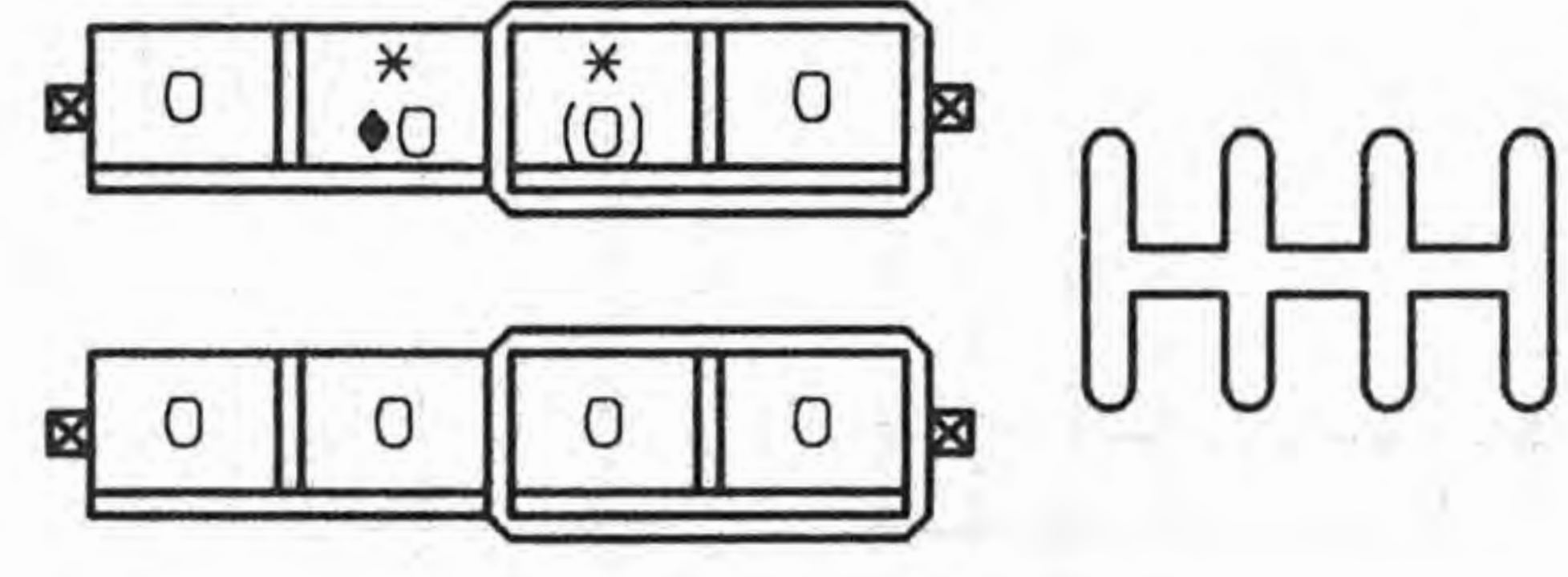

X-26 JOINT CONNECTOR (I)

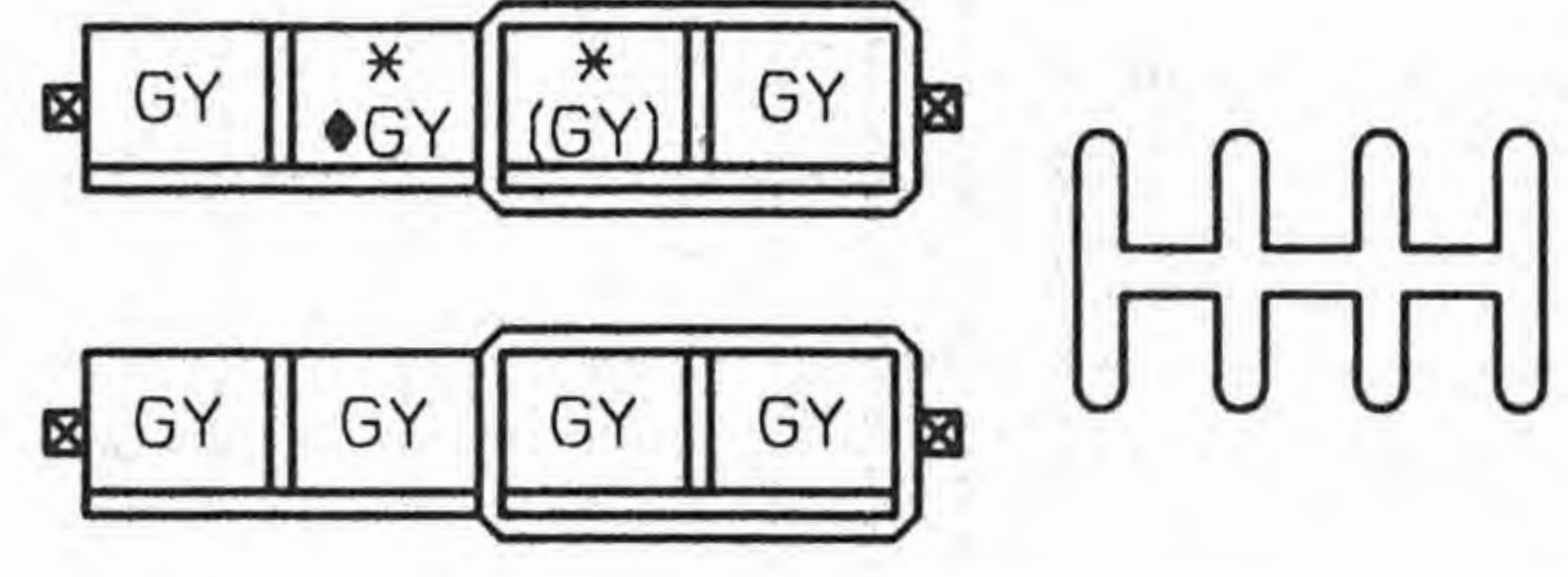

X-27 EMISSION (EM) -AIR BAG (AB)

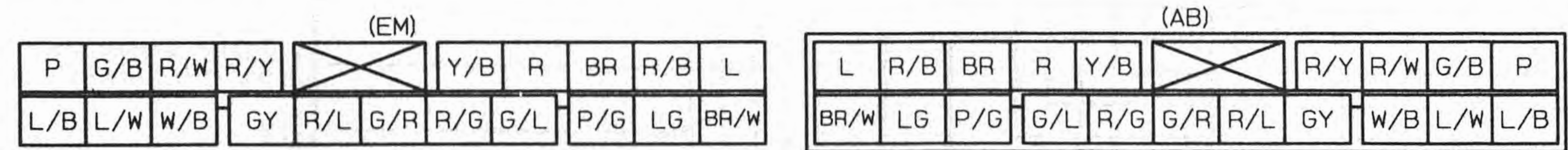

X-28 EMISSION (EM) -AIR BAG (AB)

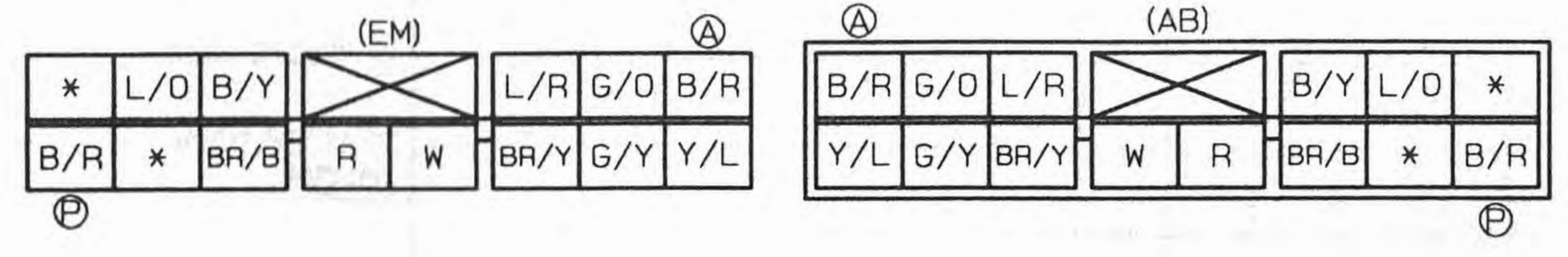

JB

JOINT BOX

Z-180

■ JOINT BOX

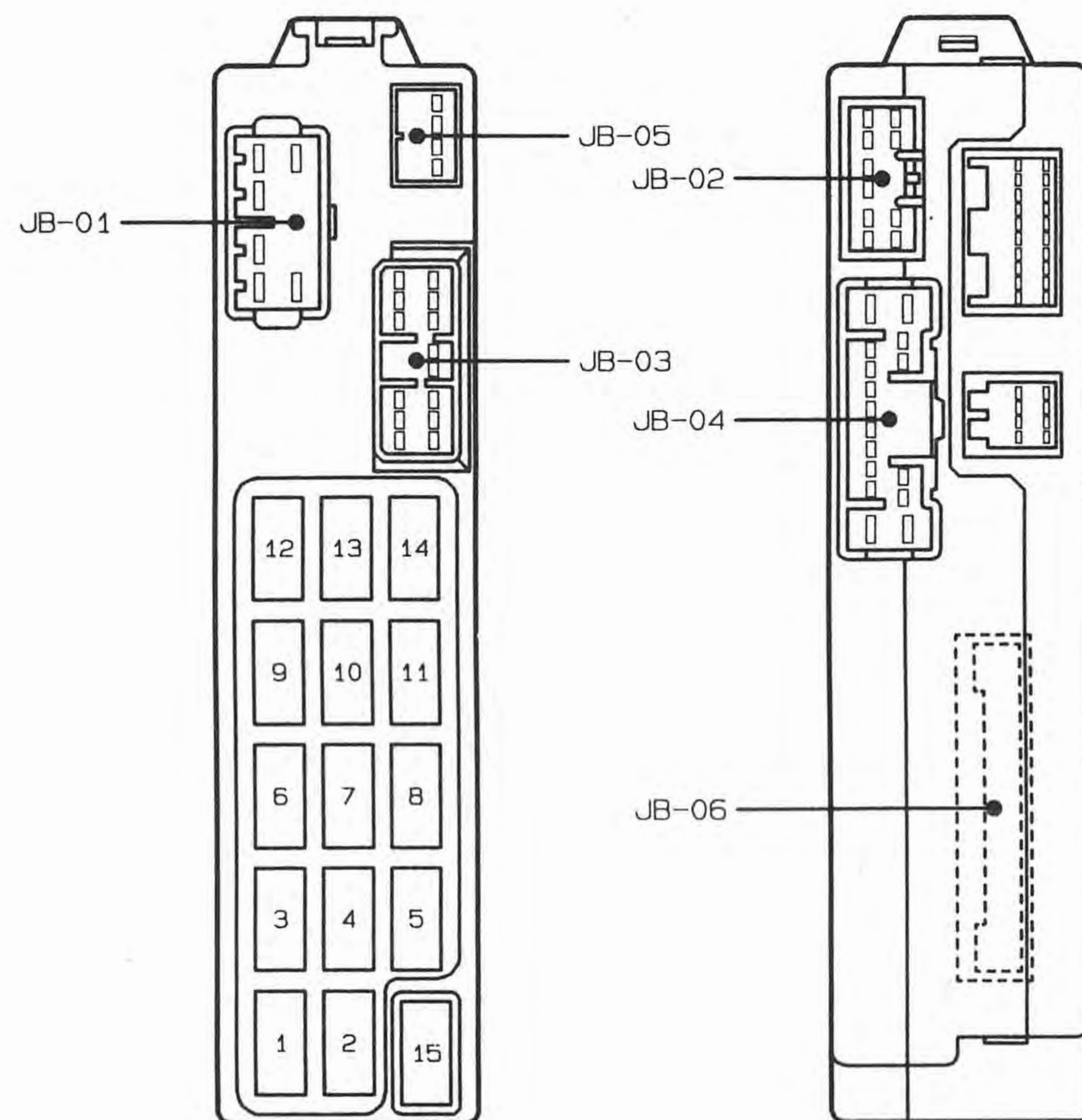

- | | | |
|---|--------------|-----|
| ① | STOP | 20A |
| ② | ROOM | 15A |
| ③ | DOOR LOCK | 30A |
| ④ | RADIO | 15A |
| ⑤ | SUNROOF | 15A |
| ⑥ | TURN | 15A |
| ⑦ | POWER SEAT | 30A |
| ⑧ | METER | 15A |
| ⑨ | HAZARD | 15A |
| ⑩ | ENGINE | 15A |
| ⑪ | POWER WINDOW | 30A |
| ⑫ | HEAD CLEANER | 20A |
| ⑬ | WIPER | 20A |
| ⑭ | REAR WIPER | 20A |
| ⑮ | SPARE | 15A |

JB-01 FRONT HARNESS (F)

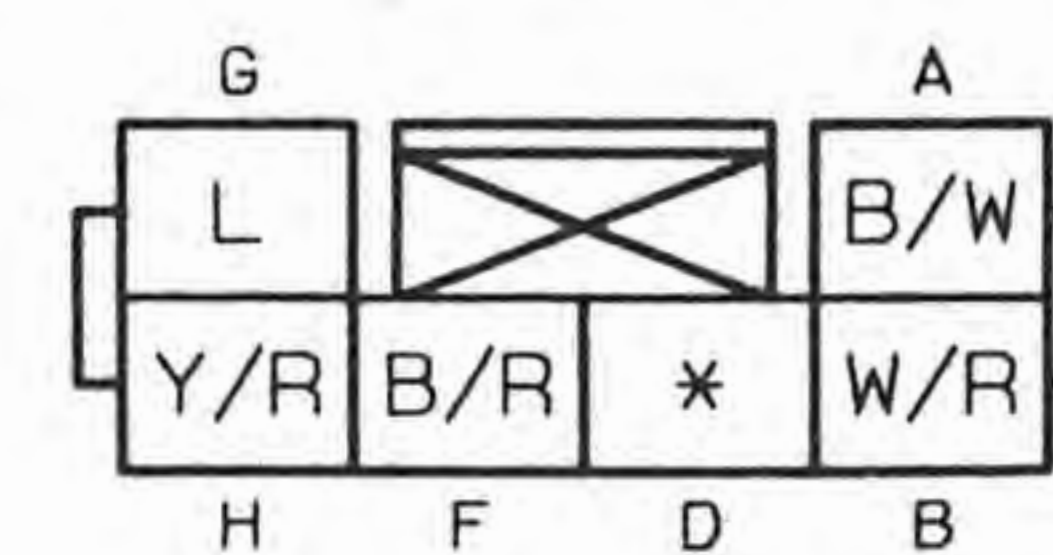

JB-02 FRONT HARNESS (F)

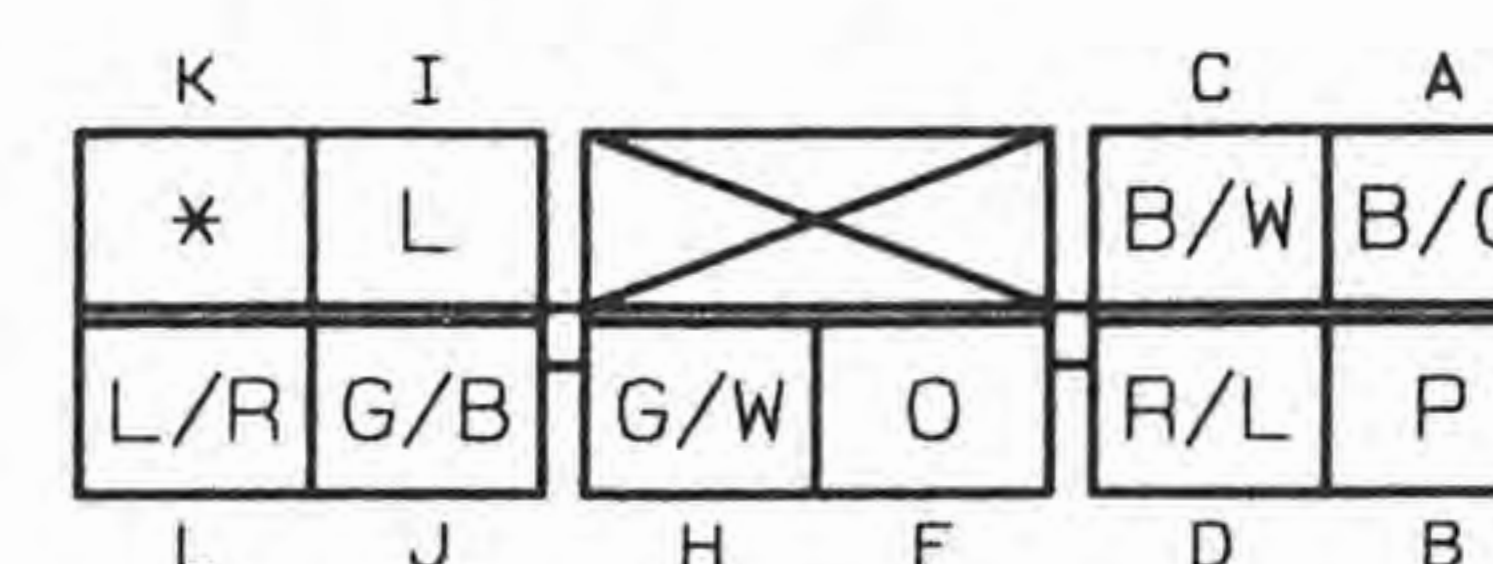

JB-03 INSTRUMENT PANEL HARNESS (I)

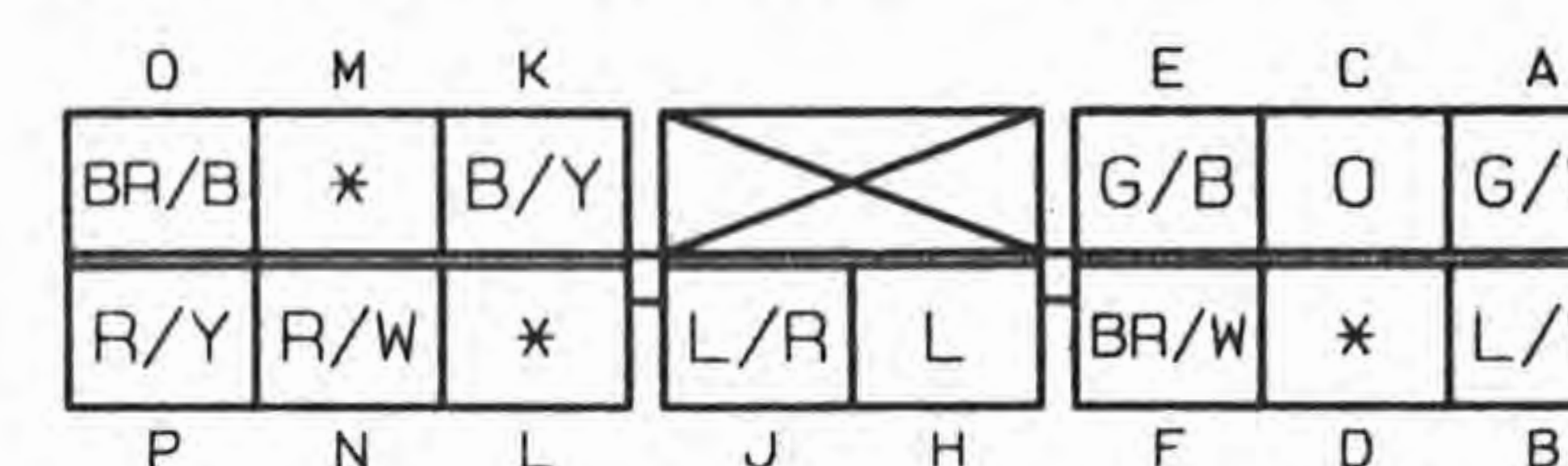

JB-04 REAR HARNESS (R)

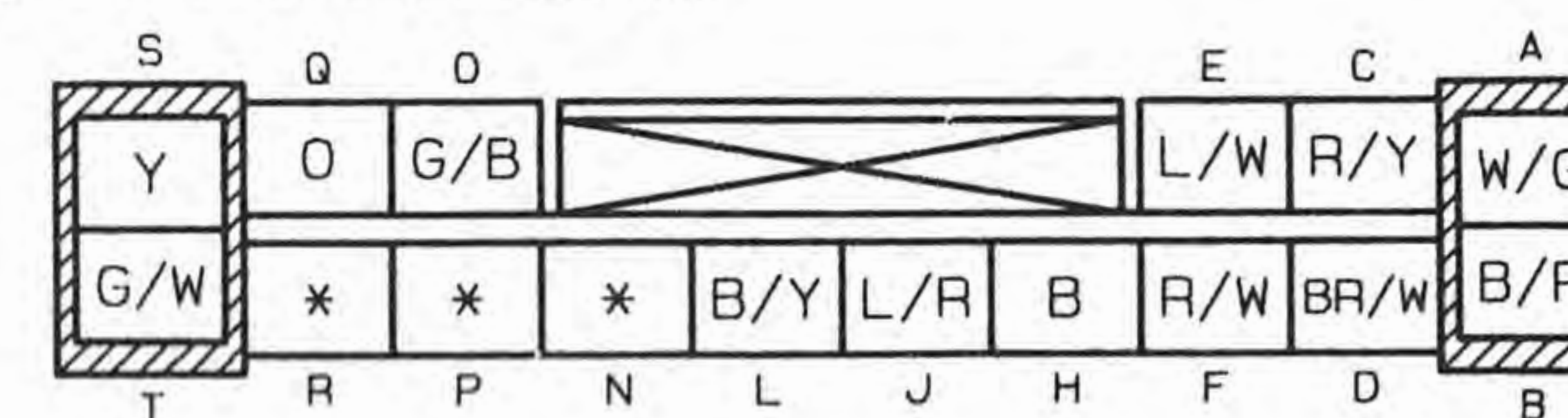

JB-05 INTERIOR LIGHT HARNESS (IN)

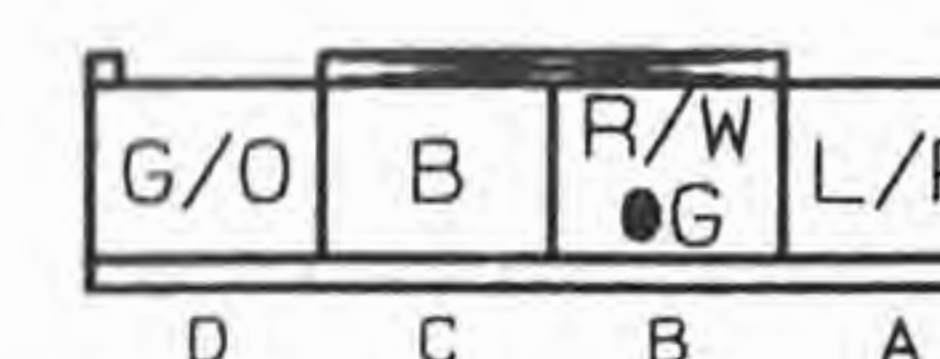

JB-06 JOINT BOX-CENTRAL PROCESSING UNIT

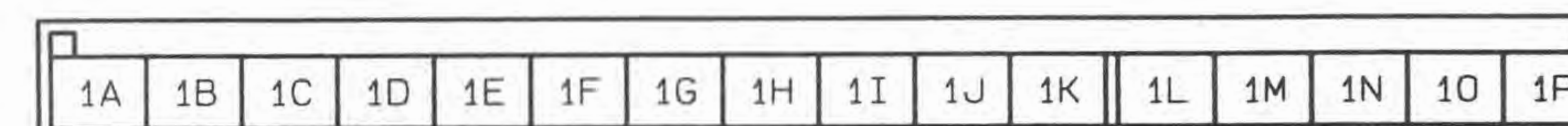



Z-182

■ PARTS INDEX

PI

- A** A/C AMPLIFIER Z-100
- A/C RELAY Z-104,106
- ABS CONTROL MODULE Z-150,152
- ABS HYDRAULIC UNIT Z-150
- ABS RELAY BOX Z-150
- ABS WHEEL-SPEED SENSOR Z-152
- AIR INTAKE ACTUATOR Z-100
- AIR MIX ACTUATOR Z-102
- AIRFLOW MODE ACTUATOR Z-102
- AUDIO UNIT Z-126

- B** BACK-UP LIGHT Z-94,96
- BACK-UP LIGHT SWITCH Z-94,96
- BLOWER MOTOR Z-100
- BLOWER RELAY Z-100
- BRAKE LIGHT Z-98
- BRAKE SWITCH Z-98,156,158
- BUCKLE SWITCH Z-164

- C** CAMSHAFT POSITION SENSOR Z-38
- CENTRAL PROCESSING UNIT Z-138,140,164,166
- CIGARETTE LIGHTER Z-122,124
- CLUTCH SWITCH Z-50,54
- CONDENSER Z-38
- CONDENSER FAN Z-104,106
- CONDENSER FAN HIGH RELAY Z-106
- CONDENSER FAN LOW RELAY Z-106
- COOLANT FAN MOTOR Z-64,66
- COOLANT FAN RELAY Z-64,66
- COURTESY LIGHT Z-118,120
- CRANKSHAFT POSITION SENSOR Z-52
- CRUISE ACTUATOR Z-156,158
- CRUISE CONTROL MAIN SWITCH Z-156,158
- CRUISE CONTROL SWITCH Z-156,158
- CRUISE CONTROL MODULE Z-156,158
- CLOSED THROTTLE POSITION SWITCH Z-50

- D** DATA LINK CONNECTOR Z-168,170
- DATA LINK CONNECTOR(STO) Z-40
- DATA LINK CONNECTOR(STI) Z-42
- DIODE Z-106
- DISTRIBUTOR Z-46,52
- DOOR KEY CYLINDER SWITCH Z-166
- DOOR LOCK LINK SWITCH Z-134,136,138,140
- DOOR LOCK TIMER UNIT Z-134,136,138,140
- DOOR SPEAKER Z-126
- DOOR SWITCH Z-164
- DRIVER-SIDE AIR BAG MODULE Z-162
- DRL CONTROL MODULE Z-86
- DRL RELAY Z-86
- DRL RESISTOR Z-86

- E** EGR VALVE POSITION SENSOR Z-42,48,58
- EGR SOLENOID VALVE(VACUUM) Z-44,50,58
- EGR SOLENOID VALVE(VENT) Z-44,50,58
- ENGINE CONTROL MODULE Z-46,48,50,52,54,56,58
- ENGINE COOLANT TEMPERATURE SENSOR Z-42,48,58

- F** FAIL-SAFE RELAY Z-150
- FAN SWITCH Z-100
- FLASHER UNIT Z-92
- FRONT FOG LIGHT Z-84
- FRONT FOG LIGHT SWITCH Z-84
- FRONT SIDE MARKER LIGHT Z-88,90
- FRONT SPEAKER Z-126
- FRONT TURN LIGHT Z-92
- FRONT-LIFT MOTOR Z-154
- FRONT-LIFT SWITCH Z-154
- FUEL GAUGE Z-68
- FUEL GAUGE SENDER Z-60,62
- FUEL INJECTOR Z-42,48,54
- FUEL LOW INDICATOR CIRCUIT Z-68
- FUEL PUMP Z-60,62
- FUEL PUMP RELAY Z-60,62
- FUEL TANK UNIT Z-60,62

- G** GENERATOR Z-36
- GLOVE COMPARTMENT LIGHT Z-114
- GLOVE COMPARTMENT LIGHT SWITCH Z-114

- H** HAZARD SWITCH Z-92
- HEADLIGHT Z-76,78,80,82
- HEADLIGHT HIGH RELAY Z-86
- HEADLIGHT RELAY Z-76,78,80,82
- HEATED OXYGEN SENSOR Z-38,46,58
- HEATER CONTROL UNIT Z-100,102
- HIGH-MOUNT BRAKE LIGHT Z-98
- HOOD SWITCH Z-166
- HORN Z-98
- HORN RELAY Z-98
- HORN SWITCH Z-98

- I** IDLE AIR CONTROL VALVE Z-44,50,58
- IGNITION COIL Z-38
- IGNITION CONTROL MODULE Z-38
- ILLUMINATION LIGHT**
- ASHTRAY Z-114
- AUDIO Z-114
- CIGARETTE LIGHTER Z-114
- CRUISE CONTROL MAIN SWITCH Z-116
- FRONT FOG LIGHT SWITCH Z-116
- HAZARD SWITCH Z-116
- HEATER CONTROL Z-116
- IGNITION KEY Z-118,120
- REAR WINDOW DEFROSTER SWITCH Z-116
- SELECTOR Z-114
- VANITY MIRROR Z-118
- INBOARD BRAKE LIGHT Z-98
- INBOARD TAILLIGHT Z-88
- INPUT/TURBINE SPEED SENSOR Z-110
- INSTRUMENT CLUSTER Z-68,70,72
- INT RELAY Z-74
- INTAKE AIR TEMPERATURE SENSOR Z-42,48
- INTERIOR LIGHT Z-118,120

- K** KEY REMINDER SWITCH Z-164
- KEYLESS UNIT Z-138,140
- KNOCK SENSOR Z-52

PI

Z WIRING DIAGRAM

PI ■ PARTS INDEX

L	LICENCE PLATE LIGHT	Z-88,90
	LIGHT SWITCH	Z-76,78,80,82
	LIMIT SWITCH	Z-148
	LOCK-LINK SWITCH	Z-166
M	MAGNETIC CLUTCH	Z-104,106
	MAIN RELAY	Z-38,46,52
	MASS AIR FLOW SENSOR	Z-44,46
	MOTOR RELAY	Z-150
N	NEUTRAL SWITCH	Z-50,54
O	O/D OFF SWITCH	Z-40,108
	OIL PRESSURE SWITCH	Z-70
	OIL-LEVEL SENSOR	Z-72
	OSCILLATOR	Z-114
	OUTBOARD BRAKE LIGHT	Z-98
	OUTBOARD TAILLIGHT	Z-88
P	P POSITION SWITCH	Z-112
	PANEL LIGHT CONTROL SWITCH	Z-114
	PARKING BRAKE SWITCH	Z-72
	PARKING LIGHT	Z-88,90
	PASSENGER-SIDE AIR BAG MODULE	Z-98,162
	POWER ANTENNA ASSEMBLY	Z-128
	POWER ANTENNA MOTOR	Z-128
	POWER DOOR LOCK ACTUATOR	Z-134,136,138,140
	POWER OUTSIDE MIRROR	Z-142,144
	POWER OUTSIDE MIRROR SWITCH	Z-142,144
	POWER SEAT	Z-154
	POWER SEAT SWITCH	Z-154
	POWER STEERING PRESSURE SWITCH	Z-40,50,56
	POWER WINDOW MAIN SWITCH ASSEMBLY	Z-130,132
	POWER WINDOW REGULATOR	Z-130,132
	POWER WINDOW SUBSWITCH	Z-130,132
	POWER-CUT SWITCH	Z-130,132
	POWERTRAIN CONTROL MODULE	Z-38,40,42,44
	PRC SOLENOID VALVE	Z-44,50,58
	PURGE SOLENOID VALVE	Z-44,50,58
R	REAR SIDE MARKER LIGHT	Z-88,90
	REAR SPEAKER	Z-126
	REAR TURN LIGHT	Z-92
	REAR WINDOW DEFROSTER	Z-122,124
	REAR WINDOW DEFROSTER RELAY	Z-122,124
	REAR WINDOW DEFROSTER SWITCH	Z-122,124
	REAR-LIFT MOTOR	Z-154
	REAR-LIFT SWITCH	Z-154
	REFRIGERANT PRESSURE SWITCH	Z-100
	RESISTOR	Z-100
S	SAS-UNIT	Z-162
	SHIFT-LOCK ACTUATOR	Z-112
	SLIDE MOTOR	Z-154
	SLIDE SWITCH	Z-154
	SLIDING SUNROOF MOTOR	Z-146,148
	SLIDING SUNROOF RELAY	Z-146,148
	SLIDING SUNROOF SWITCH	Z-146,148
	SOLENOID BODY	Z-44
	SOLENOID VALVE	Z-150
	SOLENOID VALVE(EC-AT) SHIFT SOLENOID A	Z-108
	SHIFT SOLENOID B	Z-108
	3-2 TIMING	Z-108
	SHIFT SOLENOID C	Z-108
	PRESSURE CONTROL	Z-108
	TORQUE CONVERTER CLUTCH	Z-108
	TORQUE CONVERTER CLUTCH CONTROL	Z-108
	SPEEDOMETER	Z-68
	SPOT LIGHTS	Z-118,120
	SPOUT TEST CONNECTOR	Z-38
	STARTER	Z-28,30,32,34
	STARTER INTERLOCK SWITCH	Z-30,34
	STARTER INTERRUPT RELAY	Z-28,30,32,34
	SWING MOTOR	Z-100
T	TACHOMETER	Z-68
	TAILLIGHT	Z-90
	THEFT-DETERRENT CONTROL UNIT	Z-166
	THROTTLE POSITION SENSOR	Z-42,48,58
	TNS RELAY	Z-76,78,80,82
	TRANSAXLE RANGE SWITCH	Z-28,32,38,108
	TRANSAXLE CONTROL MODULE	Z-108,110
	TRANSAXLE FLUID TEMPERATURE SENSOR	Z-108
	TRANSMISSION RANGE SENSOR	Z-28,38
	TRUNK COMPARTMENT LIGHT	Z-122,124
	TRUNK COMPARTMENT LIGHT SWITCH	Z-122,124
	TRUNK KEY CYLINDER SWITCH	Z-166
	TURBINE SHAFT SPEED SENSOR	Z-38
	TURN SWITCH	Z-92
V	VEHICLE SPEEDOMETER SENSOR	Z-68
	VOLUME AIR FLOW SENSOR	Z-58
	VOLTAGE REGULATOR	Z-36
	VRIS SOLENOID VALVE	Z-58
W	WATER TEMPERATURE GAUGE	Z-68
	WATER TEMPERATURE SENSOR UNIT	Z-68
	WINDSHIELD WASHER MOTOR	Z-74
	WINDSHIELD WASHER SWITCH	Z-74
	WINDSHIELD WIPER MOTOR	Z-74
	WINDSHIELD WIPER SWITCH	Z-74